

HAZ METAL FIXING SYSTEMS

Your Fixing Systems Specialist

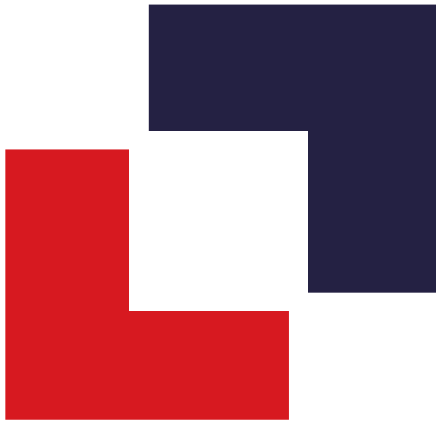

Framing Systems
Technical Product Catalogue
HAZ-FS-EN/04.20

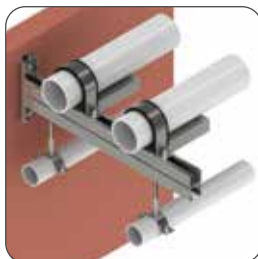



Abu Dhabi Financial Centre, Abu Dhabi



Contents

Company Profile	1-2
HMP Framing systems introduction	3-4
HMP Framing systems product range	5-6
HMP Channels technical details	7-12
HMP Channels technical details summary	13-14
HMC Brackets introduction & technical details	15-16
HCC Channel connections	17-18
HTB Lock nuts & HMLN Lock details	19-20
HMCI Concrete inserts details	21-22
HPCL Pipe clamps introduction	23
HPCL Pipe clamps technical details	24-26
Framing systems accessories	27-28
HMP Framing systems application examples	29-30

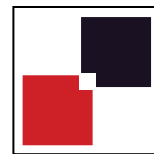

HAZ METAL
FIXING SYSTEMS

Your Fixing Systems Specialist



Company Profile

Introduction

HAZ Metal A.S. is located in Iskenderun, in the southern part of Turkey, based in their own property of 17.000 square meters .

The company provides services in the design and production of fixing systems for facade cladding, framing channel systems, brick support systems, cast-in channels and a variety of products used in construction.

The company's mission statement is to assist and advise its clients in choosing the most suitable fixing systems for their requirements and to provide them with quality production and supply with timely deliveries.

The innovative design and production techniques offer practical and economical solutions to solve every possible problem within the scope of fixing applications in construction. As a manufacturer of fixing systems to major projects around the world, HAZ Metal has proven its quality and reliability to its clients.

The company enjoys serving the sector and works hard to constantly improve and develop its services. HAZ Metal is dedicated to achieving the highest level of customer satisfaction and is always in constant contact with its clients in order to offer the services required in design and production.

Channel production

The production of channels has been done in HAZ Metal since the year 1999.

Throughout the years of production, techniques and methods have been improved achieving higher quality and productivity. HAZ Metal today implements modern technology in the production of channels.

The factory channel production unit is equipped with a coil slitting machine, channel roll formers and press feeds for the drilling of the channels. There is also an in house electro galvanising pool where 12 micro thick zinc coating on mild steel is made.

The presence of a work shop with the capability of preparing and maintaining the required rolls and tooling, provides flexible production. The urgent preparations, maintenance, revision and adjustment of machines and tooling are made without interrupting the production process saving time and cost.

The production is strictly controlled with periodic in house testing for both raw materials and finished products, in order to maintain the performance of HAZ products and to fulfil the safety requirements for use in the construction industry.



Production Capacity

The HAZ Metal production unit for channels is equipped with machinery to produce more than 500 tons of channels per month. The production of all items is made in the company.

Channels are produced by rolling in roll forming machines and by bending using press break machines. Channels can be produced up to 6 metre lengths. Apart from standard products, the production of special items is also made to suit various application requirements.

Technical Know-How

HAZ Metal's technical staff, each with more than 10 years experience, has an outstanding technical knowledge in the field of stainless steel production.

The maintenance of the machines and the preparation of moulds for production are done in the company's workshop. This ensure higher efficiency and productivity in production, increasing quality of services with competitive prices.

Quality Standards

HAZ Metal implements EN and ASTM standards in the production of channels. Production is strictly controlled within the tolerances of these standards.

All products are produced by its personnel, applying the latest production methods with advanced machinery. The quality control team, under the supervision of a mechanical engineer, is selected from long serving and experienced foremen.

Production is checked during each production step and is compared with production drawings and specifications. The company is strictly bound to the concept of ISO 9001:2008 and "Total Quality Management" system. A quality assurance system is set up and is running to cover the control of each process in manufacturing. The control checks are documented and are recorded.

The application of this management system is maintained and is a part of day to day operations.



HMP Framing Channels - Introduction

HMP Framing systems with channels and various accessories are used to build steel constructions for the installation of various types of sub structures. Efficient modular support structures are built quickly and easily. Flexible and low cost application is achieved.

Framing systems consist of cold formed steel and stainless steel channels which are supplied with suitable T bolts and lock nuts to build secondary structures for various types of applications in construction. Attachments of any kind of elements are achieved with T bolts or lock nuts. Bolting is made freely at the desired position along the length of the channels. Some of the areas of use consist of pipe and duct installation, machinery set ups, mechanical and electrical installations. The use of framing systems eliminates drilling and welding on site therefore resulting in safe and quick commencement of construction works.

Channels are supplied either plain or with perforated slotted or round drilled holes. Galvanized steel and stainless steel is available.



HMPB C Channels



HMPC C Channels



HMPD C Channels



HMPA U Channels



HMPL L Channels

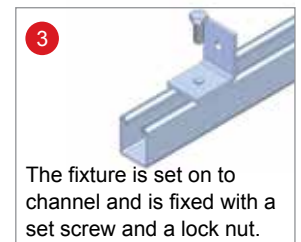
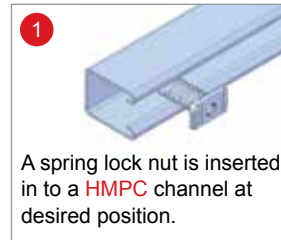

- a. **HMP**S Channel
- b. **HMLN** Lock nut
- c. **HCC** Channel connection
- d. **DIN 933** Set screw

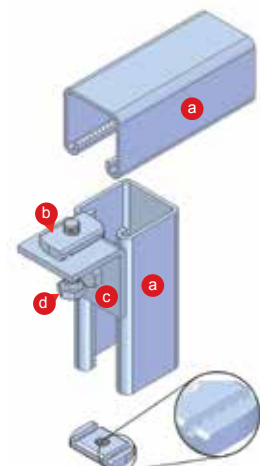

HMP Framing Channels - Introduction



Advantages:

- Fast and Secure fixing.
- No time consuming welding and hole setting.
- No use of welding and drilling equipment.
- Adjustable and nonslip point fixing.
- Cost effective and flexible.
- Quick and easy fixing.
- Can be re-used.
- No special tools.

HAZ Metal manufactures cold rolled channels up to 6 metres in length in stainless steel and hot dip galvanised steel. Various accessories such as brackets, connection parts, lock nuts are available to complete the framing systems.

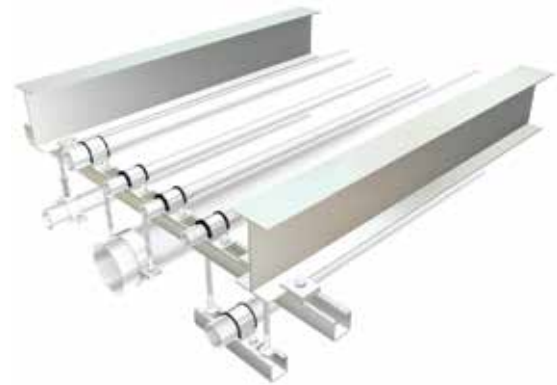

Framing systems are assembled without the need of welding. Suitable connection parts, lock nuts and DIN 933 set screws are used together to assemble the channels together formulating a steel construction. Various formations can be made to withstand the loads required.

Framing systems are widely used for the installation of pipes. Channels are fixed on to steel beams with connection elements. Fixing of pipe clamps with threaded rods are quickly and easily made on to the channels using lock nuts. The adjustability of this system is ideal for economic installation.



Mechanical, plumbing and electrical utilities are installed using framing systems. Channel systems and its accessories provide easy and efficient solutions to meet any project's requirement. The flexibility of the framing systems offers endless formation to suit any type of application.

The combination of channels, brackets and channel connections allows the building of frames that are self standing. The frame work can be fixed on to the concrete ground. The modular frame works provide efficient and reliable solutions for various applications such as pipeline installation, machinery assembly and electrical fittings.

HMP Framing Systems - Product Range

HMPB C Channels

Channels with 90 degree inclined lips used for loads up to 7.0 kN. Channels are available plain and slotted in maximum 6 metre length. Available in stainless steel grade 1.4301 & 1.4401 and hot dip & electro galvanized mild steel.

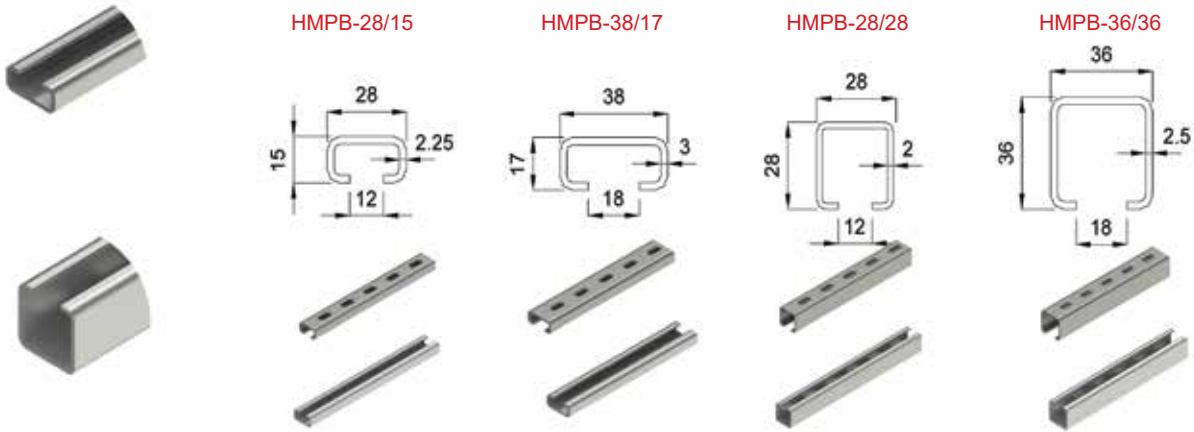

HMPC & HMPS C Channels

Channels with 180 degree inclined lips used for loads up to 15.0 kN. HMPC channels are available plain and slotted. HMPS toothed channels are available in plain and back to back versions. Channels are produced in maximum 6 metre lengths. Available in stainless steel grade 1.4301 & 1.4401 and hot dip & electro galvanized mild steel.

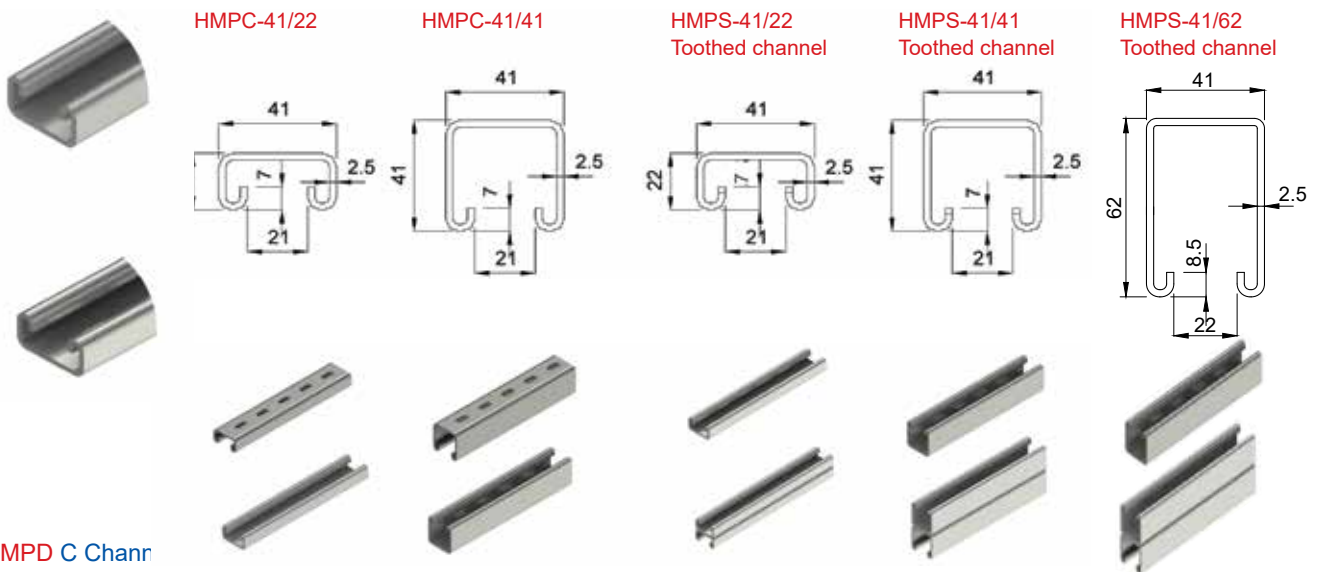

HMPD C Chanr

Channels with 135 degree inclined lips used for loads up to 25 kN. Channels are available plain and slotted in maximum 6 metre lengths. Available in stainless steel grade 1.4301 & 1.4401 and hot dip & electro galvanized mild steel.

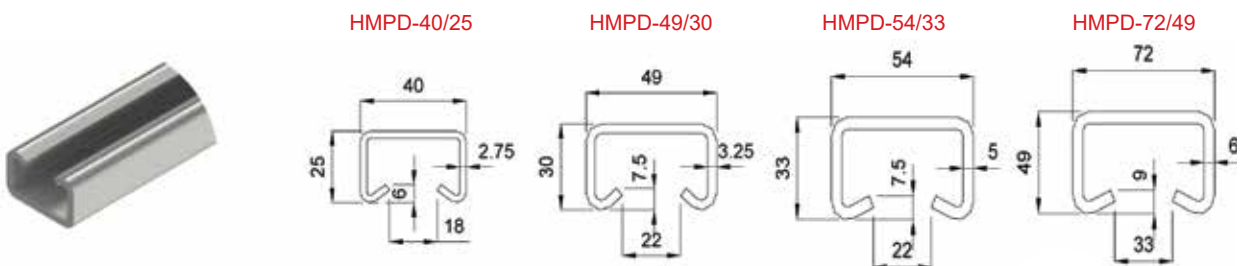

HMP Framing Systems - Product Range

HMPA U Channel & HMPL L Channel

Channels are available in drilled or slotted hole versions in maximum 6 metre lengths. Allowable loads are available for submittal upon the request of the project.

Available in stainless steel grade 1.4301 & 1.4401 and hot dip & electro galvanized mild steel.

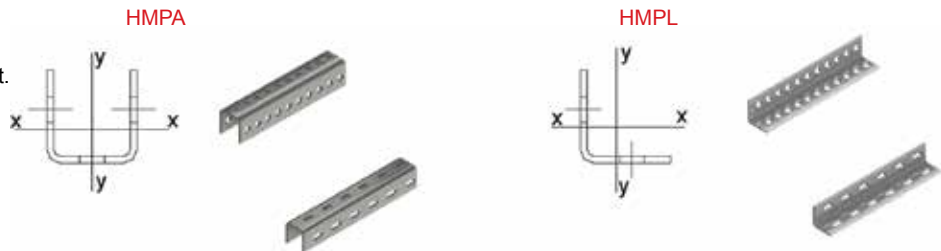

HMC Brackets

Brackets are available in a variety of types and sets for the assembly of framing systems on to any kind of substructures. Allowable loads are available for submittal upon the request of the project.

Available in stainless steel grade 1.4301 & 1.4401 and hot dip & electro galvanized mild steel.

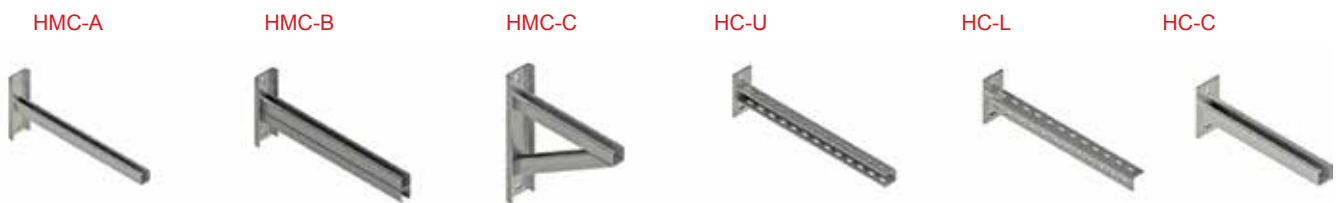

HCC Channel Connections

Channel connections are available in a variety of types to be used with HMPB 36/36 and HMPC 41/41 C channels.

Available in stainless steel grade 1.4301 & 1.4401 and hot dip & electro galvanized mild steel.

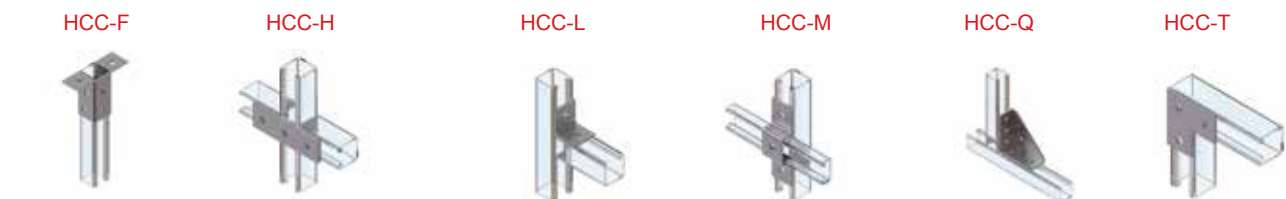

Accessories

Various types of accessories are available for the connection of the framing system elements. Types and sizes are determined according to the framing system used and the loads which are required. Stainless steel and galvanized materials are available.



HMPB C Channels - Product Details

HMPB-28/15 C Channel	Technical Details									
	Product	Cross Section	Moment of inertia		Section Modulus		Point loading kN	Bending cap.		
			I_x cm ⁴	I_y cm ⁴	W_x cm ³	W_y cm ³		Span cm	0.5 (kN)	1 (kN)

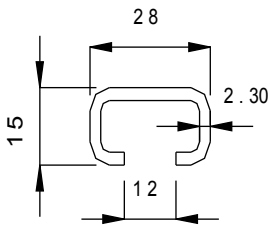

Slotted Channel Type

HMPB-S-28/15	1.16	0.31	1.35	0.39	0.96	3.9/7	0.69	0.17	0.08
---------------------	------	------	------	------	------	-------	------	------	------



Channel with $\varnothing 9 \times 25$ mm slotted holes.

Plain Channel Type

HMPB-P-28/15	1.36	0.37	1.37	0.42	0.98	3.9/9	0.81	0.21	0.09
---------------------	------	------	------	------	------	-------	------	------	------



* Plain Channels

* Standard lengths are 3 or 6 meters.

* Available in Stainless steel grade 1.4301 & 1.4401 and hot dip and electro galvanized mild steel.

HMPB-38/17 C Channel	Technical Details									
	Product	Cross Section	Moment of inertia		Section Modulus		Point loading kN	Bending cap.		
			I_x cm ⁴	I_y cm ⁴	W_x cm ³	W_y cm ³		Span cm	0.5 (kN)	1 (kN)

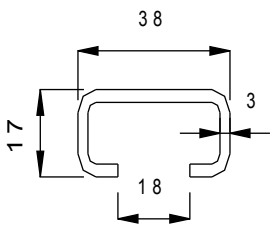

Slotted Channel Type

HMPB-S-38/17	1.76	0.60	3.93	0.68	2.07	4.8/9	1.28	0.36	0.18
---------------------	------	------	------	------	------	-------	------	------	------

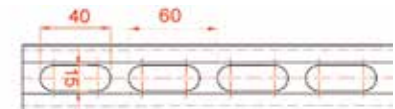

Channel with $\varnothing 15 \times 40$ mm slotted holes.

Plain Channel Type

HMPB-P-38/17	2.22	0.76	4.02	0.75	2.12	4.8/11	1.4	0.40	0.19
---------------------	------	------	------	------	------	--------	-----	------	------





* Plain Channels

* Standard lengths are 3 or 6 meters.

* Available in Stainless steel grade 1.4301 & 1.4401 and hot dip and electro galvanized mild steel.

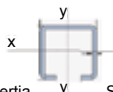
HMPB C Channels - Product Details

HMPB-28/28 C Channel	Technical Details									
	Product	Cross Section					 Point loading	 Bending cap.		
			A cm ²	I _x cm ⁴	I _y cm ⁴	W _x cm ³		W _y cm ³	kN	Span cm

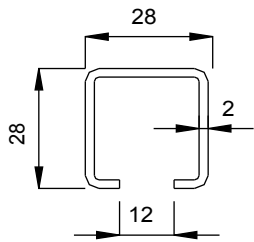

Slotted Channel Type

HMPB-S-28/28	1.48	1.32	2.10	0.95	1.50	3.00/25	1.50	0.70	0.30
---------------------	------	------	------	------	------	---------	------	------	------

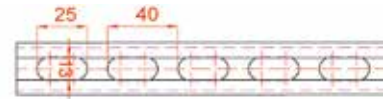

Channel with $\varnothing 13 \times 25$ mm slotted holes.

Plain Channel Type



HMPB-P-28/28	1.73	1.70	2.13	1.08	1.52	3.00/31	1.90	0.90	0.40
---------------------	------	------	------	------	------	---------	------	------	------



* Plain Channels

* Standard lengths are 3 or 6 meters.

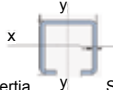
* Available in Stainless steel grade 1.4301 & 1.4401 and hot dip and electro galvanized mild steel.

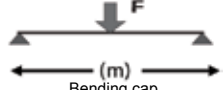
HMPB-36/36 C Channel	Technical Details									
	Product	Cross Section					 Point loading	 Bending cap.		
			A cm ²	I _x cm ⁴	I _y cm ⁴	W _x cm ³		W _y cm ³	kN	Span cm

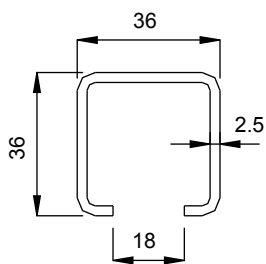

Slotted Channel Type

HMPB-S-36/36	2.39	3.55	5.68	1.92	3.15	4.40/36	3.30	1.60	0.80
---------------------	------	------	------	------	------	---------	------	------	------

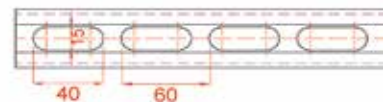

Channel with $\varnothing 15 \times 40$ mm slotted holes.

Plain Channel Type

HMPB-P-36/36	2.76	4.40	5.75	2.12	3.19	4.40/44	3.90	1.90	1.00
---------------------	------	------	------	------	------	---------	------	------	------



* Plain Channels

* Standard lengths are 3 or 6 meters.

* Available in Stainless steel grade 1.4301 & 1.4401 and hot dip and electro galvanized mild steel.

HMPC C Channels - Product Details

HMPC-41/22 C Channel	Technical Details									
	Product	Cross Section	Moment of inertia		Section Modulus		Point loading kN Span cm	Bending cap.		
			$I_x \text{ cm}^4$	$I_y \text{ cm}^4$	$W_x \text{ cm}^3$	$W_y \text{ cm}^3$		0.5 (kN)	1 (kN)	1.5 (kN)

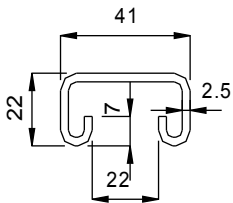

Slotted Channel Type

HMPC-S-41/22	1.99	1.15	5.34	0.89	2.60	5.6/12	1.50	0.50	0.20
---------------------	------	------	------	------	------	--------	------	------	------

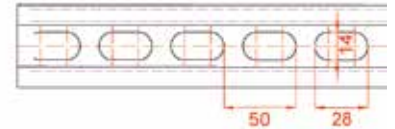

Channel with $\phi 14 \times 28$ mm slotted holes.

Plain Channel Type

HMPC-P-41/22	2.36	1.39	5.40	0.99	2.63	5.6/15	1.80	0.60	0.20
---------------------	------	------	------	------	------	--------	------	------	------



* Plain Channels

* Standard lengths are 3 or 6 meters.

* Available in Stainless steel grade 1.4301 & 1.4401 and hot dip and electro galvanized mild steel.

HMPC-41/41 C Channel	Technical Details									
	Product	Cross Section	Moment of inertia		Section Modulus		Point loading kN Span cm	Bending cap.		
			$I_x \text{ cm}^4$	$I_y \text{ cm}^4$	$W_x \text{ cm}^3$	$W_y \text{ cm}^3$		0.5 (kN)	1 (kN)	1.5 (kN)

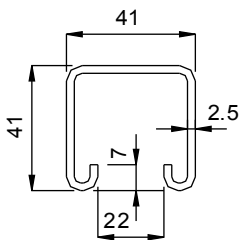

Slotted Channel Type

HMPC-S-41/41	2.96	5.90	8.88	2.82	4.33	5.6/42	4.70	2.30	1.14
---------------------	------	------	------	------	------	--------	------	------	------

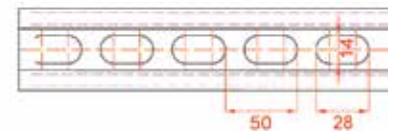

Channel with $\phi 14 \times 28$ mm slotted holes.

Plain Channel Type

HMPC-P-41/41	3.31	7.00	8.93	3.04	4.36	5.6/58	5.4	2.7	1.7
---------------------	------	------	------	------	------	--------	-----	-----	-----





* Plain Channels

* Standard lengths are 3 or 6 meters.

* Available in Stainless steel grade 1.4301 & 1.4401 and hot dip and electro galvanized mild steel.

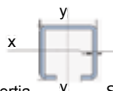
HMPS C Channels - Product Details

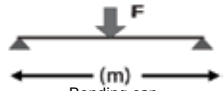
HMPS-41/22 C Channel	Technical Details										
	Product	Cross Section					 Point loading	 Bending cap.	(m)		
			A cm ²	I _x cm ⁴	I _y cm ⁴	W _x cm ³			W _y cm ³	kN	Span cm

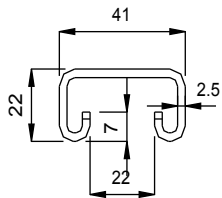

Slotted Channel Type

HMPS-S-41/22	1.99	1.15	5.34	0.89	2.60	5.6/12	1.50	0.50	0.20
---------------------	------	------	------	------	------	--------	------	------	------

Plain Channel Type

HMPS-P-41/22	2.36	1.39	5.40	0.99	2.63	5.6/14	1.70	0.60	0.20
---------------------	------	------	------	------	------	--------	------	------	------

* Plain channel



* Slotted channel

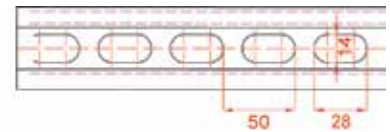

Channel with $\varnothing 14 \times 28$ mm slotted holes.

Back to back Channel Type

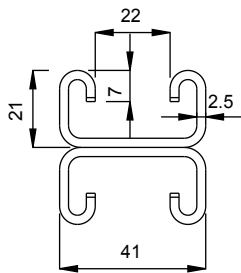

HMPS-B-41/22	4.62	6.43	10.67	2.62	5.20	5.6/42	4.50	2.20	1.30
---------------------	------	------	-------	------	------	--------	------	------	------



* Back to back channel

* Standard lengths are 3 or 6 meters.

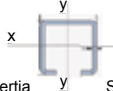
* Available in Stainless steel grade 1.4301 & 1.4401 and hot dip and electro galvanized mild steel.

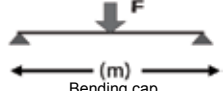
HMPS-41/41 C Channel	Technical Details										
	Product	Cross Section					 Point loading	 Bending cap.	(m)		
			A cm ²	I _x cm ⁴	I _y cm ⁴	W _x cm ³			W _y cm ³	kN	Span cm

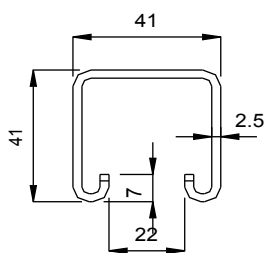

Slotted Channel Type

HMPS-S-41/41	2.96	5.90	8.88	2.82	4.33	5.6/41	4.70	2.30	1.40
---------------------	------	------	------	------	------	--------	------	------	------

Plain Channel Type

HMPS-P-41/41	3.25	6.85	8.85	2.90	4.32	5.6/47	5.30	2.60	1.60
---------------------	------	------	------	------	------	--------	------	------	------

* Plain channel



* Slotted channel

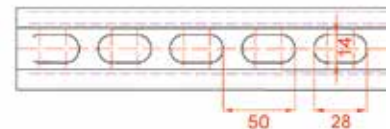

Channel with $\varnothing 14 \times 28$ mm slotted holes.

Back to back Channel Type

HMPS-B-41/41	6.51	34.31	17.72	8.21	8.64	5.6/130	14.90	7.40	4.90
---------------------	------	-------	-------	------	------	---------	-------	------	------

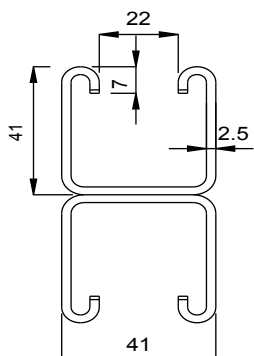



* Back to back channel

* Standard lengths are 3 or 6 meters.

* Available in Stainless steel grade 1.4301 & 1.4401 and hot dip and electro galvanized mild steel.

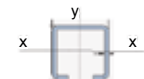
HMPD C Channels - Product Details

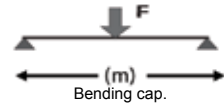
HMPD-40/25 C Channel	Technical Details										
	Product	Cross Section					 Point loading	 Bending cap.			
			A cm ²	I _x cm ⁴	I _y cm ⁴	W _x cm ³			W _y cm ³	kN	Span cm

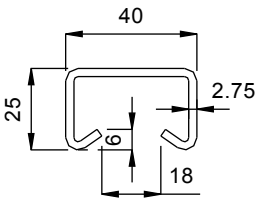

Plain Channel Type



HMPD-P-40/25	2.66	2.02	6.08	1.37	3.04	3.80/33	2.40	1.00	0.40
---------------------	------	------	------	------	------	---------	------	------	------



* Plain Channels

* Standard lengths are 3 or 6 meters.

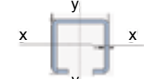
* Available in Stainless steel grade 1.4301 & 1.4401 and hot dip and electro galvanized mild steel.

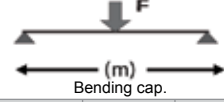
HMPD-49/30 C Channel	Technical Details										
	Product	Cross Section					 Point loading	 Bending cap.			
			A cm ²	I _x cm ⁴	I _y cm ⁴	W _x cm ³			W _y cm ³	kN	Span cm

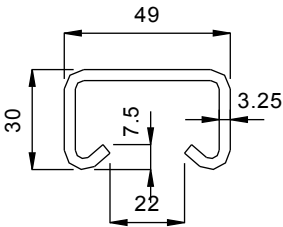

Plain Channel Type



HMPD-P-49/30	3.85	4.27	13.10	2.50	5.35	4.90/46	4.50	2.20	1.00
---------------------	------	------	-------	------	------	---------	------	------	------



* Plain Channels

* Standard lengths are 3 or 6 meters.

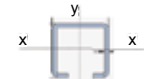
* Available in Stainless steel grade 1.4301 & 1.4401 and hot dip and electro galvanized mild steel.

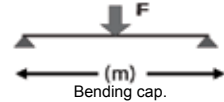
HMPD-54/33 C Channel	Technical Details										
	Product	Cross Section					 Point loading	 Bending cap.			
			A cm ²	I _x cm ⁴	I _y cm ⁴	W _x cm ³			W _y cm ³	kN	Span cm

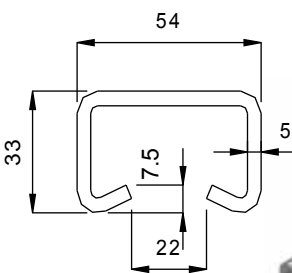

Plain Channel Type

HMPD-P-54/33	6.12	7.74	23.66	3.98	8.76	5.00/52	7.25	3.60	1.80
---------------------	------	------	-------	------	------	---------	------	------	------



* Plain Channels

* Standard lengths are 3 or 6 meters.

* Available in Stainless steel grade 1.4301 & 1.4401 and hot dip and electro galvanized mild steel.

HMPA & HMPL Channels - Product Details

HMPA U Channel	Product Code	Technical Details								
		Dimensions			X-X Axis			Y-Y Axis		
		Thickness T (mm)	Width W (mm)	Height H (mm)	IXX (cm ⁴)	ZX (cm ³)	X (mm)	IYY (cm ⁴)	ZY (cm ³)	Y (mm)

Plain Channel Type

HMPA-2,54040	2.5	40.00	40.00	3.63	1.40	20	5.42	4.31	14.06
HMPA-34040	3	40.00	40.00	4.22	1.63	20	6.30	3.15	14.07
HMPA-44040	4	40.00	40.00	5.15	2.01	20	7.67	3.84	14.37
HMPA-45050	4	50.00	50.00	11.57	3.61	25	17.50	7.00	17.94
HMPA-55050	5	50.00	50.00	13.66	4.30	25	20.53	8.21	18.20

* The values given above have been calculated for Ø13mm hole on channels.

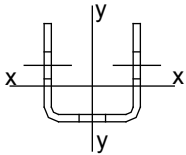

* Channel with ø9, 11 or 13 mm drilled holes.

* Spacing is 20 mm at hole centers.

* Standard lengths are 3 or 6 meters.

* Available in Stainless steel grade 1.4301 & 1.4401 and hot dip and electro galvanized mild steel.

* Channel with ø9x30, 11x40 or 14x28 slotted holes.

* Spacing is 50 mm at hole centers.

HMPL Channel	Product Code	Technical Details								
		Dimensions			X-X Axis			Y-Y Axis		
		Thickness T (mm)	Width W (mm)	Height H (mm)	IXX (cm ⁴)	ZX (cm ³)	X (mm)	IYY (cm ⁴)	ZY (cm ³)	Y (mm)

Plain Channel Type

HMPL-2,54040	2.5	40.00	40.00	2.23	0.76	20	2.23	0.76	10.63
HMPL-34040	3	40.00	40.00	2.58	0.88	20	2.58	0.88	10.74
HMPL-44040	4	40.00	40.00	3.18	1.09	20	3.18	1.09	10.94
HMPL-45050	4	50.00	50.00	7.17	1.97	25	7.17	1.97	13.65
HMPL-55050	5	50.00	50.00	8.50	2.35	25	8.50	2.35	13.90

* The values given above have been calculated for Ø13mm hole on channels.

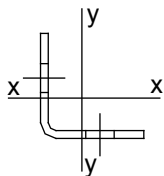

* Channel with ø9, 11 or 13 mm drilled holes.

* Spacing is 20 mm at hole centers.



* Standard lengths are 3 or 6 meters.

* Available in Stainless steel grade 1.4301 & 1.4401 and hot dip and electro galvanized mild steel.

* Channel with ø9x30, 11x40 or 14x28 slotted holes.

* Spacing is 50 mm at hole centers.

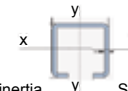
HMP Channels - Product Details Summary

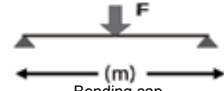
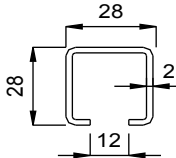
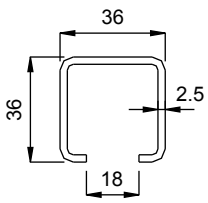
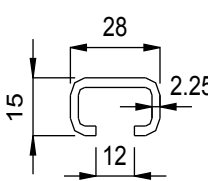
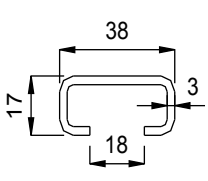
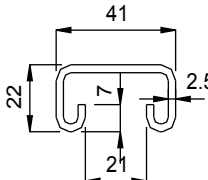
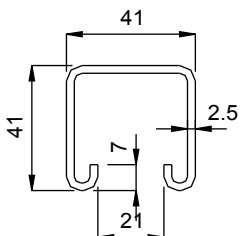
Channel Type	Technical Details									
	Product	Cross Section					 Point loading	 Bending cap.		
			A cm ²	I _x cm ⁴	I _y cm ⁴	W _x cm ³		W _y cm ³	kN Span cm	0.5 (kN)
	HMPB-S-28/28	1.48	1.32	2.10	0.95	1.50	3.50	1.50	0.70	0.30
	HMPB-P-28/28	1.73	1.70	2.13	1.08	1.52	3.00	1.90	0.90	0.40
	HMPB-S-36/36	2.39	3.55	5.68	1.92	3.15	4.40	3.30	1.60	0.80
	HMPB-P-36/36	2.76	4.40	5.75	2.12	3.19	4.40	3.90	1.90	1.00
	HMPB-S-28/15	1.16	0.31	1.35	0.39	0.96	3.90	0.69	0.17	0.08
	HMPB-P-28/15	1.36	0.37	1.37	0.42	0.98	3.90	0.81	0.21	0.09
	HMPB-S-38/17	1.76	0.60	3.93	0.68	2.07	4.80	1.28	0.36	0.18
	HMPB-P-38/17	2.22	0.76	4.02	0.75	2.12	4.80	1.40	0.40	0.19
	HMPC-S-41/22	1.99	1.15	5.34	0.89	2.60	5.60	1.50	0.50	0.20
	HMPC-P-41/22	2.36	1.39	5.40	0.99	2.63	5.60	1.80	0.60	0.20
	HMPC-S-41/41	2.96	5.90	8.88	2.82	4.33	5.60	4.70	2.30	1.40
	HMPC-P-41/41	3.31	7.00	8.93	3.04	4.36	5.60	5.40	2.70	1.70

HMP Channels - Product Details Summary

Channel Type	Product	Cross Section	Technical Details								
			Moment of inertia		Section Modulus		Point loading kN	Span cm	Bending cap.		
			I_x cm ⁴	I_y cm ⁴	W_x cm ³	W_y cm ³			0.5 (kN)	1 (kN)	1.5 (kN)

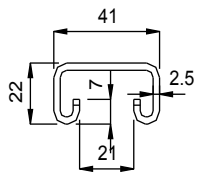

HMPSP-P-41/22	2.30	1.37	5.33	0.97	2.60	5.60	1.70	0.60	0.20
HMPSP-B-41/22	4.62	6.43	10.67	2.62	5.20	5.60	4.50	2.20	1.30

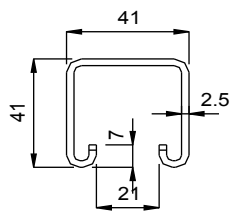

HMPSP-P-41/41	3.25	6.85	8.85	2.90	4.32	5.60	5.30	2.60	1.60
HMPSP-B-41/41	6.51	34.31	17.72	8.21	8.64	5.60	14.90	7.40	4.90

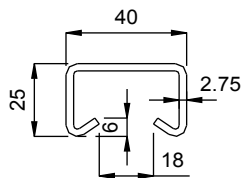

HMPDP-P-40/25	2.66	2.02	6.08	1.37	3.04	8.00	2.40	1.20	0.60
----------------------	------	------	------	------	------	------	------	------	------

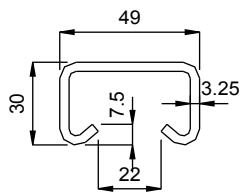

HMPDP-P-49/30	3.85	4.27	13.10	2.50	5.35	12.00	4.50	2.20	1.40
----------------------	------	------	-------	------	------	-------	------	------	------

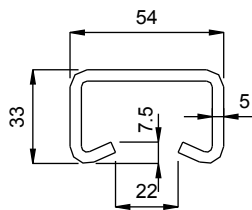

HMPDP-P-54/33	6.12	7.74	23.66	3.98	8.76	25.00	7.10	3.60	2.40
----------------------	------	------	-------	------	------	-------	------	------	------

Channel Type	Product Code	Technical Details								
		Dimensions			X-X Axis			Y-Y Axis		
		Thickness T (mm)	Width W (mm)	Height H (mm)	I_{XX} (cm ⁴)	Z_X (cm ³)	X (mm)	I_{YY} (cm ⁴)	Z_Y (cm ³)	Y (mm)

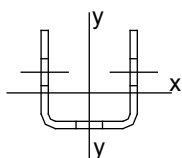

HMPA-2,54040	2.5	40.00	40.00	3.63	1.40	20	5.42	4.31	14.06
HMPA-34040	3	40.00	40.00	4.22	1.63	20	6.30	3.15	14.07
HMPA-44040	4	40.00	40.00	5.15	2.01	20	7.67	3.84	14.37
HMPA-45050	4	50.00	50.00	11.57	3.61	25	17.50	7.00	17.94
HMPA-55050	5	50.00	50.00	13.66	4.30	25	20.53	8.21	18.20

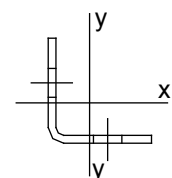

HMPL-2,53030	2.5	30.00	30.00	2.23	0.76	20	2.23	0.76	10.63
HMPL-34040	3	40.00	40.00	2.58	0.88	20	2.58	0.88	10.74
HMPL-44040	4	40.00	40.00	3.18	1.09	20	3.18	1.09	10.94
HMPL-45050	4	50.00	50.00	7.17	1.97	25	7.17	1.97	13.65
HMPL-55050	5	50.00	50.00	8.50	2.35	25	8.50	2.35	13.90

HMC Cantiliver Brackets - Introduction

HMC Cantiliver brackets are used to install framing systems on to walls. The brackets are installed on to concrete walls with expansion bolts and also with T head bolts into cast in channels. The brackets act as load transferring units where various types of installation can be made.

Each item has a certain load capacity and can be applied for different offset distances. High quality welding is made in order to guarantee load bearing capacity.

Materials available are stainless steel type 1.4301 & 1.4401 and galvanized mild steel.

Advantages

- Fast and Secure fixing.
- Adjustable and easy fixing.
- Cost effective and flexible.
- Can be re-used.
- Compatible with HMP framing.
- Assembly with T bolts or lock nuts.



- a. Concrete wall
- b. HMPR-S toothed Cast-in channel
- c. HTB-41 T head bolt
- d. HMC Bracket

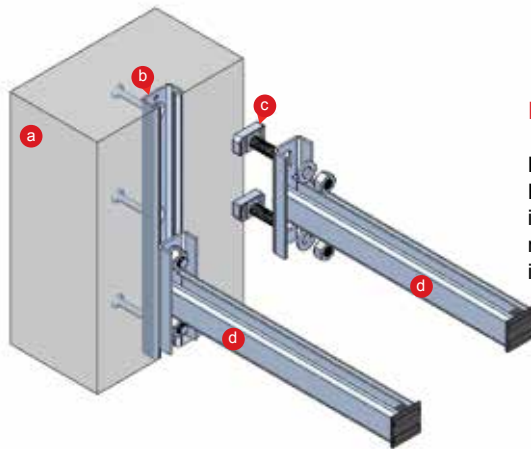

In Combination With HMP and HMPR Channels

HMC Brackets provide full adjustability when used with HMP framing and HMPR cast in channels. When installing on to cast in channels with lock nuts or T bolts, no damage occurs to the concrete walls. Easy and quick installation is provided.

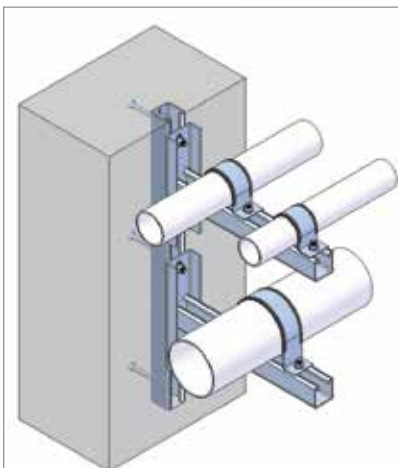

Installation of pipes made easy when using HMC brackets fixed on to HMPR cast in channels.

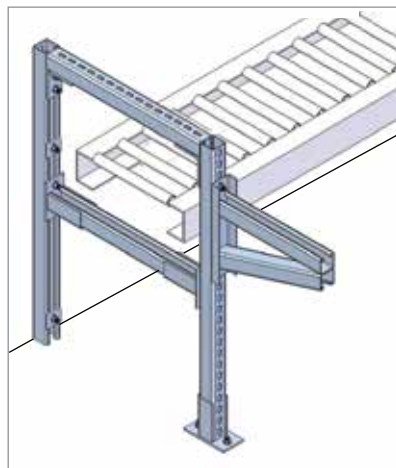

Mounting of assembly lines using framing and brackets.

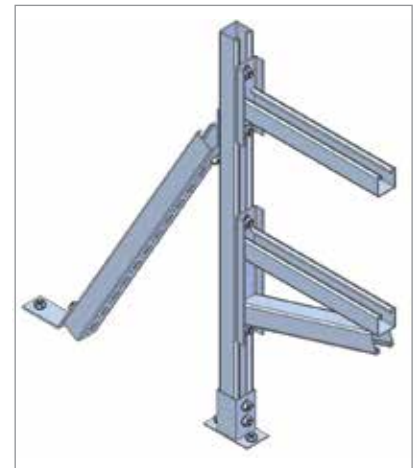

Self supporting structures mounted with framing channels and HMC brackets.

HMC Cantaliver Brackets - Product Details

Product

Product Code		
Type	Height	Length

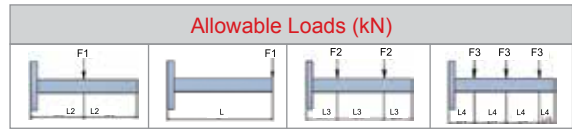

HMC-A 41 Bracket



HMC-A 41	180	175
		325
		475

5.35	2.65	2.65	1.75
2.65	1.30	1.30	0.85
1.75	0.85	0.85	0.55

HMC-B 41 Bracket



HMC-B 41	180	325
		475
		625

5.60	2.80	2.80	1.85
3.70	1.85	1.85	1.20
2.80	1.40	1.40	0.90

HMC-C 41 Bracket



HMC-C 41	270	325
	330	475
	380	625
	430	775

7.50	4.90	4.80	3.40
5.00	4.75	3.70	2.45
3.50	3.50	2.75	1.85
2.65	2.65	2.05	1.40

HMC-A 36 Bracket



HMC-A 36	180	300
		400
		500
		600

2.00	1.00	1.00	0.70
1.50	0.75	0.75	0.50
1.20	0.60	0.60	0.40
1.00	0.50	0.50	0.33

HMC-B 36 Bracket



HMC-B 36	180	300
		400
		500
		600

4.20	2.00	2.00	1.50
3.00	1.60	1.60	1.00
2.50	1.30	1.30	0.80
2.10	1.10	1.10	0.70

HMC-C 36 Bracket



HMC-C 36	225	300
	280	400
	310	500
	340	600
	370	700

5.00	4.20	4.00	2.65
4.15	4.10	3.15	2.10
3.15	3.05	2.50	1.65
2.55	3.35	2.00	1.30
2.10	3.15	1.65	1.10

HC Brackets

Brackets for light weight installations are available in stainless steel and galvanized steel.

HC-C Bracket



HC-U Bracket



HC-L Bracket



HCC Channel Connections - Introduction

HCC channel connections are used to mount framing systems together. Lock nuts and set screws are used to build support structures for various applications.

The HCC channel connections are available in three series to be used with channels HMPB & HMPC. The series are 28 for channel type 28/15 and 28/28; 36 for channel type 36/36; and series 41 for channel type 41/41 and 41/21.

Material Available are stainless steel type 1.4301 & 1.4401 and galvanized mild steel.

Advantages

- Fast and secure fixing.
- Adjustable and easy fixing.
- Cost effective and flexible.
- Can be re-used.
- Compatible with HMP framing.
- Assembly with T bolts or lock nuts.



In Combination With HMP and HMPR Channels

HCC channel connections are used in combination with the HMP and HMPR channels to build structures to be used in a wide range of construction applications. HCC channel connections and HMP channels and HMPR cast in channels are connected to each other with HTB T bolts or HMLN lock nuts.

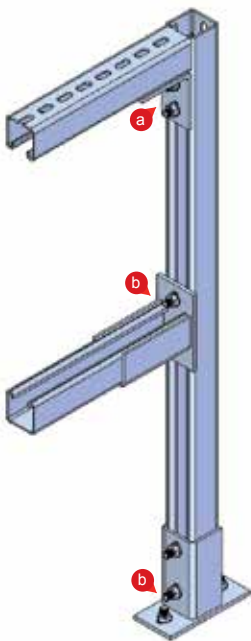

a. HCC-I Channel Connection

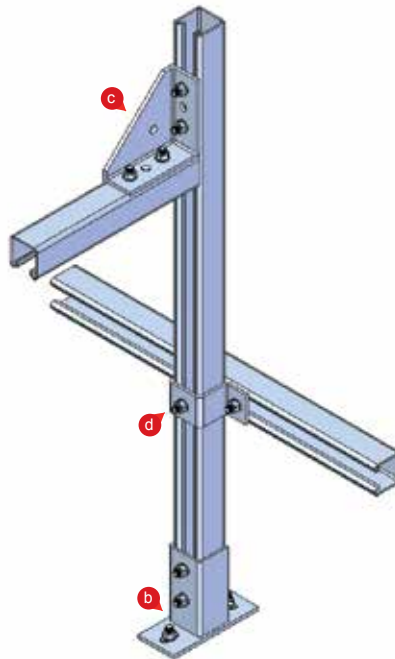

c. HCC-O Channel Connection

b. HCC-B Channel Connection

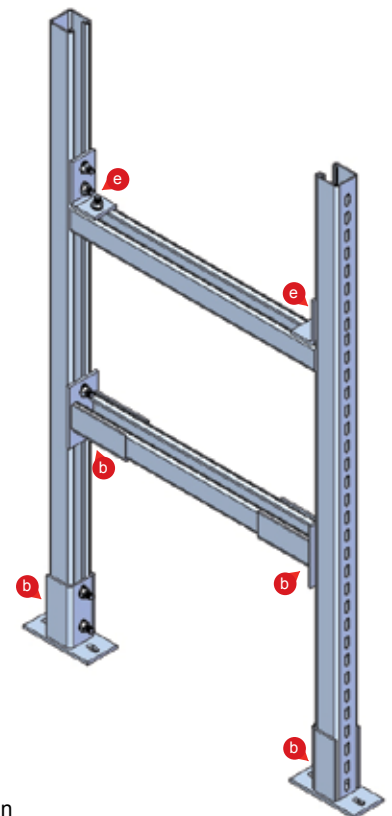

d. HCC-K Channel Connection

e. HCC-H Channel Connection

HCC Channel Connections - Introduction

Channel connections are available in three series which are used with channels HMPC-41/41, HMPC 41/21; HMPB 36/36; HMPB 28/28 and HMPB 28/15. The following product codes should be used when ordering.

Product Code

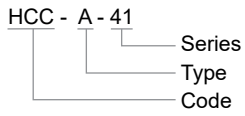

Series 41

For channels:
HMPC 41/41
HMPC 41/21

Series 36

For channels:
HMPB 36/36

Series 28

For channels:
HMPB 28/28
HMPB 28/15



HTB T Bolts & HMLN Lock Nuts - Product Details

HTB T bolts and HMLN lock nuts for attachments into HMP channels are specially designed for a perfect fit into the section of the channels. Insertion is made and after a 90 degree turn clockwise the fixing is made. Correct torque values must be applied in order to achieve secure connections.

T bolts and lock nuts are available in stainless steel 1.4401 and hot dip galvanised steel strength class 4.6 & 8.8.



Thread Bolt Metric Size	Grade	Loading Table for Thread Bolts (kN)												Max Torque Loads (Nm)			
		4.6 class Steel			8.8 class Steel			Stainless Steel W 1.4401 / A4-50			Stainless Steel W 1.4401 / A4-70			4.6 Class Steel	8.8 Class Steel	W 1.4401 A4-50	W 1.4401 A4-70
		Tensile & Shear	Bending Moment	Longitudi- nal Load	Tensile & Shear	Bending Moment	Longitudi- nal Load	Tensile & Shear	Bending Moment	Longitudi- nal Load	Tensile & Shear	Bending Moment	Longitudi- nal Load				
M6	<i>all. F</i>	2,2	2,0	0,10	-	-	-	2,2	1,8	0,1	3,0	3,8	0,1	3	-	3	4
M8	<i>all. F</i>	4,0	5,0	0,20	-	-	-	4,0	4,4	0,2	5,5	9,4	0,3	8	-	8	10
M10	<i>all. F</i>	6,4	10,0	0,30	13,3	24,9	1,1	6,4	8,7	0,3	8,7	18,7	0,4	15	48	15	20
M12	<i>all. F</i>	9,3	17,5	0,50	19,4	43,7	1,6	9,3	15,3	0,5	12,6	32,8	0,7	25	70	25	35
M16	<i>all. F</i>	17,3	44,4	0,90	36,1	110,0	3,0	17,3	38,8	0,9	23,6	83,3	1,2	60	200	60	80
M20	<i>all. F</i>	27,0	86,5	1,40	56,4	216,4	4,7	27,0	75,7	1,4	36,8	162,3	1,9	120	400	120	160

Allowable Loads For Locknuts

Lock Nut Type	Tensile (kN)
HMLN-28-6	1,9
HMLN-28-8	2,8
HMLN-28-10	3,0
HMLN-38-8	4,0
HMLN-38-10	4,1
HMLN-38-12	5,7
HMLN-41-6	4,0
HMLN-41-8	4,0
HMLN-41-10	6,4
HMLN-41-12	9,3
HMLN-40-8	4,0
HMLN-40-10	6,4
HMLN-40-12	9,3
HMLN-50-10	6,4
HMLN-50-12	9,3
HMLN-50-16	9,3

Lock Nut Type	Shear (kN)
HMLN-41-6	2,2
HMLN-41-8	4,0
HMLN-41-10	5,0
HMLN-41-12	5,0

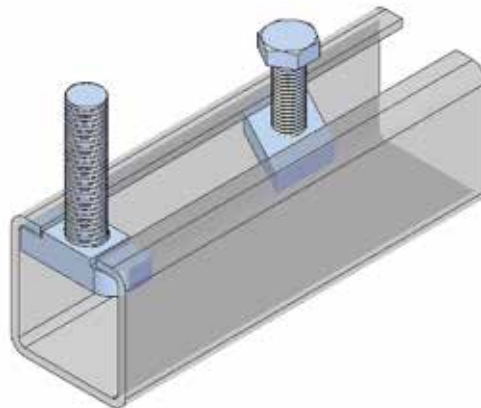

HTB T bolts and HMLN Lock nuts are fixed on to HMP channels at desired positions along the length of the channels and are fixed by turning 90 degrees.

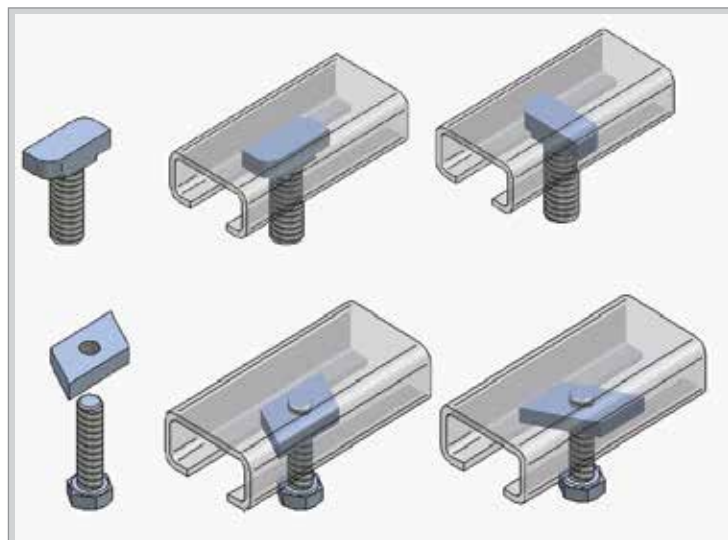

HTB T Bolts & HMLN Lock Nuts - Technical Details

HTB-T Head Bolts

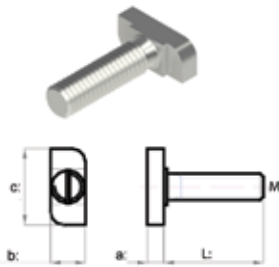

HTB-28 - T Bolt

	Code	Size (MxL)
a : 4 mm	HTB-28-8/30	M8x30
b : 10.5 mm	HTB-28-10/40	M10x40
c : 23 mm	HTB-28-12/50	M12x50

For Channel type HMPR-28/15

HTB-38 - T Bolt

	Code	Size (MxL)
a : 7 mm	HTB-38-10/40	M10x40
b : 13 mm	HTB-38-12/50	M12x50
c : 30.5 mm	HTB-38-16/60	M16x60

For Channel type HMPR-38/17

HTB-40 - T Bolt

	Code	Size (MxL)
a : 12 mm	HTB-40-10/40	M10x40
b : 14 mm	HTB-40-12/50	M12x50
c : 34 mm	HTB-40-16/60	M16x60

For Channel type HMPR-40/25

HTB-50 - T Bolt

	Code	Size (MxL)
a : 13 mm	HTB-50-12/50	M12x50
b : 17.5 mm	HTB-50-16/60	M16x60
c : 42 mm	HTB-50-20/80	M20x80

For Channel type HMPR-49/30 & HMPR-54/33

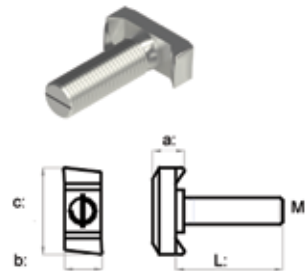

HTB-41 - T Bolt

	Code	Size (MxL)
a : 10 mm	HTB-C-41-12/50	M12x50
b : 20 mm	HTB-C-41-16/60	M16x60
c : 34 mm		

For Toothed Channel type HMPR-41/22

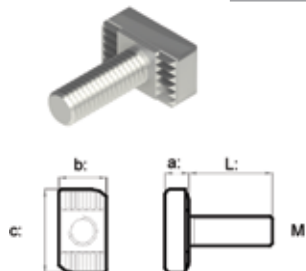

HMLN - Lock Nuts

HMLN-28 - Lock Nut

	Code	Size (MxL)
a : 4 mm	HTB-28-6	M6
b : 13 mm	HTB-28-8	M8
c : 24.5 mm	HTB-28-10	M10

For Channel type HMPR-28/15

HMLN-38 - Lock Nut

	Code	Size (MxL)
a : 6 mm	HTB-38-10	M10
b : 17.5 mm	HTB-38-12	M12
c : 31.5 mm	HTB-38-16	M16

For Channel type HMPR-38/17



HMLN-40 - Lock Nut

	Code	Size (MxL)
a : 10.8 mm	HTB-28-6	M6
b : 17 mm	HTB-28-8	M8
c : 34.5 mm	HTB-28-10	M10

For Channel type HMPR-40/25

HMLN-49 - Lock Nut

	Code	Size (MxL)
a : 11.7 mm	HTB-49-10	M10
b : 21 mm	HTB-49-12	M12
c : 43.5 mm	HTB-49-16	M16

For Channel type HMPR-49/30 & HMPR-54/33

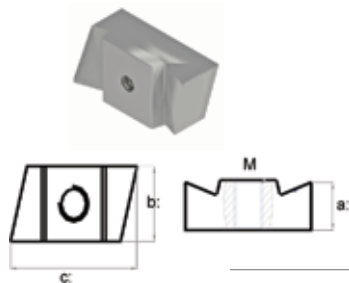

HMLN-41 - Lock Nut

Code	Size	M
HMLN-41-6	6x20x34	M6
HMLN-41-8	8x20x34	M8
HMLN-41-10	9x20x34	M10
HMLN-41-12	10x20x34	M12

For Toothed Channel type HMPR-41/22

HMLN-S-41 - Lock Nut

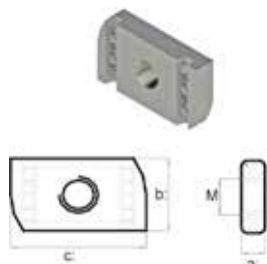

HMP Steel Sub Channel Application Pictures

HMCI concrete inserts are produced from 41/41 & 41/21 C channels with pressed out strips that are punched out at 100 mm centres. These channels are used for casting in to concrete to enable connections without drilling. Various applications for connections to floors, walls, and ceilings are made for the installation of secondary structures. **HMLN** lock nuts can be inserted anywhere along the length of the channels. The channels are supplied with an easily removable strip, which prevents the ingress of grout and cement. Concrete inserts can be supplied in electro galvanised, hot dip galvanised and stainless steel finishes.

Advantages

- * No Drilling
- * Fast and easy fixing
- * No need for electricity
- * No dust when constructing.
- * Economic through less workmanship

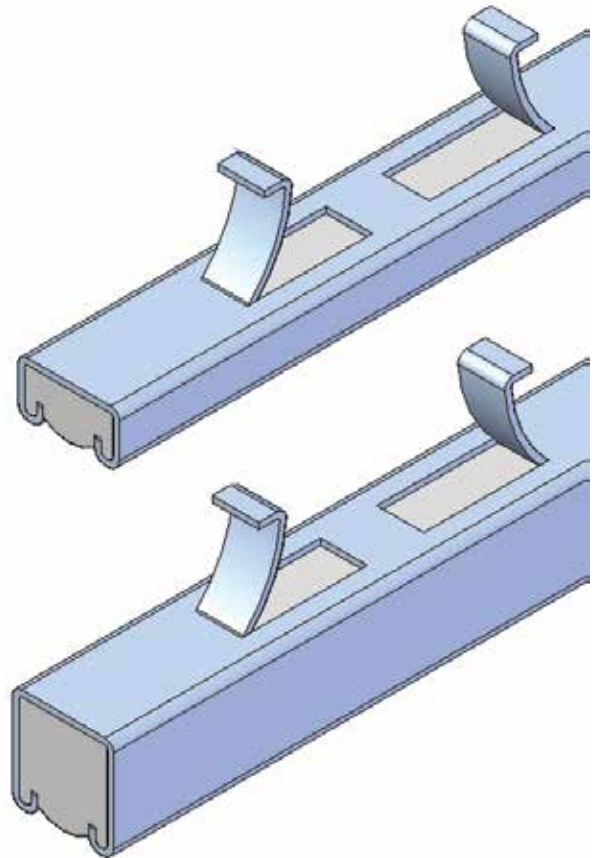

Installation Instruction

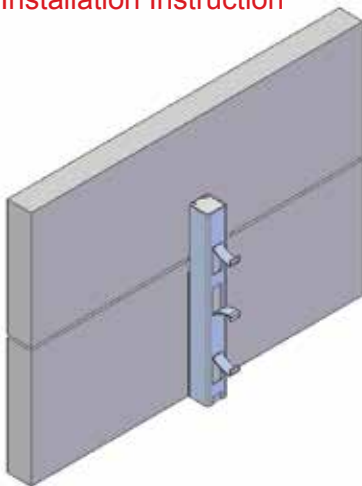

1.) HMCI concrete inserts are nailed on to the form work at the required location, prior to casting of the concrete.

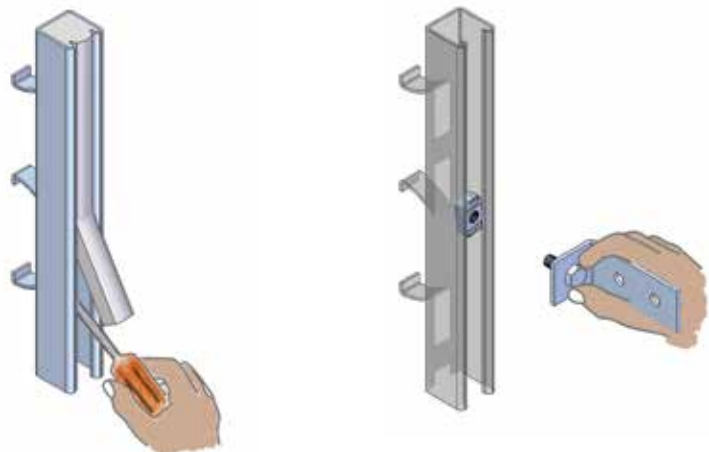

2.) After the concrete has dried, then the filler is removed by using a screw driver or similar tool.

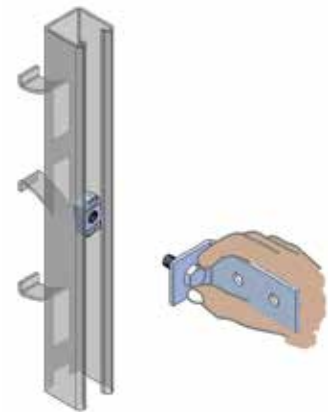

3.) Fixing is done at the desired position along the length of the channel. Installation is made with lock nuts and set screws.

The strips pressed out of the back of the HMCI concrete inserts are designed to provide positive anchoring in to the concrete. Distortion of the pressed strips is not recommended as it will severely reduce the performance of the insert. HMCI concrete inserts are either point welded or wired to steel reinforcement. HMCI concrete inserts are supplied with a filler to prevent the ingress of grout and cement in to the channel slot.

HMCI Concrete Inserts - Technical Details

HMCI-41/21 Concrete Insert

6.7 kN pull out admissible load per 300 mm span

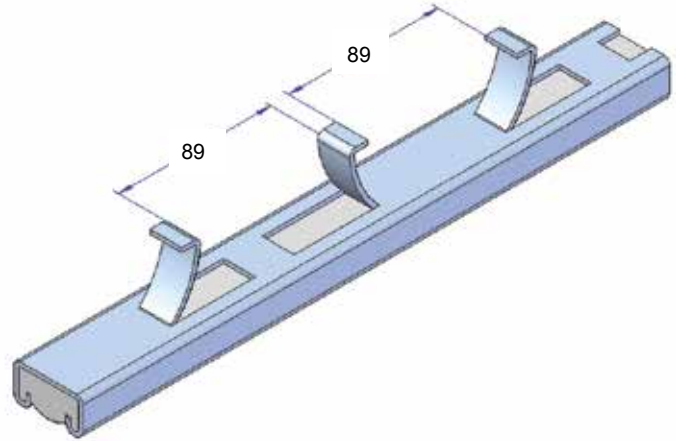
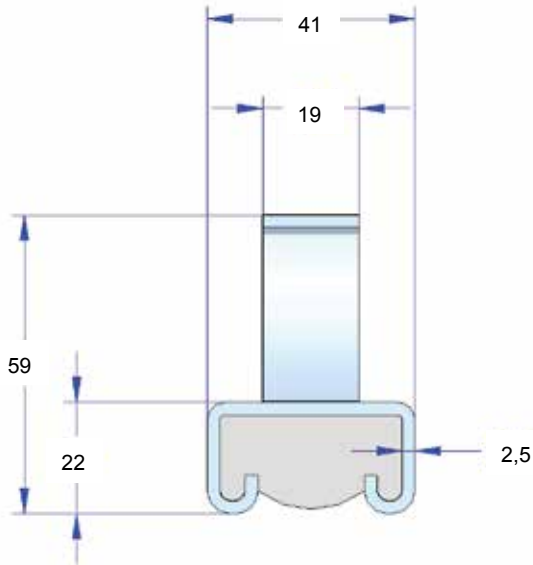

HMCI-41/41 Concrete Insert

8.8 kN pull out admissible load per 300 mm span

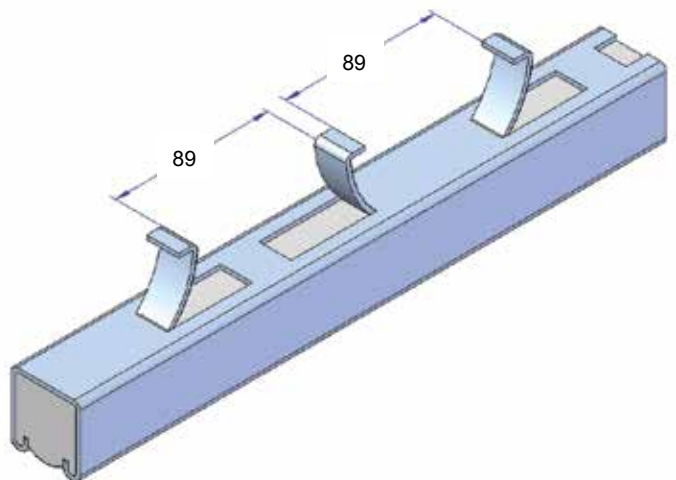
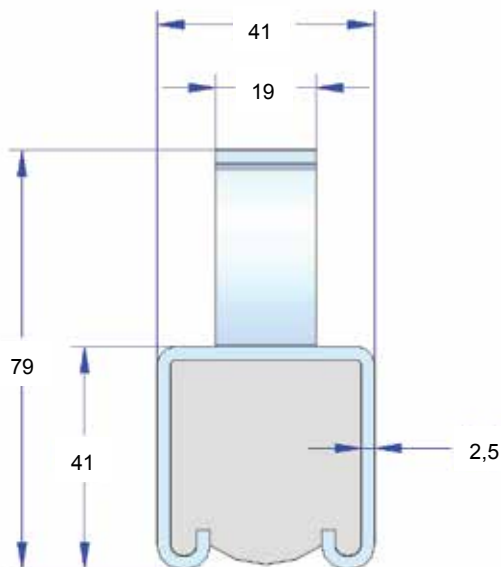

Code	Size	Length
HMCI-41/21	2,5x41/21	6000
HMCI-41/41	2,5x41/41	6000

- M6, M8, M10, M12 size lock nuts are used for fastening fixtures on to the concrete inserts.
- Standard stock lengths are 6000 mm. Special length fabrication can be made upon request.
- Material: A2: Stainless steel EN 1.4301, A4 Stainless steel EN 1.4401, HDG hot dip galvanized mild steel 1.0038 (S235JR), EG Electro galvanized mild steel 1.0038 (S235JR).

HPCL Pipe Clamps - Introduction

HPCL pipe clamps are designed to be used in combination with HMP framing channel systems. Optimum material efficiency is provided through dimensioning according to related requirements.

The HPCL pipe clamps are available in a range between 13 mm to 508 mm. When using HPCL pipe clamps in combination with the HMP framing channels, spatial adjustability in all directions is enabled.

Advantages

- Quick and easy fixing.
- Cost effective and flexible.
- Compatible with HMP framing.
- Assembly with T bolts or lock nuts.
- Full adjustability when used in combination with HMP channels.

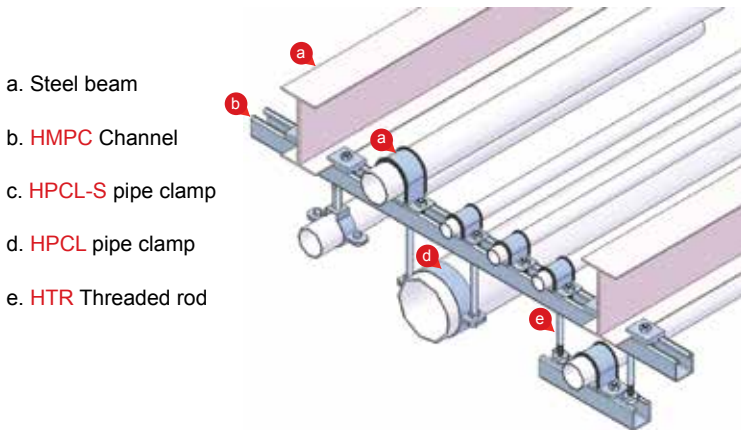

- a. Steel beam
- b. HMP Channel
- c. HPCL-S pipe clamp
- d. HMP bracket
- e. HTR Threaded rod

In combination with HMP and HMPR channels

HPCL pipe clamps are fixed on to HMP and HMPR channels with HMLN lock nuts, HTB T bolts and HTR Threaded rods. Easy and quick fixing is enabled.

Pipe line installation made on self supporting structures that are built with HMP framing systems. HPCL-S pipe clamps are fixed on to the HMC brackets with lock nuts or T bolts.

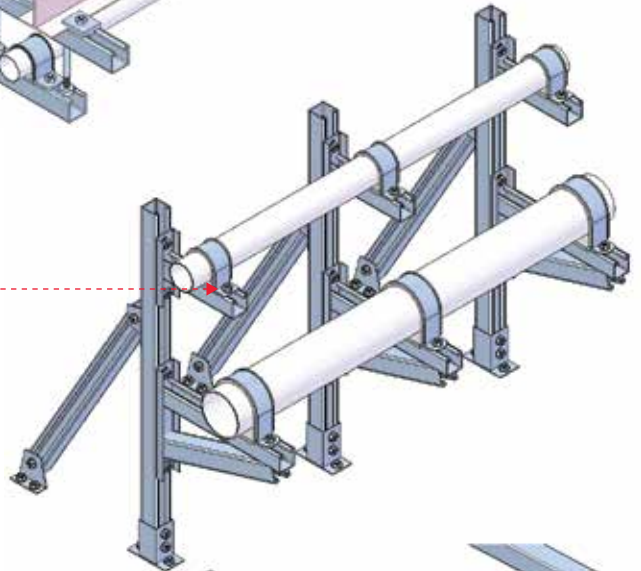
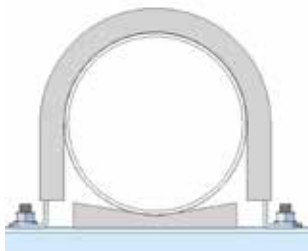

Pipe line installation suspended on HMP C channels. HPCL pipe clamps are suspended on to the channels with HTR threaded rods and HMLN lock nuts.

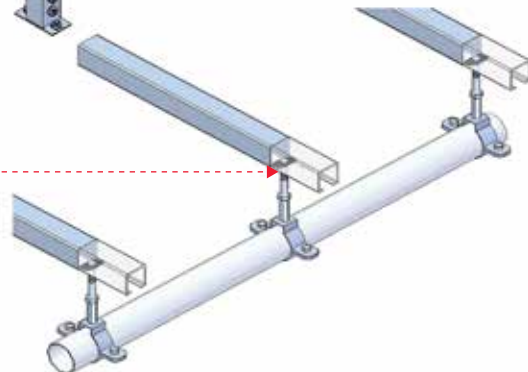
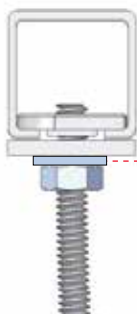

HPCL Pipe Clamps - Product Details

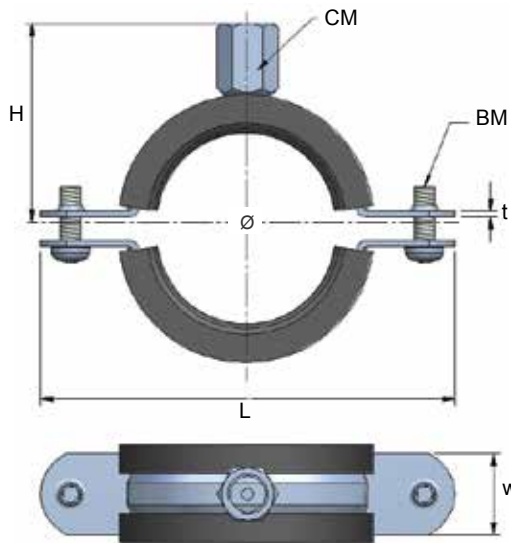

Specifications

- Used for the installation of pipe lines on to walls and framing systems.
- Fixing is made through M8/M10 combi nuts. Normal nuts also available.
- Easy and safe assembly with combi screws.
- Side screws are protected against loss during assembly with plastic washers.
- Electro galvanized for corrosion resistance (Plating thickness 8-10 micron).
- Available with sound insulation rubber or without rubber.

Product Type	Technical Details							Loading Table		
	Diameter	Spanning Range	Length	Height	Bolt	Dimensions	Combi Nut	Size	Breaking Load	Allowable Load
	Ø (mm)	(mm)	L (mm)	H (mm)	BM	txw (mm)	CM	Ø (mm)	(kN)	(kN)
HPCL-13	13	11-15	54,5	32	M5	1.5x20	M8 / M10	13-34	3,9	1,3
HPCL-18	18	16-20	58,5	34	M5	1.5x20	M8 / M10	42,5-64	4,8	1,6
HPCL-21,5	21,5	20-24	62,5	36	M5	1.5x20	M8 / M10	70-105	7,8	2,6
HPCL-27	27	25-30	68,5	39	M5	1.5x20	M8 / M10	110-212	7,8	2,6
HPCL-34	34	32-38	76	42,5	M5	1.5x20	M8 / M10			
HPCL-42,5	42,5	39-46	91,5	47	M6	1.5x20	M8 / M10			
HPCL-50	50	48-53	99	50,5	M6	1.5x20	M8 / M10			
HPCL-56	56	54-58	105	53,5	M6	1.5x20	M8 / M10			
HPCL-64	64	59-66	112	57	M6	1.5x20	M8 / M10			
HPCL-70	70	67-73	125	62	M6	2x25	M8 / M10			
HPCL-77	77	74-80	134	66	M6	2x25	M8 / M10			
HPCL-84	84	80-87	141	70	M6	2x25	M8 / M10			
HPCL-89	89	87-94	146,5	71,5	M6	2x25	M8 / M10			
HPCL-95	95	95-98	151	75,5	M6	2x25	M8 / M10			
HPCL-105	105	99-108	159,5	79,5	M6	2x25	M8 / M10			
HPCL-110	110	108-116	173	85	M6	2.5x25	M8 / M10			
HPCL-125	125	120-129	186	91,5	M6	2.5x25	M8 / M10			
HPCL-131	131	129-135	192	94,5	M6	2.5x25	M8 / M10			
HPCL-137	137	135-143	199	98	M6	2.5x25	M8 / M10			
HPCL-150	150	149-168	215	106	M6	2.5x25	M8 / M10			
HPCL-160	160	162-170	227	110,5	M6	2.5x25	M8 / M10			
HPCL-200	200	198-207	264	131	M6	2.5x25	M8 / M10			
HPCL-212	212	206-220	280,7	138	M6	2.5x25	M8 / M10			

Product Code

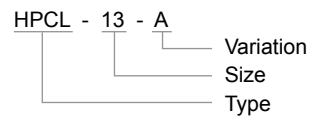

Variation A
With combi nut and rubber



Variation B
With combi nut and without rubber



Variation C
With normal nut and rubber



Variation D
With normal nut and without rubber



HPCL-H Pipe Clamps - Product Details

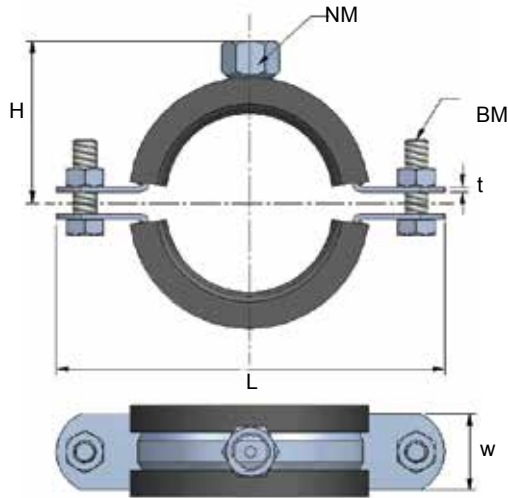

Specifications

- Used for the installation of pipe lines on to walls and framing systems.
- Used for high load pipe lining installations.
- Fixing is made through M12 & M16 nuts.
- Electro galvanized for corrosion resistance (Plating thickness 8-10 micron).
- Stainless steel is also available.
- Available with & without sound insulation rubber.

Product Type	Technical Details							Loading Table		
	Diameter	Spanning range	Length	Height	Bolt	Dimensions	Nut	Size	Breaking Load	Allowable Load
	mm	Ø (mm)	L (mm)	H (mm)	BM	txw (mm)	NM	Inch (')	(kN)	(kN)
HPCL-H 21,5	21,5	20-24	84	32	M8	2.5x30	M12	21,5-60	11	2,75
HPCL-H 27	27	25-30	90	35	M8	2.5x30	M12	70 - 125	15	3,75
HPCL-H 34	34	32-38	98	39	M8	2.5x30	M12	131 - 267	24	6
HPCL-H 42,5	42,5	39-46	106	43	M8	2.5x30	M12	326-508	35,1	11,7
HPCL-H 50	50	48-53	114,5	47	M8	2.5x30	M12			
HPCL-H 56	56	54-58	120,5	50	M8	2.5x30	M12			
HPCL-H 64	64	59-66	127	53	M8	2.5x30	M12			
HPCL-H 70	70	67-73	143,5	58	M10	3x30	M12			
HPCL-H 77	77	74-80	152	62	M10	3x30	M12			
HPCL-H 84	84	80-87	160	66	M10	3x30	M12			
HPCL-H 89	89	87-94	163	67,5	M10	3x30	M12			
HPCL-H 96	96	95-98	171	71,5	M10	3x30	M12			
HPCL-H 105	105	99-108	179	75,5	M10	3x30	M12			
HPCL-H 110	110	108-116	188	80	M10	3x30	M12			
HPCL-H 125	125	120-129	201	86,5	M10	3x30	M12			
HPCL-H 131	131	129-135	226,5	95,5	M12	4x40	M16			
HPCL-H 137	137	135-143	233,5	99	M12	4x40	M16			
HPCL-H 160	160	162-168	256,5	106,5	M12	4x40	M16			
HPCL-H 212	212	206-220	316	133	M12	4x40	M16			
HPCL-H 267	267	260-274	365	160,5	M12	4x40	M16			
HPCL-H 326	326	324	421	186	M16	5x50	M16			
HPCL-H 355	355	355,6	453	201,5	M16	5x50	M16			
HPCL-H 406	406	406,4	504,5	227,5	M16	5x50	M16			
HPCL-H 457	457	457	564,2	244,5	M16	7x70	M16			
HPCL-H 508	508	508	621,5	273,5	M16	7x70	M16			

Product Code

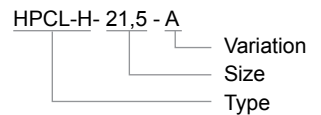

Variation A
With nut and rubber



Variation B
With nut and without rubber



Variation C
With two nuts and rubber



Variation D
With two nuts and without rubber



Variation E
Without nut and with rubber



Variation F
Without nut and without rubber



Variation G
With welded bracket and rubber



HPCL-S Pipe Clamps - Product Details

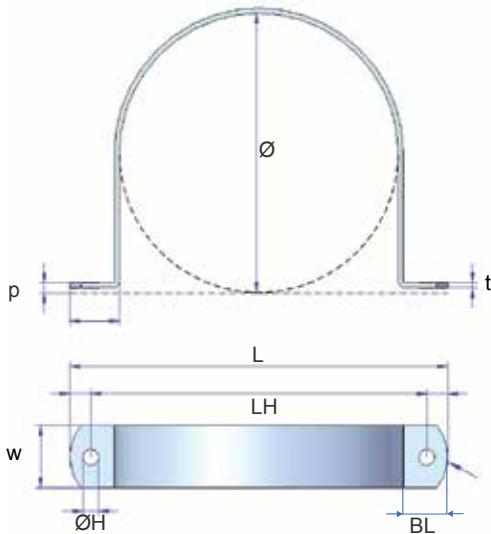

Specifications

- Used for the installation of pipe lines on to HMC Brackets and HMP Framing systems.
- Fixing is made with T bolts or lock nuts.
- Rubber base is available for placing between pipe clamp and ground base.
- Electro galvanized for corrosion resistance (Coating thickness 8-10 micron).
- Stainless steel is also available.
- Available with sound insulation rubber or without rubber.

Product Type	Technical Details							
	Clamp Diameter Ø (mm)	Span Range (mm)	Length L (mm)	Distance Between Holes LH (mm)	Hole Diameter ØH (mm)	Dimensions txw (mm)	Base Length BL (mm)	Pretension Dimension p (mm)
HPCL-S 21,5	21,5	20-24	77	55	11	3x25	30	2,75
HPCL-S 27	27	25-30	87	61	11	3x25	30	2,75
HPCL-S 33,5	33,5	33,5	93,5	67,5	11	3x25	30	2,75
HPCL-S 42,5	42,5	39-46	102,5	76,5	11	3x25	30	2,75
HPCL-S 50	50	48-53	110	84	11	3x25	30	2,75
HPCL-S 60	60	59-66	120	94	11	3x25	30	2,75
HPCL-S 77	77	74-80	111	137	11	3x25	30	2,75
HPCL-S 89	89	87-94	149	123	11	3x25	30	2,75
HPCL-S 110	110	108-116	170	144	11	4x30	30	4
HPCL-S 137	137	135-143	197	171	11	4x30	30	4
HPCL-S 160	160	158-162	240	208	13	4x40	40	4
HPCL-S 212	212	210-214	292	260	13	4x40	40	4
HPCL-S 267	267	265-269	367	317	17	5x50	50	5
HPCL-S 326	326	324-328	426	376	17	5x50	50	5
HPCL-S 355	355	355,6	455	405	17	5x50	50	5
HPCL-S 406	406	406,4	506	456	17	5x50	50	5
HPCL-S 508	508	508	608	558	17	5x50	50	5

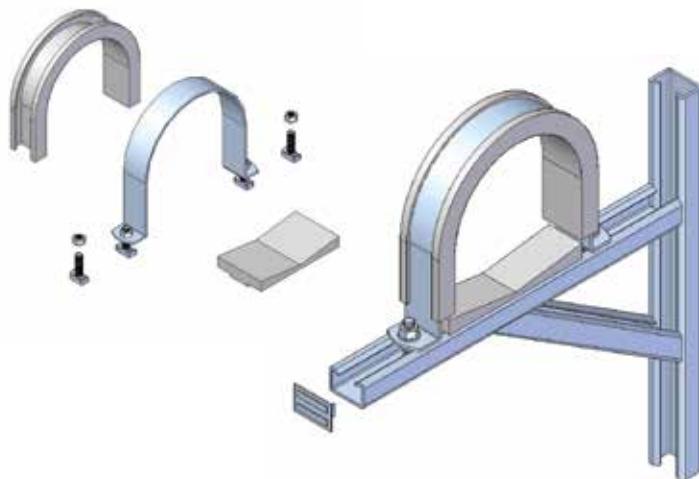

Product Code

HPCL-S - 21,5 - A

Variation
Size
Type

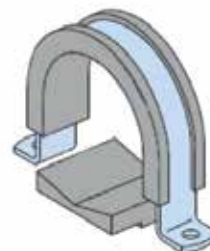

Variation A
With combi nut and rubber



Variation B
With combi nut and without rubber

Rubber base available for placing below the pipes for sound installation and firmer fixing on to channels or brackets.

Accessories - Product Details

HLW3 Lock Washer



- Lock nut used to firmly stabilize any fixture made on the channels with lock nuts or T bolts.
- For Channels 28/15, 28/28, 38/17, 36/36, 41/21 & 41/41



HUB U Shape Bolt



- U Bolts are used for the connection of pipes to structures for lateral fixing.
- Sizes available in M6, M8, M10, M12, M16 to suit diameter sizes up to 355mm



HBC-P Beam Clamp



- Beam clamp is used for connection of slotted channels to steel beams.
- Applicable for all channels with slotted holes.
- Maximum load is 7.0 kN.



HBC-M Beam Clamp



- Beam clamp is used for the connection of threaded rods to steel beams.
- Applicable for M8 and M10 threaded rods.
- Maximum load is 2.5 kN.

HBC-U Beam Clamp



- Beam clamps for the connection of channels without slotted holes.
- For Channels 41/41 B & 40/25 B.



HBC-U 127 Beam Clamp



- Beam clamps for the connection of channels without slotted holes.
- For Channels 41/21, 41/41 and 40/25.

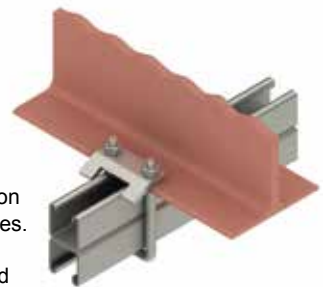

HEC-1 End Cap



- Channel end caps available for channels 28/28, 36/36, 41/21, 41/41 & 40/25.



HEC-2 End Cap



HSI Sound Isolator

- Sound isolator sleeve available for channels 28/28, 36/36, 41/21 & 41/41.



Accessories - Product Details

HTR Threaded Rod



Code	Metric Size	Tensile Load (kN)
HTR-6	M6	2.2
HTR-8	M8	4.0
HTR-10	M10	6.4
HTR-12	M12	9.3
HTR-16	M16	17.3

HRSL Ring Sleeve



Code	Size	Tensile Load (kN)
HRSL-6	M6x35	1.6
HRSL-8	M8x60	2.0
HRSL-10	M10x60	4.0
HRSL-12	M12x60	4.6
HRSL16	M16x80	8.3

HHCS Hex Coupler



Code	Metric Size	Tensile Load (kN)
HHCS-6	M6	2.2
HHCS-8	M8	4.0
HHCS-10	M10	6.4
HHCS-12	M12	9.3
HHCS-16	M16	17.3

HRCS Round Coupler Sleeve



Code	Metric Size	Tensile Load (kN)
HCS-6	M6	2.2
HCS-8	M8	4.0
HCS-10	M10	6.4
HCS-12	M12	9.3
HCS-16	M16	17.3

HTBC Turnbuckle



Code	Metric Size	Tensile Load (kN)
HTBC-6	M6	2.2
HTBC-8	M8	4.0
HTBC-10	M10	6.4
HTBC-12	M12	9.3

HRB Ring Bolt



Code	Metric Size	Tensile Load (kN)
HRB-6	M6x50	2.2
HRB-8	M8x50	4.0
HRB-10	M10x55	6.4
HRB-12	M12x80	9.3

HIRN Ring Nut



Code	Metric Size	Tensile Load (kN)
HTBC-6	M6	2.2
HTBC-8	M8	4.0
HTBC-10	M10	6.4
HTBC-12	M12	9.3

HLW1 Lock Washer



Code	Metric Size	Tensile Load (kN)
HLW1-340-9	ø9	3x40x40
HLW1-340-11	ø11	5x50x50
HLW1-440-11	ø11	5x50x50
HLW1-440-13	ø13	5x50x50
HLW1-440-17	ø17	5x50x50

DIN933 Hex Bolt



Code	Metric Size
DIN933-6/30	M6x30
DIN933-8/30	M8x30
DIN933-10/40	M10x40
DIN933-12/50	M12x50
DIN933-16/60	M16x60

DIN934 Hex Nut



Code	Metric Size
DIN934-6	M6
DIN934-8	M8
DIN934-10	M10
DIN934-12	M12
DIN934-16	M16

DIN125 Round Washer



Code	Metric Size
DIN125-6	M6
DIN125-8	M8
DIN125-10	M10
DIN125-12	M12
DIN125-16	M16

DIN 9021 Wide Washer



Code	Metric Size
DIN9021-6	M6
DIN9021-8	M8
DIN9021-10	M10
DIN9021-12	M12
DIN9021-16	M16

HMP Framing Systems - Application Examples

HMP Framing systems with channels and various accessories are used to build steel construction for the installation various type of structures. Efficient modular support structures are built quickly and easily. Flexible and low cost application is achieved.



Advantages:

- Fast and Secure fixing.
- No time consuming welding and hole setting.
- No use of welding and drilling equipment.
- Adjustable and no slip point fixing.
- Cost effective and flexible.
- Quick and easy fixing.



• Installation of infrastructure utilities.

• Installation of electrical cables.

• Installation of lighting systems.



• Assembly made on to steel beams.

• Assembly made on to concrete floors.

• Assembly made on to cast in channels.

HMP Framing Systems - Application Examples



• Installation of pipe and duct systems.



• Pipe connections to lateral walls.



• Assembly for connection to steel beam.

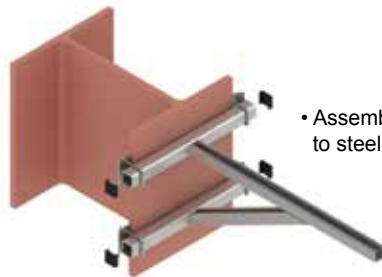

• Assembly for connection to steel structure.

• Assembly for connection to concrete floor.



• Assembly for connection to column.

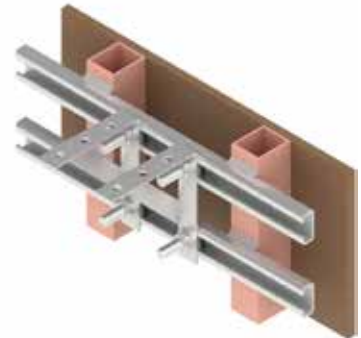

• Bolt connection to steel.



• Weld connection to steel.



• Bolt connection to block work.



• Bolt connection to concrete.



Notes

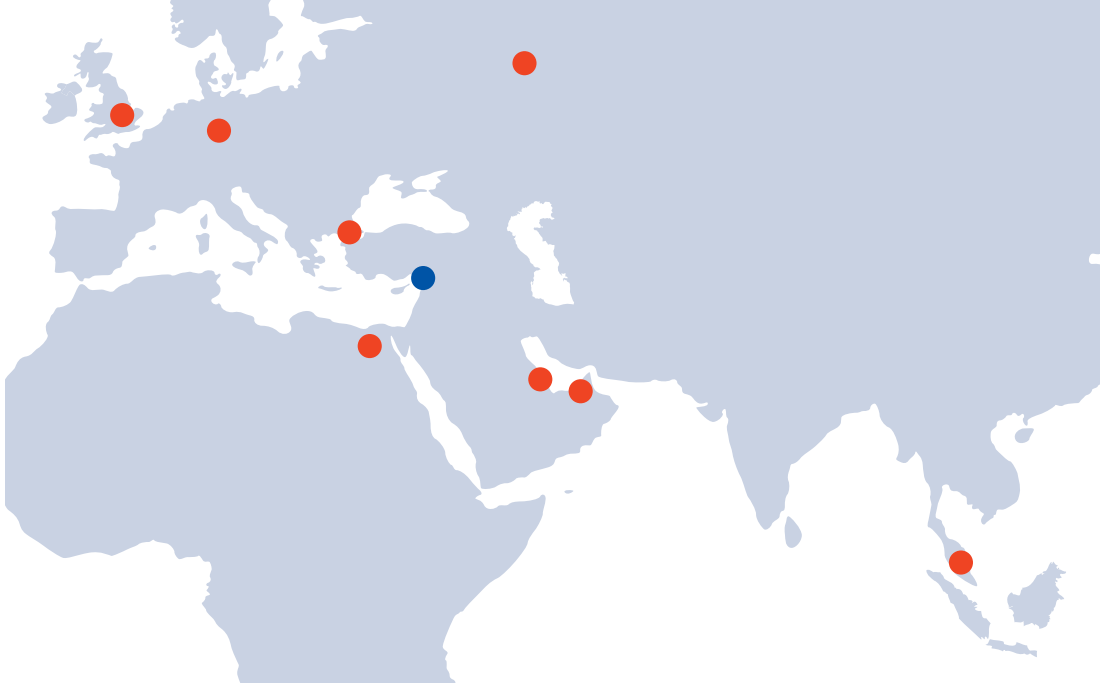

HAZ PAZARLAMA İÇ & DIŞ TİC. A.Ş.
İçerenköy Mh. Çayır Cd. Özce Center
No:3 K:12 34752 Ataşehir
İstanbul, TÜRKİYE
Tel : +90 (0) 216 410 72 06
Fax : +90 (0) 216 410 71 41
www.hazpazarlama.com
hazpazarlama@hazgrp.com

HAZ INTERNATIONAL LTD.
154 Great North Road Hatfield
Herts. AL9 5JN England
Tel : +44 (0) 1707 - 260 180
Fax : +44 (0) 1707 - 260 190
www.hazuk.co.uk
haz@hazuk.co.uk

HAZ EGYPT LTD
Villa no.29-Third Floor.St.no.270
New Maadi, Cairo, Egypt
Tel : +20 (2) 2447 09 85
www.hazeg.com
info@hazeg.com

HAZ METAL SANAYİ VE TİCARET A.Ş.
Şehit Er Çıracı Caddesi No. 10
Akçay Sanayi Bölgesi 31200 İskenderun
Hatay, TÜRKİYE
Tel : +90 (0) 326 626 20 50
Fax : +90 (0) 326 626 20 45
www.hazmetal.com
info@hazmetal.com

HAZ MARBLE INDUSTRY & TRADE LLC
First Gulf Building Corniche Street
2nd Floor, Flat No. 202 P.O. Box 5721
Abu Dhabi, United Arab Emirates
Tel : +971 (0) 2 622 07 00
Fax : +971 (0) 2 622 17 00
www.hazuae.ae
hazuae@hazmarbleuae.ae

HAZ MARBLE QATAR WLL
P.O.BOX 31296 C-Ring road
Doha, Qatar
Tel : +974 (4) 467 26 13-47
Fax : +974 (4) 467 47 49
www.hazqatar.com
hazdoha@hazqatar.com

HAZ METAL DEUTSCHLAND GmbH
Leonhard Karl Strasse 29
97877 Wertheim, Germany
Tel : +49 (0) 9342 93590
Fax : +49 (0) 9342 935929
www.hazmetal.de
info@hazmetal.de

HAZ ASIA PACIFIC PTE LTD
Blk 22 Woodlands Link #01-65
Singapore 738734
Tel: +65 6853 7681
Fax: +65 6752 9582
www.hazapac.com
info@hazapac.com

HAZ RUS LTD
117036, UI, Profsoyuznaya Dom 3 (office 531)
Moscow, Russian Federation
Tel : +7 (926) 672 31 84
info@hazrus.ru
www.hazrus.ru



Always at the forefront of fixing technology, HAZ METAL has earned a reputation as the leaders in fixing systems innovation and is regarded as the one to follow. HAZ METAL fixing systems of today become the standard of tomorrow.

HAZ METAL combines the very latest international technology with its own research and development team to establish a technical excellence within the industry. HAZ METAL readily embraces the responsibility of a major producer and shares its expertise with problem solving solutions.