

HAZ METAL FIXING SYSTEMS

Your Fixing Systems Specialist

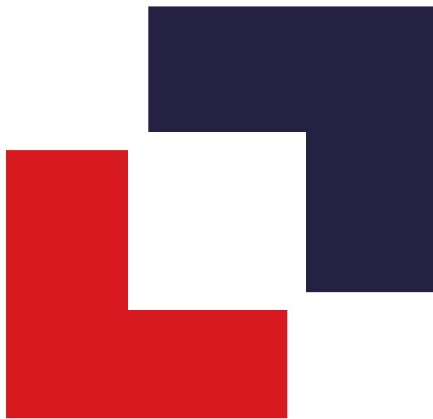

Brickwork Support Systems
Technical Product Catalogue
HAZ-BS-EN/04.20





Bosmos Flats, Switzerland

Contents

Company Profile	1	HMS-AV & AVS Angled Brackets	39
Brickwork Support Systems Overview	3	HMS-ES & GS Prefabricated Component Inserts	41
Brickwork Support Systems Design Principles	5	HMS-AW Special Restraint Channel	42
FIX Brickwork Support Brackets Introduction	9	HWP Wind Post Restraints Introduction	43
Brickwork Support System Product Range	10	HLS Brickwork Lintel Supports Introduction	45
FIX Brickwork Support Brackets Product Details	11	HMP Brickwork Wall Tie Channels	49
FIX Brickwork Support Bracket Load Table	12	HWT-M Brickwork Wall Ties	50
FIX Brickwork Support Bracket Application Guide	13	HRST Restraining Ties	51
FIX Brickwork Support Bracket Technical Details	19	CMWT Brickwork Wall Ties Product Details	52
Brickwork Support Systems - Application Examples	31	HMHR Brickwork Head Restraints	55
ISO-FIX Brickwork Support Brackets Introduction	33	Connections Methods to Concrete	57
FIX Adjustable Plate Introduction	34	Scaffolding Anchors Product Details	58
HMCS Continuous Brickwork Support Introduction	35	References	59
HMCS Continuous Supports Product Details	36		



Company Profile

Introduction

HAZ Metal is located in Iskenderun, in the southern part of Turkey, based in the company owned property, with an area of 17.000 square meters.

The company provides services in the design and production of stainless steel fixing systems for natural stone installation and a variety of products used in construction.

The company's objective is to assist and advise its clients in choosing the most suitable fixing systems for their requirements and to provide them with quality production and supply with timely deliveries.

HAZ Metal has dedicated itself to supplying its clients with easy to use, secure and economical fixing systems. Along with this principle, HAZ Metal has organized a technical department to design and produce fixing systems in accordance with international standards.

HAZ Metal has 200 employees working both in Turkey and in its foreign branches. Along with a sales office in Istanbul, Turkey, there are HAZ branches in the United Arab Emirates, Germany, the United Kingdom, Russia, Qatar, Egypt and Singapore. With this network, HAZ Metal reaches out closer to its clients, to provide better services to meet local requirements.

The innovative design and production techniques offer practical and economic solutions to solve every possible problem within the scope of natural stone installation. As a supplier of fixing systems to major projects around the world, HAZ Metal has proven its quality and reliability to its clients. The company enjoys serving the sector and works hard to constantly improve and develop its services.

Product Range

HAZ Metal started producing fixing systems in 1993. Today, the company has the technical know how and technology to produce all types of natural stone fixing systems used for ventilated stone facades. Production of a variety of fixing systems such as channels, anchor channels, brickwork support anchors and anchor bolts is also available.

- Sub channel systems
- Anchor channel systems
- Framing systems
- Masonry support systems
- Structural building components.
- Anchor bolts.
- Various construction accessories.

Standard and customized production is made to meet the special application requirements.



Production Capacity

HAZ Metal has the capacity to produce over 300 tons of materials every month with over 100 production units and work stations. The production plant boast a series of high grade machinery ranging from a slitting line to eccentric presses and 6 meter press brakes.

There is well equipped welding unit with proper welding benches and a welding robot that does precision welding. Two automated welding units are also available for the fast and economic process. All of the operators in the welding unit are certified and carry licenses from Lloyds quality assurance institute.

Technical Know-How

HAZ Metal's technical staff, each with more than 10 years experience, has an outstanding technical knowledge in the field of stainless steel production.

The maintenance of the machines and the preparation of moulds for production are done in the company's workshop. This ensures higher efficiency and productivity in production, increasing the quality of services with competitive prices.

Welding processes are well understood and controlled by the experienced and responsible staff. In ensuring high quality welding of steel and stainless steel, highly skilled, certified operators are recruited for the welding unit. Appropriate machines and welding techniques are in use to offer the structural integrity of the welded products.

Quality Standards

HAZ Metal implements EN and ASTM standards in the production of channels. Production is strictly controlled within the tolerances of these standards.

All products are produced by its personnel, applying the latest production methods with advanced machinery. The quality control team, under the supervision of a mechanical engineer, is selected from long serving and experienced foremen.

Production is checked during each production step and is compared with production drawings and specifications. The company is strictly bound to the concept of ISO 9001:2008 and "Total Quality Management" system. A quality assurance system is set up and is running to cover the control of each process in manufacturing. The control checks are documented and recorded.

The application of this management system is maintained and is a part of day to day operations. HAZ Metal gives great emphasis in keeping the high level quality of manufacturing and strides to improve its processes to meet the increasing demands of the construction industry.



HAZ METAL
FIXING SYSTEMS

Your Fixing Systems Specialist



HAZ Metal is certified with integrated management systems by TUV SUD for ISO 9001:2008, ISO 14001:2004 & OHSAS 18001:2007 standards

FIX Brickwork Support Systems - Overview

FIX brickwork support systems are used for the secure and easy installation of brickwork facades. The **FIX** brickwork brackets are used to transfer the dead loads of non load bearing outer shell brickwork walls to the load bearing inner walls of buildings. Load bearing brickwork support brackets are fixed on concrete beams which carry the dead load of the facade. **HRST** Restraints ties or **HWT-M** wall ties are used along the rest of the storey height to secure the brickwork facade against wind loads.

FIX brickwork support systems provide support for brickwork as non-load bearing external cladding which is attached on the substrate. The relatively thin outer skin of brick wall will not maintain its integrity unless it is properly supported by suitably designed load bearing brackets and restraint ties. In addition, the substrate may move differentially in relation to the cladding, so horizontal soft joints are required to keep the outer skin separate from the frame. Careful design and designation of fixing systems needs to be carried out in order to achieve stable facade installation.

FIX brickwork support systems are designed to be positioned at beam level and are fixed on to either anchor channels or on to concrete with expansion or chemical anchor bolts. When fixing is made with anchor channels, quick installation and horizontal adjustability is achieved which increases the rate of productivity.

The brickwork facade is planned according to the individual brickwork. There may be a lot of variations in terms of insulation thicknesses, cavity sizes, height of floor levels etc. Extensive design must be made for corners, lintels, joints as well as the straight facades. There are a wide range of brackets available for different executions.

A technical service is available for proposing fixing system after viewing the details of the project. The fixing system elements are available in stainless steel grade 1.4401 (A4) & 1.4301 (A2).

Various accessories are designed and produced in HAZ Metal to cover all aspects of the brickwork facade installation.

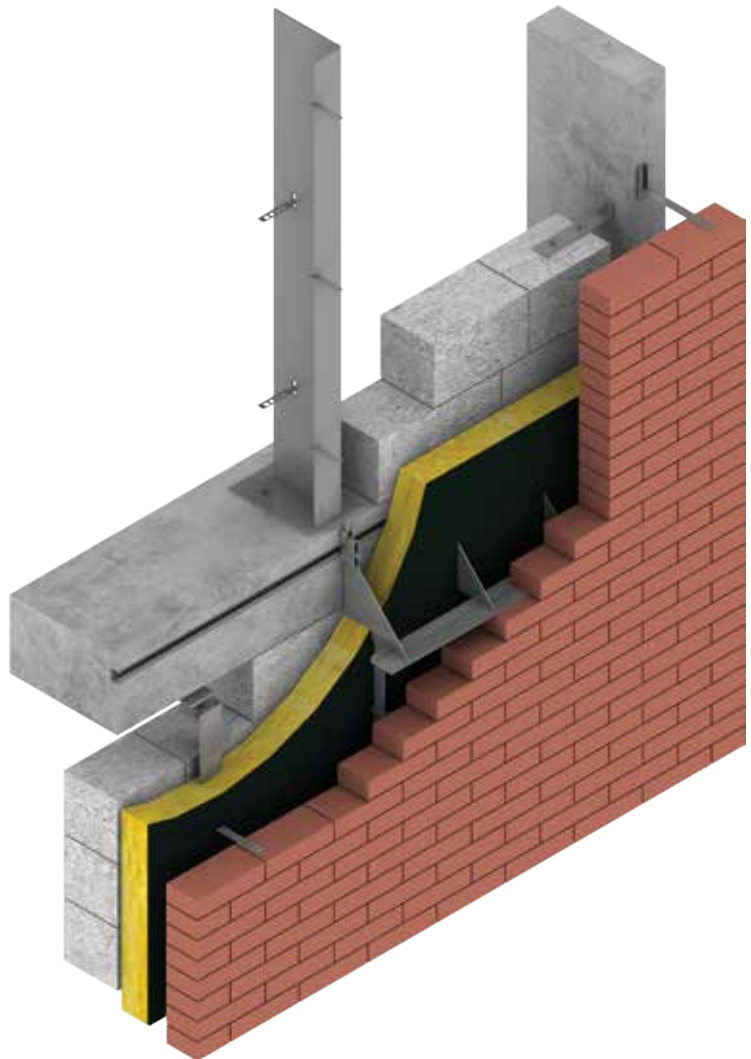

Application Variations

Single brickwork support bracket for the installation of bricks which are laid between two brackets. Fixing on to concrete made with anchor channels, anchor bolts or chemical bolts.

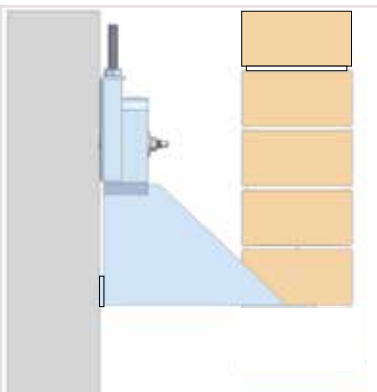

Brickwork support brackets with welded continuous L angles. Brick support is made along the length of the L angles.

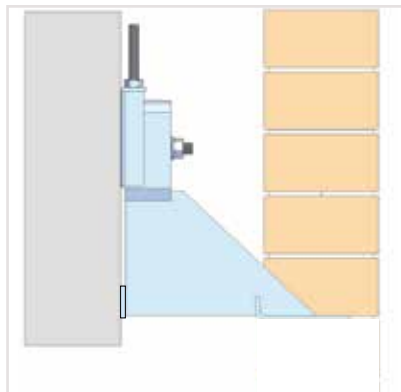

Brickwork support brackets with slot holed welded plates for installing prefabricated components. With cast in channels or u bolt inserts within the component, the fixing is made safely and easily.

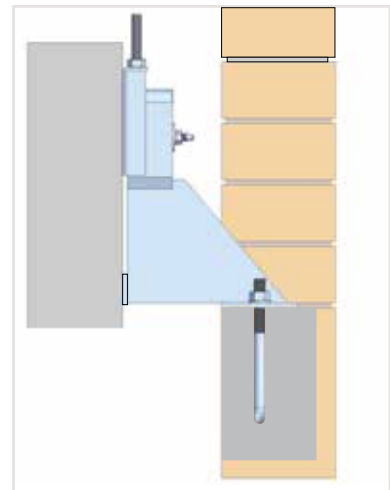

Brickwork Support Systems - Overview

Brickwork Facade

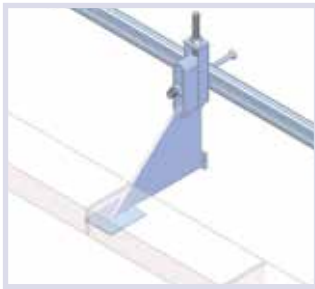

A brickwork facade built with brickwork is formed out of a load bearing inner wall, an insulating layer and an outer wall. The outer wall cannot be used for load bearing purposes nor can it be used for attachments of various components. The outer wall is a design element that satisfies the aesthetics and also serves as a means of weather protection. The outer wall which is constructed of layers of brickwork needs to be supported at regular intervals. The load of the brickwork is transferred on to the inner load bearing wall by brickwork support anchors. Restraining of the outer wall is made with restraint wall ties. Therefore, both the inner and outer wall shells are connected to each other with load bearing brackets and restraint wall ties.

Facade Design

The following points should be carefully evaluated when designing a brickwork facade.

- thickness of insulation and air gap,
- design of details, such as,
- wall areas,
- joints,
- external and internal corners,
- lintels above doors and windows,
- columns.

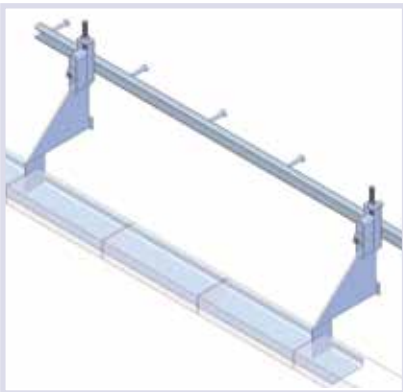

Many product variations are available for these situations, including the fixing of precast brickwork lintels and prefabricated elements.

The thickness of the insulation together with the air gap make up the dimension a for the distance between structural leaf and facing leaf. The greater the distance is between the two leaves, the larger has to be the projection K of the support brackets.

Brickwork support brackets are suitable for distances between leaves of 40 to 160 mm. The corresponding brickwork support brackets come with projections K of 130 to 350 mm. Angle supports are used for any cavity sizes that are less than 40 mm.

In order to cover all the loads within the application of brickworks installation, there are three load groups that the brackets can carry. The load categories are 3,5 kN, 7,0 kN and 10,5 kN.

The following standards are used in the design of brickwork support systems:

EN Eurocode 6	Design of brickwork structures
EN 1996-1	Rules for reinforced and unreinforced brickwork
DIN 1053	Design of brickworks facades

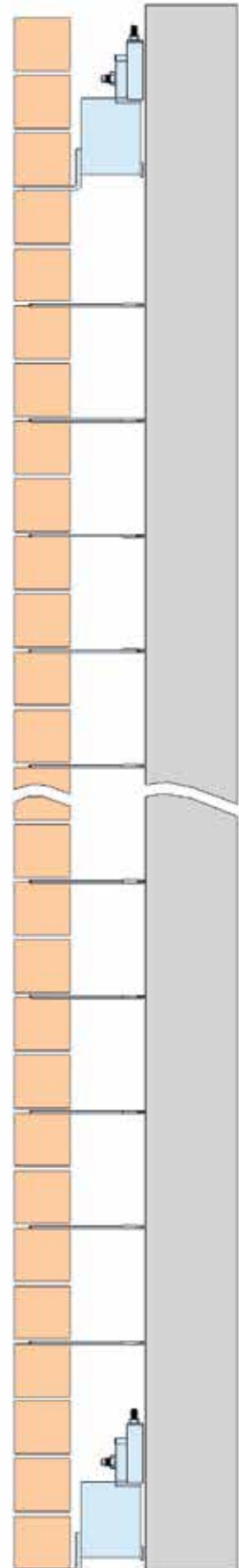
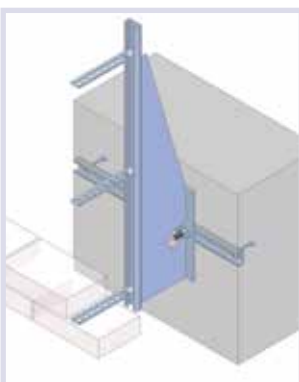
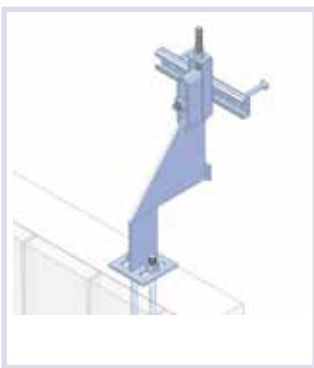

FIX Brickwork Support Systems - Design Principles

The brackets are available in three load categories. 3.5 kN, 7.0 kN and 10.5 kN. Projection sizes are available between 130 and 350 mm.

Anchoring positioning is calculated from the lower edge of the brickwork wall to be intercepted at x installation height. All brackets are adjustable in the vertical axis through the set screw from + / - 30 mms.

Fixing system design is formulated according to the utilisation rate, wall distance and the height of the facade.

The required connection types on to the walls are as follows.

Load category 3.5 kN: Anchor channel 38/17 or Expansion bolt M12 *

7.0 kN: Anchor channel 49/30 or Expansion bolt M12 *

10.5 kN: Anchor channel 54/33 or Expansion bolt M16 *

* The fastenings has to be calculated in each individual case

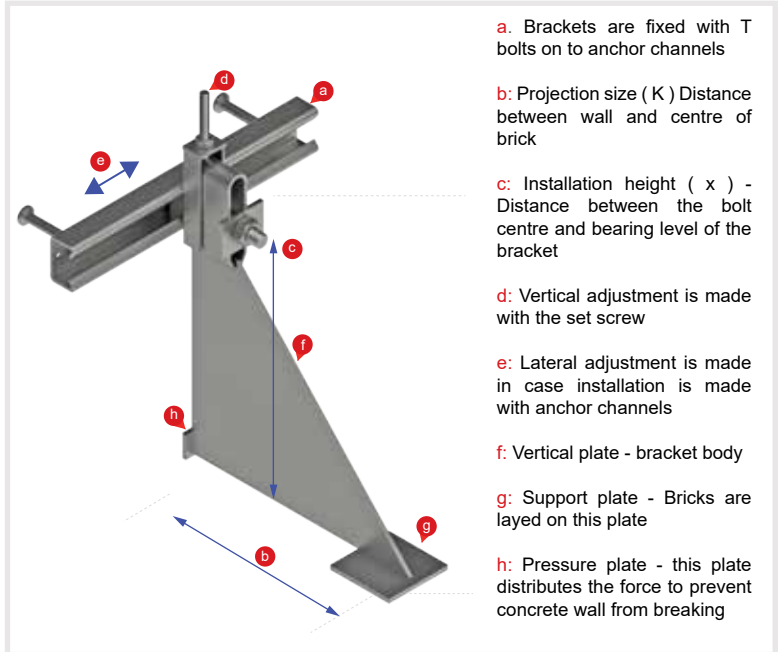

a. Brackets are fixed with T bolts on to anchor channels

b: Projection size (K) Distance between wall and centre of brick

c: Installation height (x) - Distance between the bolt centre and bearing level of the bracket

d: Vertical adjustment is made with the set screw

e: Lateral adjustment is made in case installation is made with anchor channels

f: Vertical plate - bracket body

g: Support plate - Bricks are layed on this plate

h: Pressure plate - this plate distributes the force to prevent concrete wall from breaking

Load Categories: There are three load categories and anchors are structurally designed to take the mentioned loads.

	Load Category	
	Allowable Load	Design Resistance
	3.5 kN	4.7 kN
	7.0 kN	9.5 kN
	10.5 kN	14.2 kN

Facade Height: Brickwork support brackets can take a maximum height of 12 metres depending on the thicknesses of the bricks. Generally brackets are fixed at floor levels to support the brickwork wall and restraining is done using restraint ties.

Projection Size: There are different projection sizes (K) that the brackets can accommodate. The standard projections are between 130 mm and 350 mm.

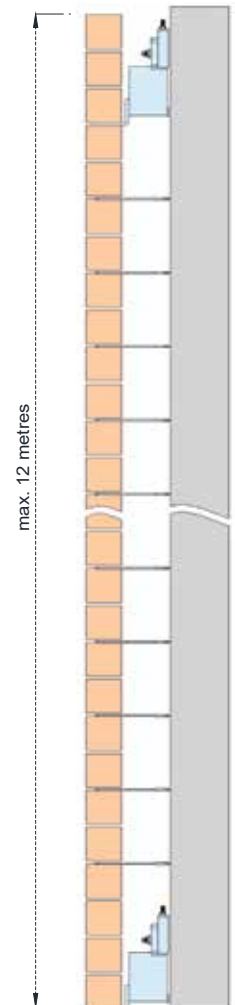
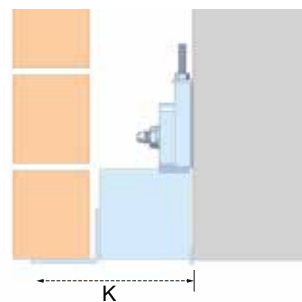

Vertical Adjustability: Adjustability in the vertical axis is made by swirling the set screw on top of the bracket. A total of 60 mm adjustability is possible.

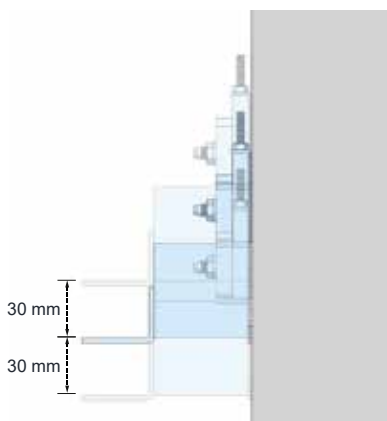

Load Bearing & Restraining: Support of the brickwork walls is made with load bearing brackets (T1). Restraining of the wall is made with restraint ties (T2)

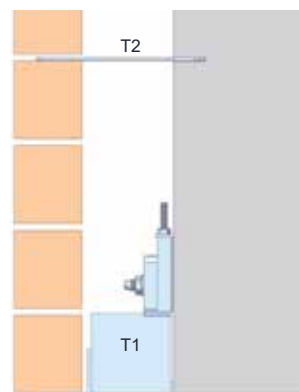

FIX Brickwork Support Systems - Design Principles

Load Calculation Principles

When determining the applied loads on the brickwork support brackets, the following principles need to be considered. The applied loads should be lower than the allowable loads.

$$\text{Applied loads (} F \text{) } \leq \text{ Allowable loads (all. } F \text{)}$$

When using the Eurocode standard the conversion from global safety factors to partial safety factors should be adopted. The acting loads should be factored by 1.4 to determine the Design loads.

$$\text{Design Effect Load (} F_{Ed} \text{) } \leq \text{ Design Resistance (} F_{Rd} \text{)}$$

The brickwork support anchors are available in the following load categories:

Allowable load:	Design resistance load:
3.5 kN	4.7 kN
7.0 kN	9.5 kN
10.5 kN	14.2 kN

Dead Load Calculation:

Dead Load (F_v) is important in order to choose the bracket with adequate load bearing capacity. Dead Load should be determined using the following formula: d_s is density which is considered to be 18 kN / m³ for bricks.

$$F_v = H * cs * bt * \gamma$$

(Loading height) * (Bolt spacing) * (Brick thickness) * (density)

$$F_{Ed} = F_v * 1.35$$

Resultant Load Calculation:

$$B = C + (d/3) + 15 \text{ mm}$$

$$M = F_v * x * B$$

$$Z = M / (x - x_u - 30 \text{ mm})$$

$$R = \sqrt{F_v^2 + F_h^2}$$

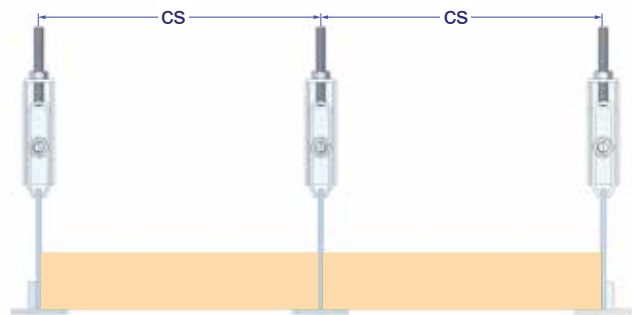
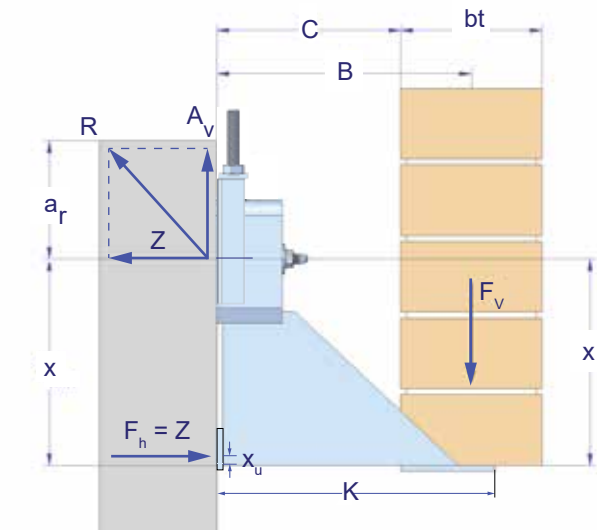
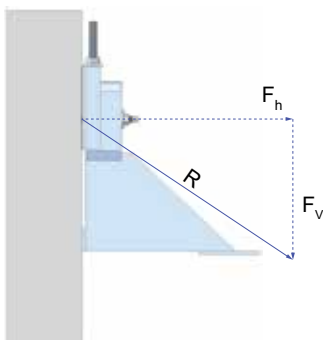

Legend

H:	Loading height	F_v:	Dead load
C:	Wall cavity	F_h:	Horizontal reaction load
K:	Projection	R:	Resultant load
B:	Lever (load distance) (C + (d/3)+15)		
bt:	Brick thickness		
cs:	Bolt spacing		
γ:	Density of bricks		

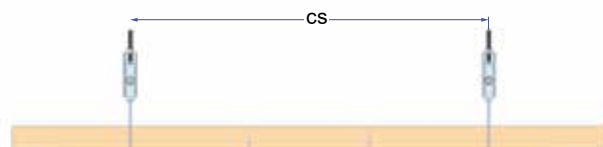
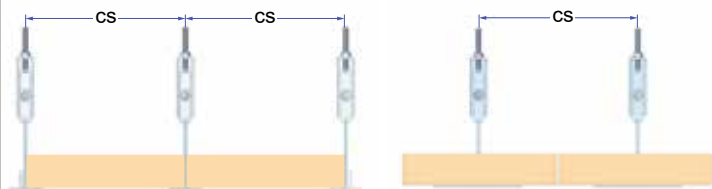

HMS Brickwork Support System - Design Principles

Restraining Of Facing Shell Brickwork Walls

Brick faced brickwork walls form a thin outer layer shell. This wall needs to be strengthened against buckling and must transfer wind loads into the load bearing walls. The brick shells are to be connected using restraining ties that are produced from stainless steel. The positioning of the restraining ties should be made according to the illustration on the right hand side. The vertical distance between the restraining ties should not exceed 500 mm. The horizontal distance between the ties should not exceed 750 mm.

Along the edges where there are free openings such as corners of buildings, expansion joints, window and door openings, and upper ends of external walls; three restraining ties should be used per metre of edge length in addition to the specifications provided. Restraint ties must absorb a tensile force of 1 kN with a slip of maximum 1 millimetre per tie.

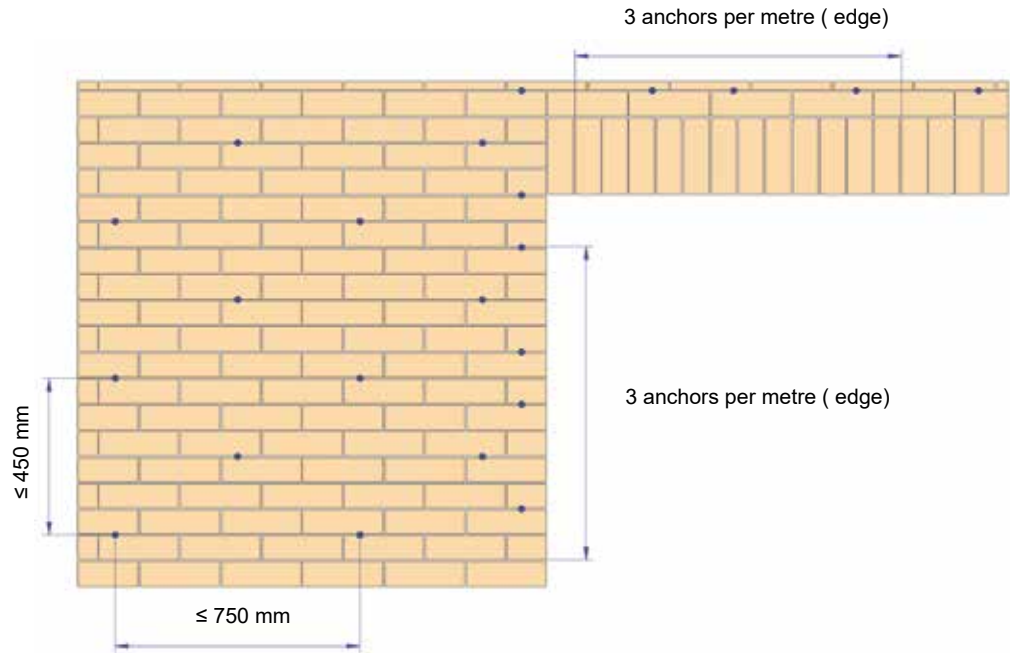

Minimum Quantity And Diameter Of Wire Anchors Per Square Meter

	Minimum quantity	Diameter
1. Wall area higher than 12 m above ground or cavity size from 70 to 120 mm	5	4
2. Cavity from 120 to 150 mm	7	4
3. Cavity from 120 to 150 mm	5	5
4. Cavity from 150 to 170 mm	8	5
5. Cavity from 170 to 200 mm	9	5

Bearing On The Support Brackets

When designing a non load bearing outer shell brickwork wall in front of a load bearing inner shell, the minimum thickness of the outer shell must be 90 mm. Thinner outer shell walls are classified as cladding and these claddings must be installed so that they are supported individually.

Outer brickwork shells can be supported with a maximum height of 12 metres. They may project up to 25 mm beyond their bearing structure. If the 115 mm thick outer shell is not higher than 2 floors then it may project up to one third of its width from its bearing.

Outer shells with thicknesses less than 115 mm must not be built to a height of more than 20 metres above ground and have to be supported in vertical intervals of about 6 metres.

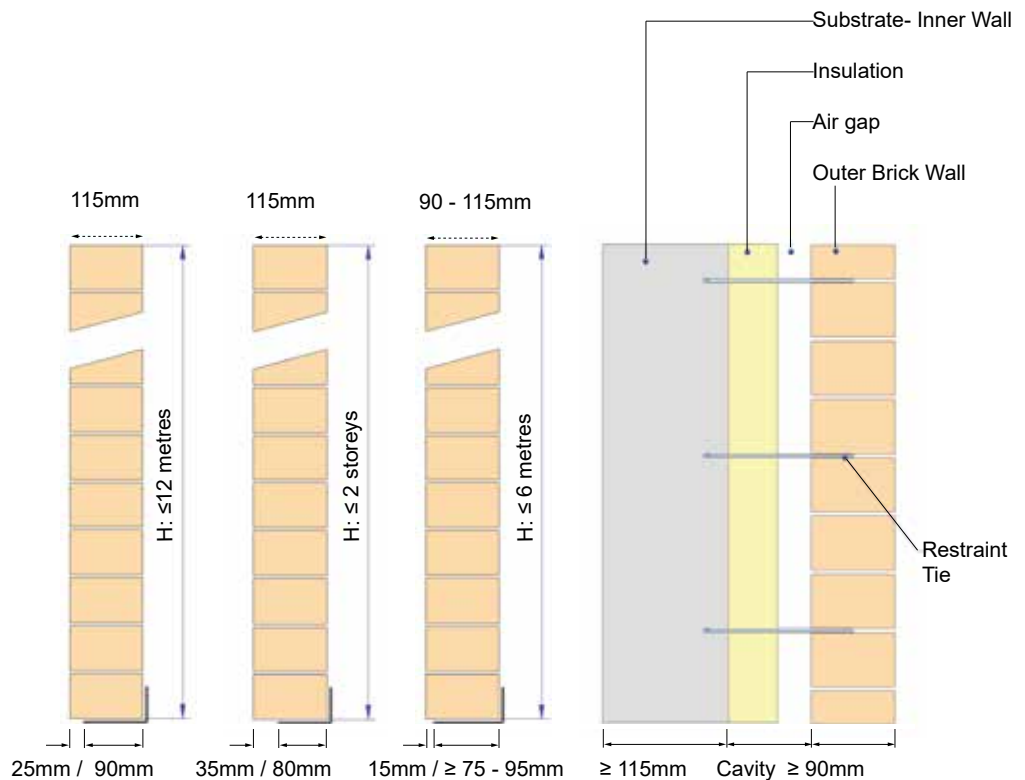

HMS Brickwork Support Systems - Design Principles

Layout And Design Of Expansion Joints

Fluctuations in temperature result in changes of lengths and volume of materials. There will also be movements on the building through the deflection of beams and columns. Expansion joints are incorporated on the facade in order to compensate for these movements to avoid any cracking of the brickwork facade.

Positioning Of Expansion Joints:

Horizontal joints are positioned at each supporting level. The distance between the support level thus the expansion joints are determined according to the maximum permissible height on to which the brickwork wall can be built. The distances between vertical expansion joints depend on climatic loads and the type of materials. The expansion joints in the brick facing shell must continue along the facing load bearing structure. The appearance choice of the expansion joints also is a factor that needs to be taken into consideration. Some examples of the expansion joint positioning are shown in the figures on the right.

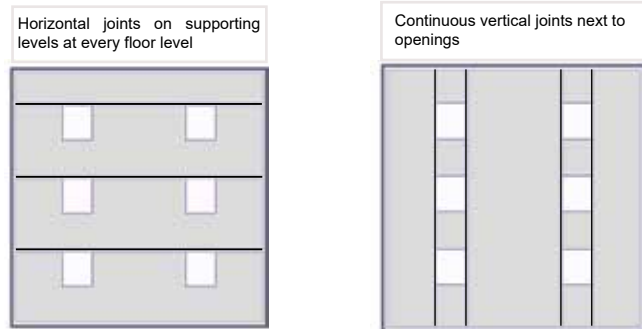

Vertical And Horizontal Joint Details:

Expansion joints should be placed in the outer shell of the brick wall. The distances of the expansion joints depend on various factors such as temperature, humidity, the type of materials used, height of the building, type of the load bearing walls etc. The expansion joints should take the movements of the building structure as well as the thermal expansion of the cladding material. Free mobility of the outer shell must be enabled in order to avoid cracking of the brick work. The expansion joints should be filled with suitable material and must be tightly sealed. The structure of the expansion joints should be as shown below:

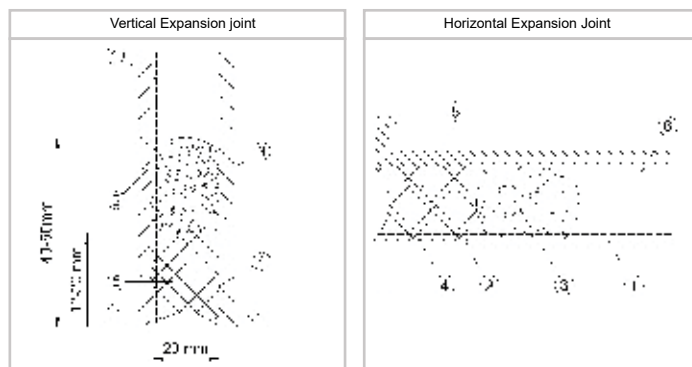

Details:

1. Compressed joint. 2. Elongated joint. 3. Joint gasket.
4. Keyed surface. 5. Joint sealant. 6. Bracket.

Expansion Joint Arrangement:

The distance between the vertical expansion joints depends on the climate conditions of the geographical area in which the construction will be made. In general, the connected brickwork walls should not be built wider than 7-14 metres in the corner areas. The wall slabs can be interrupted with a vertical joint or continue around the corner as shown in the diagram on the right.

Thermal expansion coefficient	
Clay bricks	0.006 mm / m K
Calcium silicate blocks	0.008 mm / m K
Gas concrete	0.008 mm / m K
Concrete	0.012 mm / m K
Steel	0.012 mm / m K

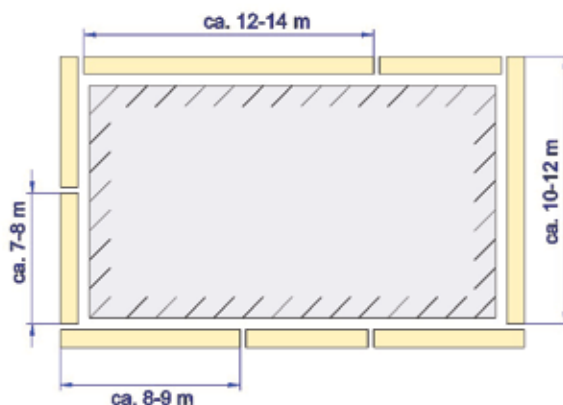

FIX Brickwork Support Brackets - Introduction

FIX Brickwork support brackets are adjustable and secure brackets that are designed for the easy and quick installation of brick facing walls.

FIX support brackets are user friendly and are combined with a patented adjustable profile part that is assembled in the top of the bracket body. The brackets can be mounted by one single person. During the installation no loose parts fall down and the installer always has a hand free for adjusting.

When the **FIX** brickwork brackets are fixed on to walls, the vertical adjustability of the brackets is made by the set screw and nut. There is an adjustability space of 60 mm. The **FIX** brickwork anchors are installed either with expansion bolts or T head bolts into channels.

There are various type of **FIX** anchors that can be used for different applications.



EN 845-1



• Perspective picture of brick facing installation with **FIX-U** brackets.

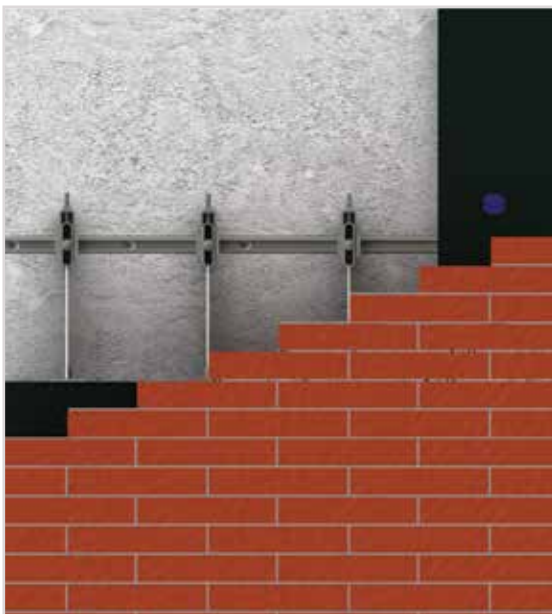

• Elevation picture of brick facing installation with **FIX-U** brackets

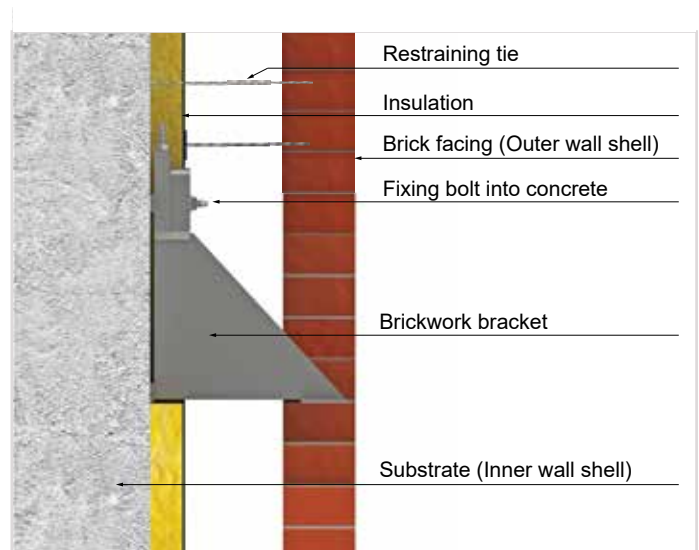

• Section picture of brick facing wall

Brickwork Fixing Systems - Product Range

The production of various types of brickwork support systems is available at HAZ Metal. There is a standard product range shown below. Special parts can be produced according to project requirements. Materials used are stainless steel and galvanized mild steel. Brickwork support anchors are produced from stainless steel 1.4301 (AISI 304) & 1.4401 (AISI 316).

Load Bearing Brackets

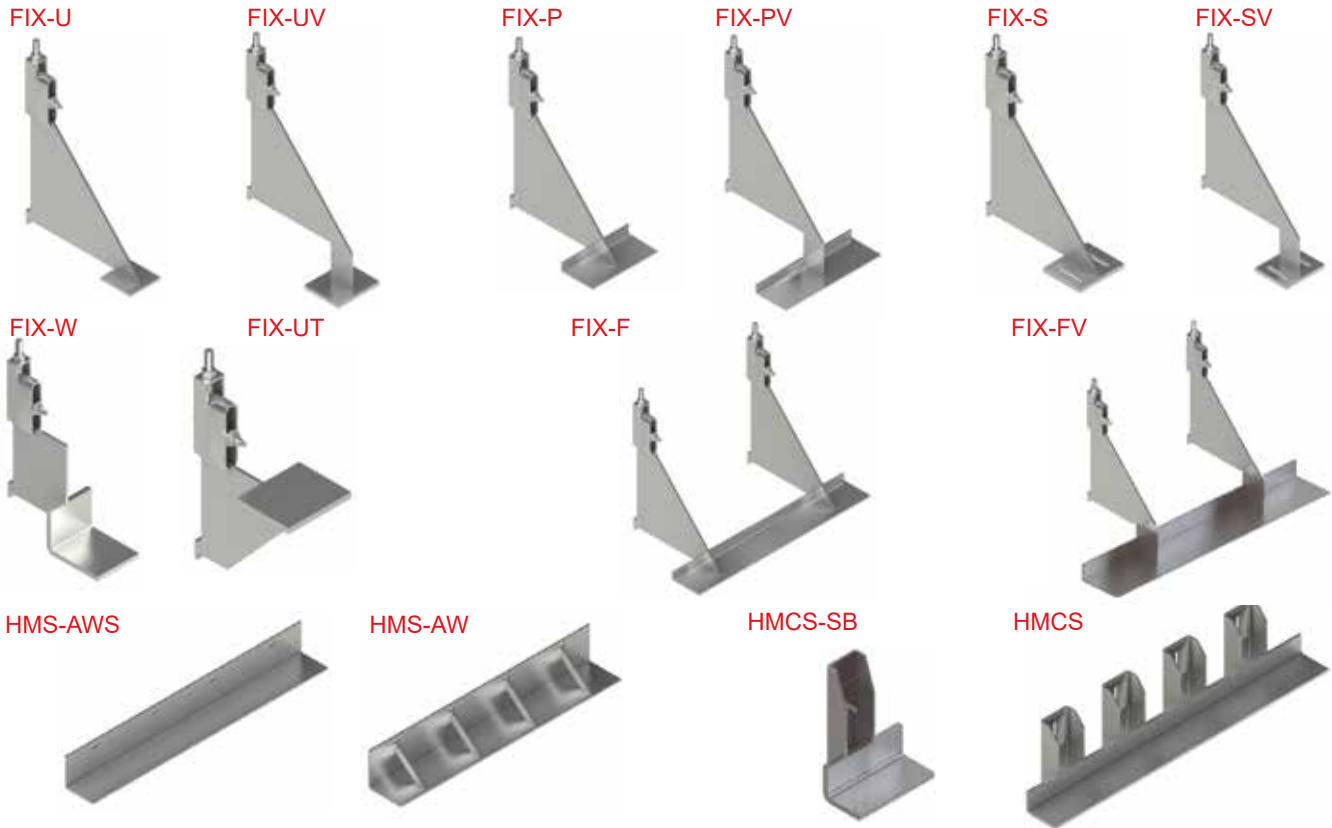

Accessories



Wall Restraining Ties

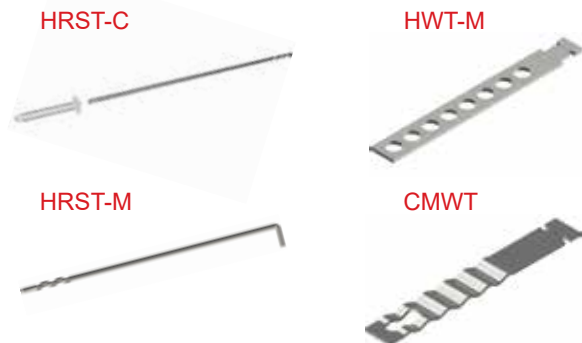

Windpost Restraints



Lintel Supports

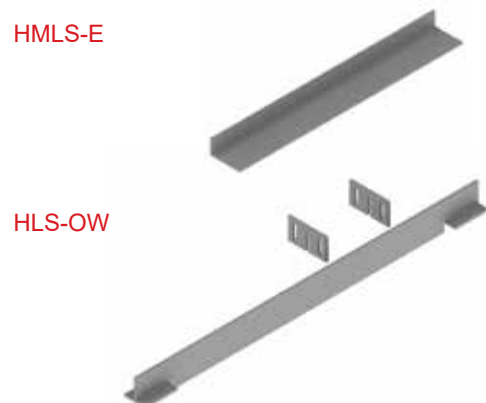

FIX-U Support Bracket - Product Details

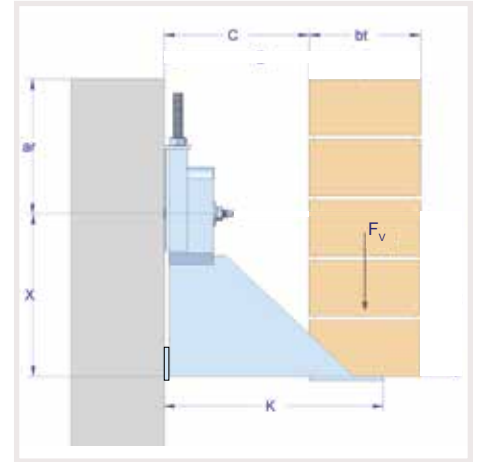
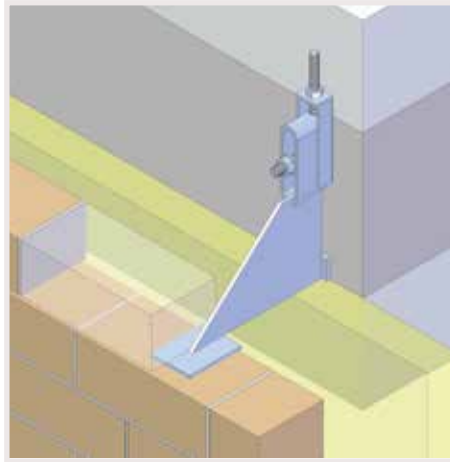

Cavity a (mm)	Load Category 3,5 kN FRd = 4,7 kN		Load Category 7,0 kN FRd = 9,5 kN		Load Category 10,5 kN FRd = 14,2 kN	
	Projection K (mm)	x size (mm)	Projection K (mm)	x size (mm)	Projection K (mm)	x size (mm)
60 ± 15	150	150	150	200	150	250
80 ± 15	170	150	170	200	170	250
100 ± 15	190	150	190	200	190	250
120 ± 15	210	150	210	200	210	250
140 ± 15	230	175	230	250	230	300
160 ± 15	250	175	250	250	250	300
180 ± 15	270	200	270	270	270	320
200 ± 15	290	200	290	290	290	340
220 ± 15	310	220	310	310	310	360
240 ± 15	330	240	330	330	330	380
260 ± 15	350	260	350	350	350	400

Anchor bolt	HB03 M12x145	HB03 M12x145	HB03 M16x185
	HB07 M12x190	HB07 M12x190	HB07 M16x210
Anchor channel	HMPR 38/17 with T head bolt M12x80	HMPR 49/30 with T head bolt M16x100	HMPR 54/33 with T head bolt M16x100

- Specified load-bearing capacities refer to fixings in concrete \geq C20/25
- Material : Stainless Steel 1.4301 (A2) & 1.4401 (A4)
- Expansion bolts and anchor channels are provided separately
- Structural calculation reports are available upon order
- The fastenings have to be calculated for each individual case

Distance between supports	Angle Length L (mm)	c (mm)	s (mm)
500	480	30	2
750	730	30	3
1000	980	40	4

HMLS Angle

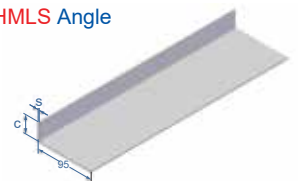

FIX-U Brickwork Support Bracket

This brickwork support bracket is with a single welded plate used for independent installation of each brick block. This bracket is used for closed surface elevation brick cladding.

Product Code Description

FIX-U - 3,5 / 150

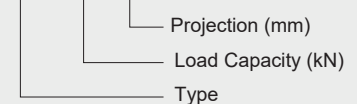

FIX Support Brackets - Single Bracket Load table with Angle support

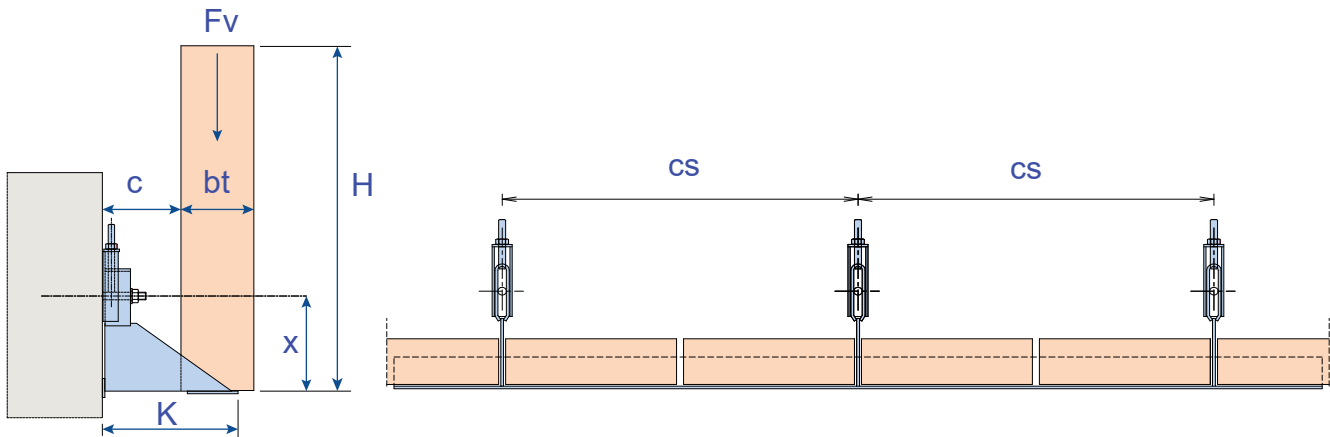

Load Height H (m)	CS = 250mm	CS = 500 mm	CS = 750 mm	CS = 1000 mm	Load Category
H (m)	Fv (kN)	Fv (N)	Fv (kN)	Fv (kN)	
12	6,2	12,4			
11	5,7	11,4			
10	5,2	10,4			
9	4,7	9,3	14,0		
8	4,1	8,3	12,4		
7	3,6	7,2	10,9		
6	3,1	6,2	9,3	12,4	14,0
5	2,6	5,2	7,8	10,4	10,5
4	2,1	4,1	6,2	8,3	
3	1,6	3,1	4,7	6,2	7,0
2	1,0	2,1	3,1	4,1	
1	0,5	1,0	1,6	2,1	3,5

- Load category 14,0 kN and over is available with special design. Alternatively HMCS brick work supports can be used.
- Load capacity of the brackets are verified by structural calculations. Approvals are subject to application.

Brackets Load Transfer Values

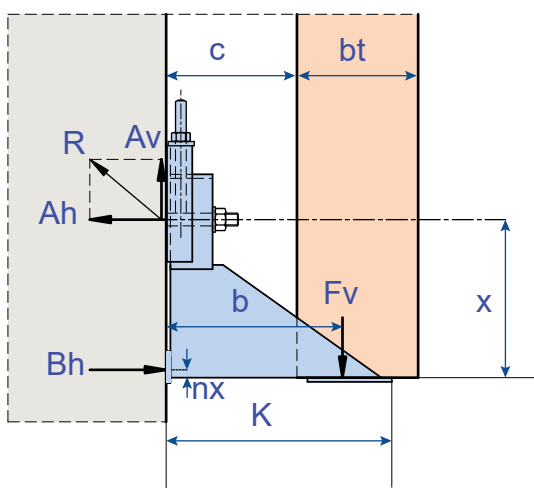

$B_h = A_h$
 $A_v = F_v$

Maximum Transfer Loads - Ah & R for full Bracket load capacity									
a (mm)	x (mm)	Fv = 3,5 kN		Fv = 7,0 kN			Fv = 10,5 kN		
		Ah (kN)	R (kN)	x (mm)	Z (kN)	R (kN)	x (mm)	Z (kN)	R (kN)
60	150	3,60	5,02	200	4,96	8,58	250	5,67	11,93
80	150	4,24	5,50	200	5,83	9,11	250	6,67	12,44
100	150	4,88	6,00	200	6,71	9,70	250	7,67	13,00
120	150	5,51	6,53	200	7,58	10,32	250	8,67	13,61
140	175	5,01	6,11	250	6,44	9,51	300	7,81	13,08
160	175	5,53	6,54	250	7,11	9,98	300	8,61	13,58
180	200	5,10	6,19	300	6,28	9,40	350	8,00	13,14
200	200	5,54	6,55	300	6,82	9,77	350	8,58	13,56
220	220	5,31	6,36	310	7,08	9,97	360	8,97	13,81
240	240	5,13	6,21	330	7,08	9,96	380	9,06	13,87
260	260	4,98	6,10	350	7,08	9,95	400	9,14	13,92

- The maximum load transfer values are applicable for cases where vertical adjustability is at 30 mm and for brick wall thickness of 11.5 cm

FIX Support Brackets - Application Guide

FIX-U Support Bracket

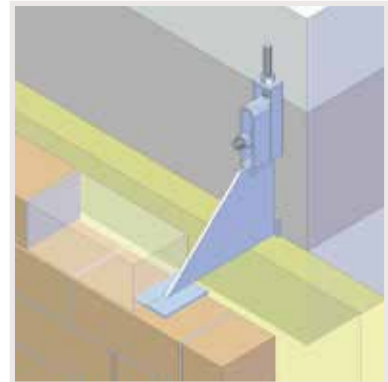
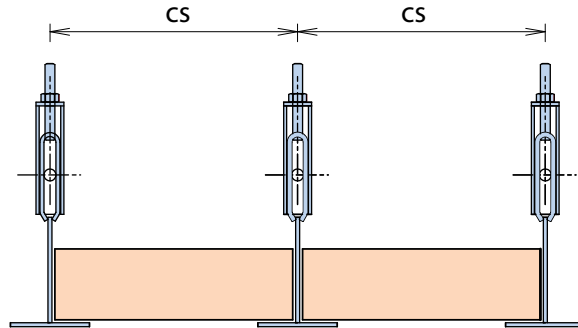

- Single bracket with welded support plate
- This brickwork support bracket is used for independent installation of each brick block
- This bracket is used for closed surface elevation brick cladding
- The offset level plate height distance can be designed according to the application requirement

FIX-UV Support Bracket

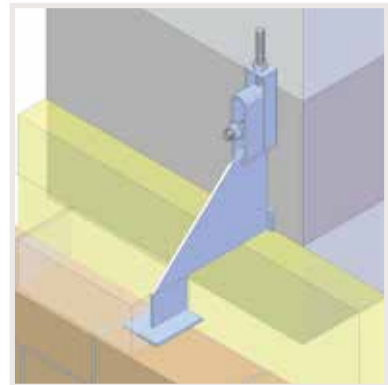
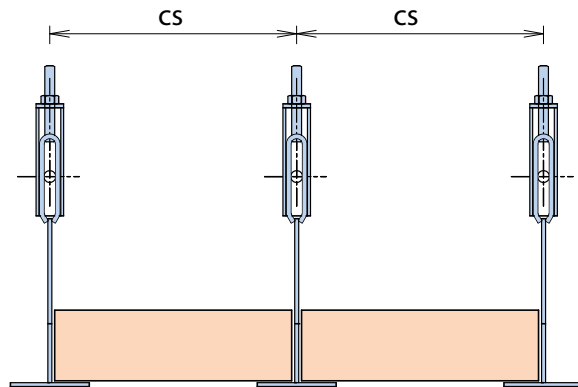

- Single bracket with welded support plate and an offset supporting level plate
- The offset level plate height distance can be designed according to the application requirement
- Used for installing at lower level support than the fixing level on the substrate, such as over openings

FIX-UT Support Bracket

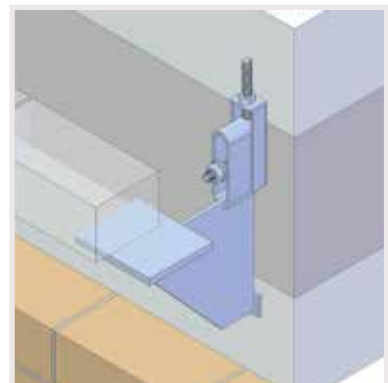
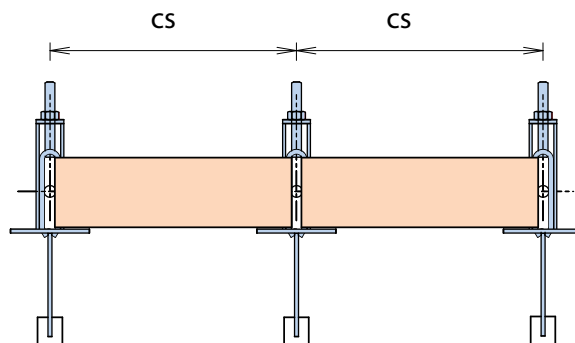

- Single bracket with welded high set support plate
- Used for installing bricks at high joint level

FIX Support Brackets - Application Guide

FIX-W Support Bracket

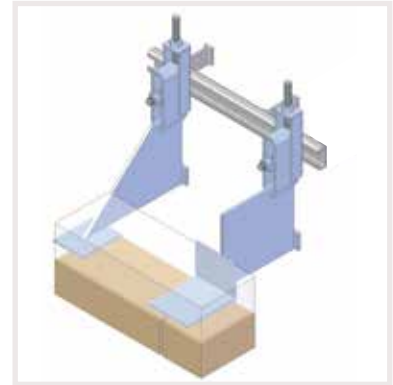
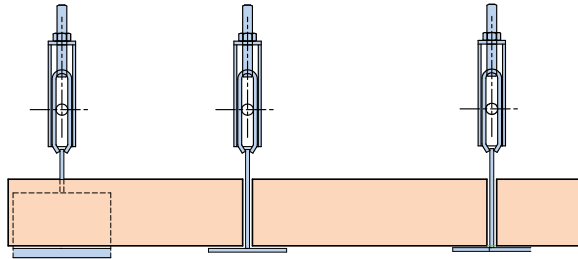

- Single bracket with welded L shaped support plate
- This type of brickwork support bracket is used in areas such as edges, corners and where there are expansion joints
- The welded L shaped support plate can be designed according to application details

FIX-WV Support Bracket

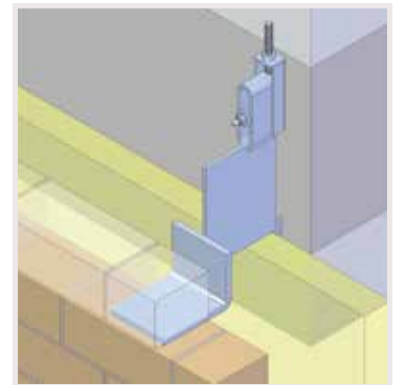
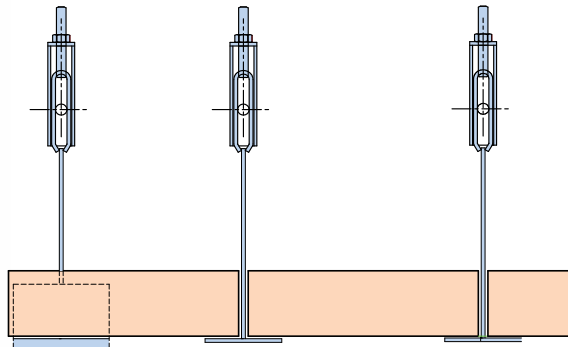

- This support bracket has the same properties as the **FIX-W** bracket with a higher offset level distance
- The offset level height distance can be designed according to the application requirement
- Used for installing at lower level support than the fixing level on the substrate, such as over openings

FIX-V Support Bracket positioning

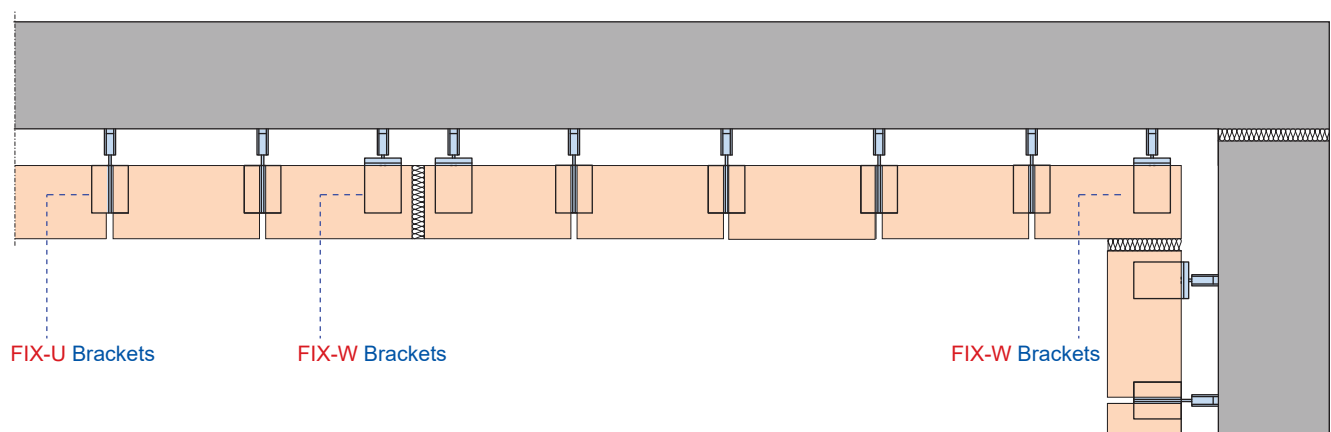

FIX Support Brackets - Application Guide

FIX-P Support Bracket

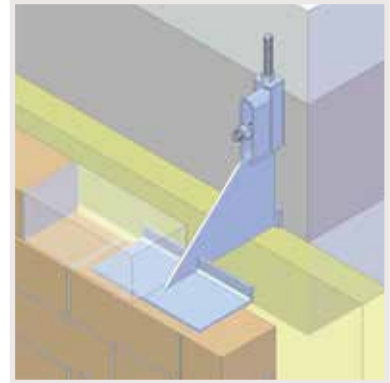
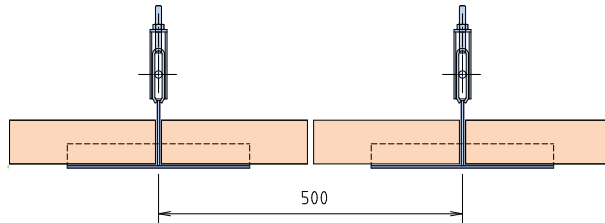

- Single bracket with welded short angle
- The angle can be dimensioned according to the application details
- Preferably used for installing bricks in wall edge situations, where two bricks can be supported with a single bracket

FIX-PV Support Bracket

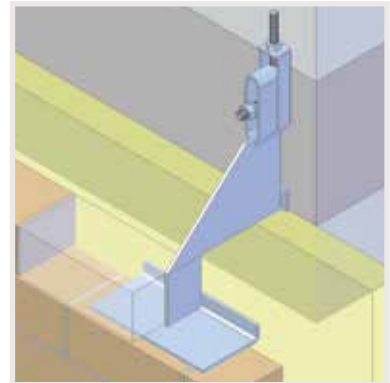
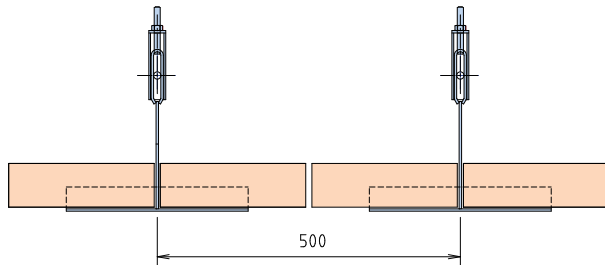

- Single bracket with welded short angle and an offset support level plate
- The angle and the offset plate can be dimensioned according to the application details
- Used for installing at lower level support than the fixing level on the substrate, such as over openings

FIX-P Support Bracket positioning

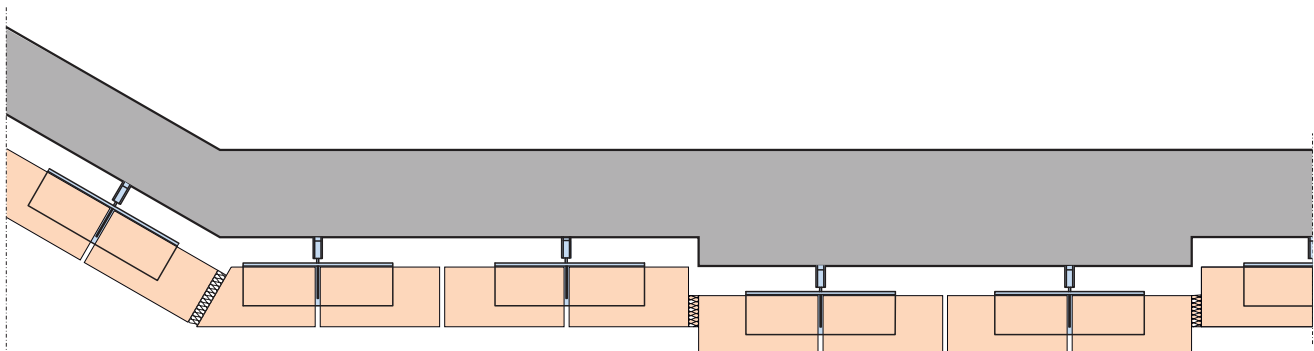

FIX Support Brackets - Application Guide

FIX-S Support Bracket

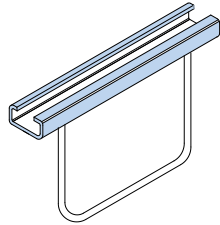

Anchor channel with welded bar

- Single bracket with welded plates with slotted holes
- This bracket is used for supporting precast lintels above openings which do not have bearings at the sides
- Supports are connected to the anchor channels or loops are inserted in the lintels

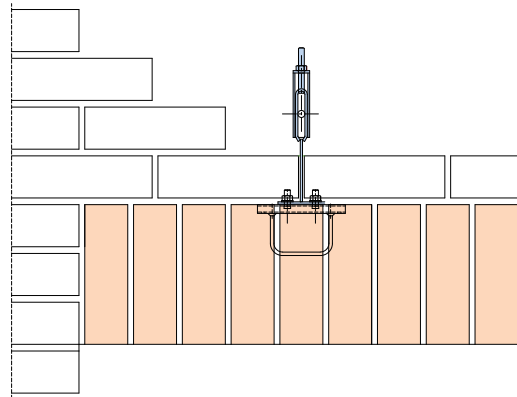
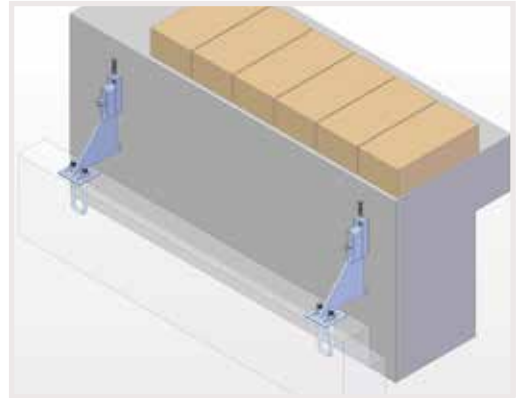

FIX-SV Support Bracket

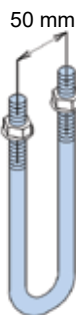

U shaped loop insert

- Single bracket with welded plates with slot holes and an offset level plate
- This bracket is used to support lintels where the support offset level is lower than the fixing level on the substrate
- The offset level plate height distance can be designed according to the application details

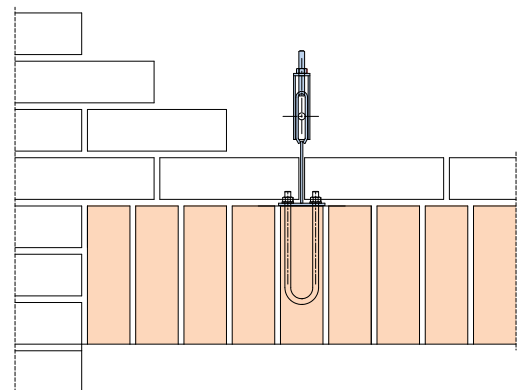
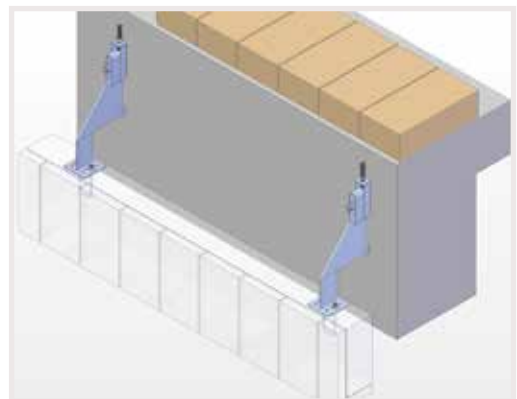

FIX Support Brackets - Product Information

FIX-F Support Bracket

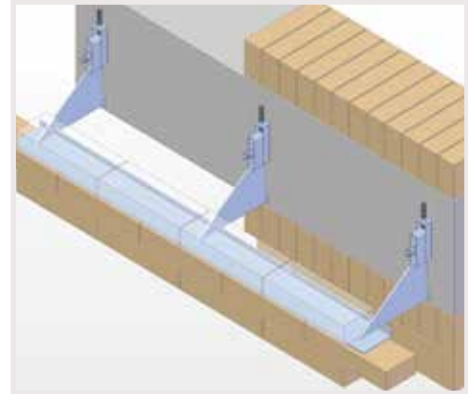

- These brackets are combined supporting brackets with a continuous supporting angle welded on to two or more bracket backs
- They are used to support visible or hidden openings in buildings or outside corners with or without vertical joints
- Available in lengths of multiples of 250 mm with up to three welded bracket backs

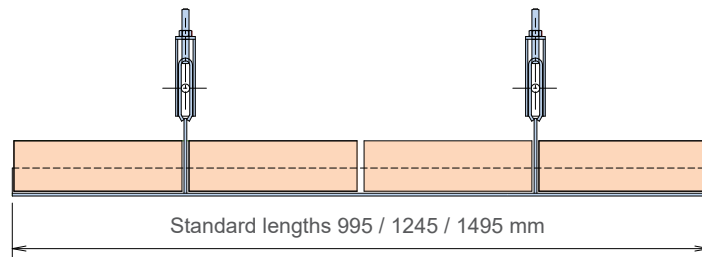

FIX-FV Support Bracket

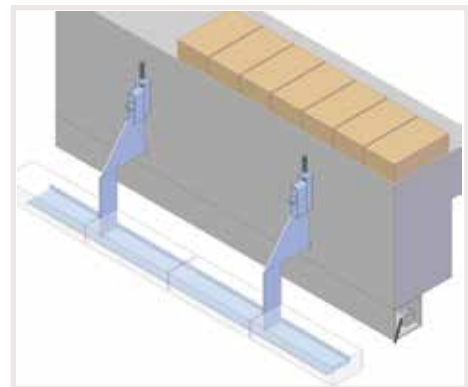

- This continuous support bracket has the same properties as the FIX-F type support, with an additional welded offset level plate
- The use of this bracket is necessary where the support offset level is lower than the level of fixing on the substrate

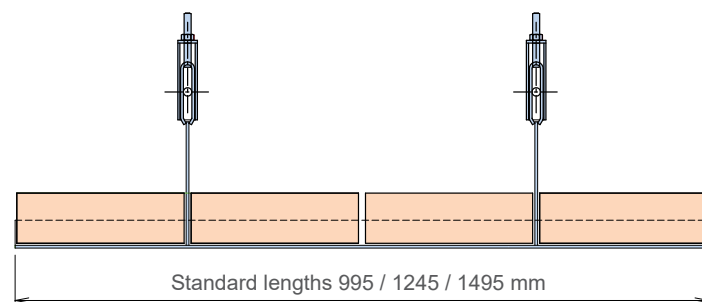

FIX Support Brackets - Product Information

FIX-FSC Support Bracket

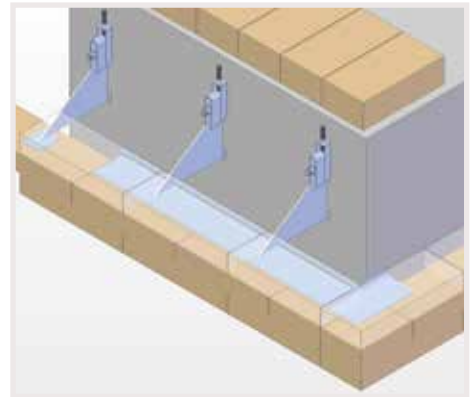

- These brackets are continuous supporting angles with a welded corner part at one end of the angle
- This support bracket is used to allow easy and secure installation of bricks at corner turns

FIX-FDC Support Bracket

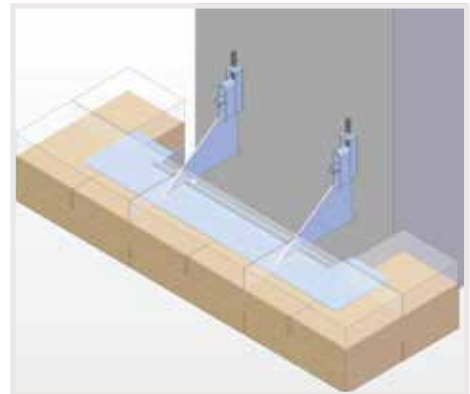

- These brackets are continuous supporting angles with a welded corner part at both ends of the angle
- This support bracket is used to allow easy and secure installation of bricks on to columns

FIX-FSC Support Bracket positioning

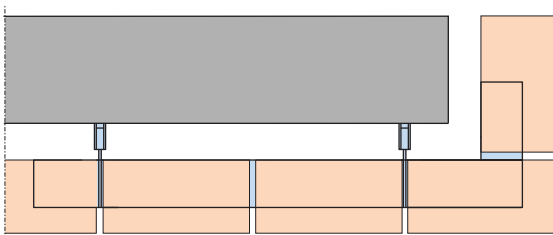

FIX-FDC Support Bracket positioning

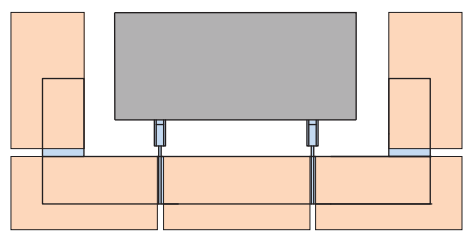

FIX-U Support Bracket - Product Details



- 1 - Bracket body
- 2 - Thermal break
- 3 - Threaded rod
- 4 - Adjustable profile
- 5 - Anchor bolt
- 6 - Support plate
- 7 - Welded pressure plate

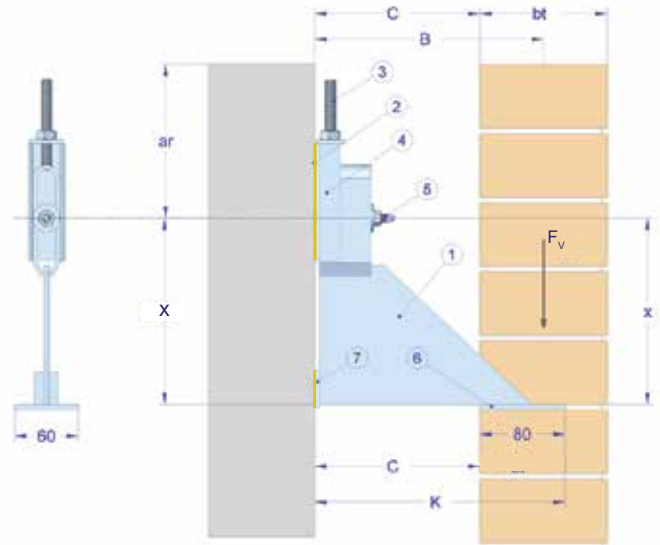

Product Code	Technical Details					
	Projection +/- 15 mm	Load Range	Cavity +/- 15 mm	X size	Bolt Size ¹⁾	Cast-in Channel T Head Bolt ¹⁾
	K (mm)	F _v (kN)	C (mm)	X (mm)	E.b. (mm)	CI (mm)
FIX-U-3,5/150	150	3,5	60	150	M12x145	38/17 - M12x80
FIX-U-3,5/170	170		80	150		
FIX-U-3,5/190	190		100	150		
FIX-U-3,5/210	210		120	150		
FIX-U-3,5/230	230		140	175		
FIX-U-3,5/250	250		160	175		
FIX-U-3,5/270	270		180	200		
FIX-U-3,5/290	290		200	200		
FIX-U-3,5/310	310		220	220		
FIX-U-3,5/330	330		240	240		
FIX-U-3,5/350	350		260	260		
FIX-U-7,0/150	150	7,0	60	200	M12x145	49/30 - M16x100
FIX-U-7,0/170	170		80	200		
FIX-U-7,0/190	190		100	200		
FIX-U-7,0/210	210		120	200		
FIX-U-7,0/230	230		140	250		
FIX-U-7,0/250	250		160	250		
FIX-U-7,0/270	270		180	270		
FIX-U-7,0/290	290		200	290		
FIX-U-7,0/310	310		220	310		
FIX-U-7,0/330	330		240	330		
FIX-U-7,0/350	350		260	350		
FIX-U-10,5/150	150	10,5	60	250	M16x185	54/33 - M16x100
FIX-U-10,5/170	170		80	250		
FIX-U-10,5/190	190		100	250		
FIX-U-10,5/210	210		120	250		
FIX-U-10,5/230	230		140	300		
FIX-U-10,5/250	250		160	300		
FIX-U-10,5/270	270		180	350		
FIX-U-10,5/290	290		200	350		
FIX-U-10,5/310	310		220	360		
FIX-U-10,5/330	330		240	380		
FIX-U-10,5/350	350		260	400		

- Material : Stainless Steel 1.4301 (AISI 304-A2) & 1.4401 (AISI 316-A4) • Load capacities refer to fixings in concrete ≥ C20/25 • Loads stated are allowable loads
- Other sizes are available for production upon request • Bolts and channels are provided separately • Structural calculation reports are available upon order
- The fastenings has to be calculated for each individual case

FIX-U Support Bracket

This brickwork support bracket is manufactured with a single welded plate which is used for installation of each brick block independently. The FIX-U brickwork support bracket is used for straight and curved elevation brick installation.

Product Code Description

FIX-U - 3,5 / 150

- Projection (mm)
- Dead Load (kN)
- Type

FIX-UV Support Bracket - Product Details



- 1 - Bracket body
- 2 - Thermal break
- 3 - Threaded rod
- 4 - Adjustable profile
- 5 - Anchor bolt
- 6 - Support plate
- 7 - Welded pressure plate
- 8 - Extension plate

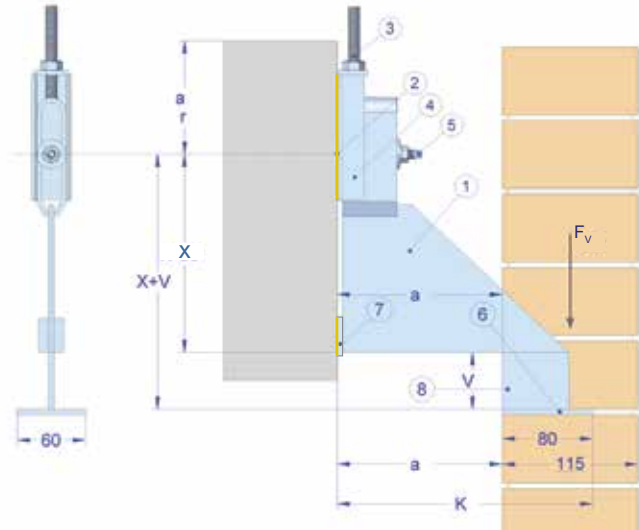

Product Code	Technical Details						
	Projection +/- 15 mm	Load Range	Cavity +/- 15 mm	x size	Bolt Size ¹⁾	Cast-in Channel ¹⁾	Welded Extension Plate
	K (mm)	F _v (kN)	C (mm)	x (mm)	E.b. (mm)	Cl (mm)	V (mm)
FIX-UV-3,5/150	150	3,5	60	150	M12x145	38/17 - M12x80	Determined according to application detail
FIX-UV-3,5/170	170		80	150			
FIX-UV-3,5/190	190		100	150			
FIX-UV-3,5/210	210		120	150			
FIX-UV-3,5/230	230		140	175			
FIX-UV-3,5/250	250		160	175			
FIX-UV-3,5/270	270		180	200			
FIX-UV-3,5/290	290		200	200			
FIX-UV-3,5/310	310		220	220			
FIX-UV-3,5/330	330		240	240			
FIX-UV-3,5/350	350	260	260				
FIX-UV-7,0/150	150	7,0	60	200	M12x145	49/30 - M16x100	Determined according to application detail
FIX-UV-7,0/170	170		80	200			
FIX-UV-7,0/190	190		100	200			
FIX-UV-7,0/210	210		120	200			
FIX-UV-7,0/230	230		140	250			
FIX-UV-7,0/250	250		160	250			
FIX-UV-7,0/270	270		180	270			
FIX-UV-7,0/290	290		200	290			
FIX-UV-7,0/310	310		220	310			
FIX-UV-7,0/330	330		240	330			
FIX-UV-7,0/350	350	260	350				
FIX-UV-10,5/150	150	10,5	60	250	M16x185	54/33 - M16x100	Determined according to application detail
FIX-UV-10,5/170	170		80	250			
FIX-UV-10,5/190	190		100	250			
FIX-UV-10,5/210	210		120	250			
FIX-UV-10,5/230	230		140	300			
FIX-UV-10,5/250	250		160	300			
FIX-UV-10,5/270	270		180	350			
FIX-UV-10,5/290	290		200	350			
FIX-UV-10,5/310	310		220	360			
FIX-UV-10,5/330	330		240	380			
FIX-UV-10,5/350	350	260	400				

• Material : Stainless Steel 1.4301 (AISI 304-A2) & 1.4401 (AISI 316-A4) • Load capacities refer to fixings in concrete ≥ C20/25 • Loads stated are allowable loads
 • Other sizes are available for production upon request • Bolts and channels are provided separately • Structural calculation reports are available upon order
 • The fastenings has to be calculated for each individual case

FIX-UV support bracket

This brickwork support bracket is used for installing brick above window and door opening. An extension plate is welded on to the bracket body in order to reach down to desired position of fixing. The extension plate labeled as V on the table above can be produced in the required size to fit the application.

Product Code Description

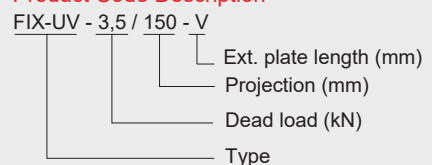

FIX-P Support Bracket - Product Details

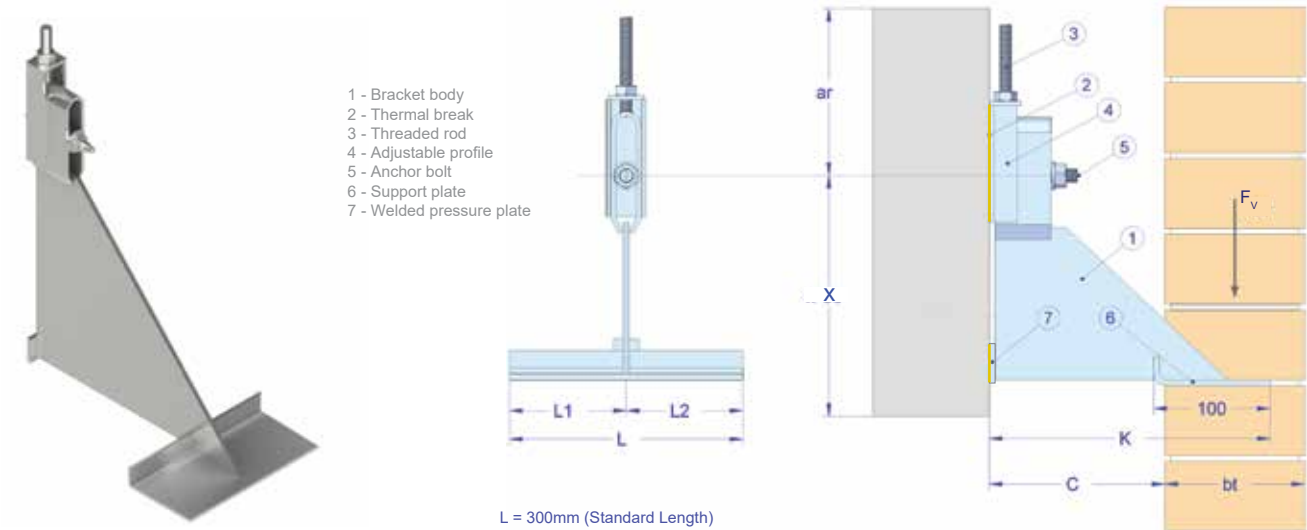

Product Code	Technical Details						
	Projection +/- 15 mm	Load Range	Cavity +/- 15 mm	x size	Bolt Size ¹⁾	Cast-in Channel ¹⁾	Welded Support Plate
	K (mm)	F _v (kN)	C (mm)	x (mm)	E.b. (mm)	CI (mm)	L1/L2 (mm)
FIX-P-3,5/150	150	3,5	60	150	M12x145	38/17 - M12x80	Determined according to application detail
FIX-P-3,5/170	170		80	150			
FIX-P-3,5/190	190		100	150			
FIX-P-3,5/210	210		120	150			
FIX-P-3,5/230	230		140	175			
FIX-P-3,5/250	250		160	175			
FIX-P-3,5/270	270		180	200			
FIX-P-3,5/290	290		200	200			
FIX-P-3,5/310	310		220	220			
FIX-P-3,5/330	330		240	240			
FIX-P-3,5/350	350		260	260			
FIX-P-7,0/150	150		7,0	60			
FIX-P-7,0/170	170	80		200			
FIX-P-7,0/190	190	100		200			
FIX-P-7,0/210	210	120		200			
FIX-P-7,0/230	230	140		230			
FIX-P-7,0/250	250	160		250			
FIX-P-7,0/270	270	180		270			
FIX-P-7,0/290	290	200		290			
FIX-P-7,0/310	310	220		310			
FIX-P-7,0/330	330	240		330			
FIX-P-7,0/350	350	260		350			
FIX-P-10,5/150	150	10,5		60	250	M16x185	54/33 - M16x100
FIX-P-10,5/170	170		80	250			
FIX-P-10,5/190	190		100	250			
FIX-P-10,5/210	210		120	250			
FIX-P-10,5/230	230		140	300			
FIX-P-10,5/250	250		160	300			
FIX-P-10,5/270	270		180	340			
FIX-P-10,5/290	290		200	350			
FIX-P-10,5/310	310		220	360			
FIX-P-10,5/330	330		240	380			
FIX-P-10,5/350	350		260	400			

- Material : Stainless Steel 1.4301 (AISI 304-A2) & 1.4401 (AISI 316-A4) • Load capacities refer to fixings in concrete ≥ C20/25 • Loads stated are allowable loads
- Other sizes are available for production upon request • Bolts and channels are provided separately • Structural calculation reports are available upon order
- The fastenings has to be calculated for each individual case

FIX-P Support Bracket

This type of brickwork support bracket has a wide welded support plate for more secure positioning of the brick blocks. The width of the welded support is determined according to the application detail.

Product Code Description

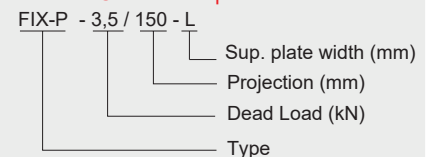

FIX-PV Support Bracket - Product Details



- 1 - Bracket body
- 2 - Thermal break
- 3 - Threaded rod
- 4 - Adjustable profile
- 5 - Anchor bolt
- 6 - Support plate
- 7 - Welded pressure plate
- 8 - Extension plate

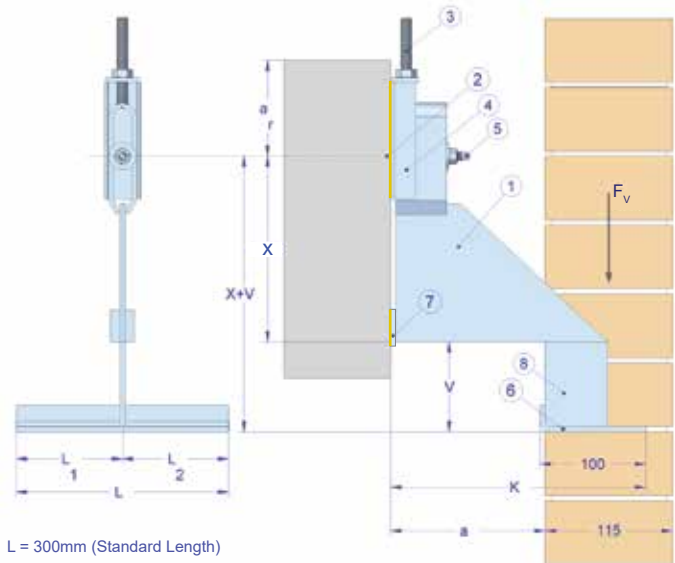

Product Code	Technical Details							
	Projection +/- 15 mm	Load Range	Cavity +/- 15 mm	x size	Bolt Size ¹⁾	Cast-in Channel T Head Bolt ¹⁾	Welded Extension	Welded Support
	K (mm)	F _v (kN)	C (mm)	x (mm)	E.b. (mm)	Cl (mm)	V (mm)	L1/L2 (mm)
FIX-PV-3,5/150	150	3,5	60	150	M12x145	38/17 - M12x80	Determined according to application detail	Determined according to application detail
FIX-PV-3,5/170	170		80	150				
FIX-PV-3,5/190	190		100	150				
FIX-PV-3,5/210	210		120	150				
FIX-PV-3,5/230	230		140	175				
FIX-PV-3,5/250	250		160	175				
FIX-PV-3,5/270	270		180	200				
FIX-PV-3,5/290	290		200	200				
FIX-PV-3,5/310	310		220	220				
FIX-PV-3,5/330	330		240	240				
FIX-PV-3,5/350	350		260	260				
FIX-PV-7,0/150	150		7,0	60				
FIX-PV-7,0/170	170	80		200				
FIX-PV-7,0/190	190	100		200				
FIX-PV-7,0/210	210	120		200				
FIX-PV-7,0/230	230	140		230				
FIX-PV-7,0/250	250	160		250				
FIX-PV-7,0/270	270	180		270				
FIX-PV-7,0/290	290	200		290				
FIX-PV-7,0/310	310	220		310				
FIX-PV-7,0/330	330	240		330				
FIX-PV-7,0/350	350	260		350				
FIX-PV-10,5/150	150	10,5		60	250	M16x185	54/33 - M16x100	Determined according to application detail
FIX-PV-10,5/170	170		80	250				
FIX-PV-10,5/190	190		100	250				
FIX-PV-10,5/210	210		120	250				
FIX-PV-10,5/230	230		140	300				
FIX-PV-10,5/250	250		160	300				
FIX-PV-10,5/270	270		180	320				
FIX-PV-10,5/290	290		200	340				
FIX-PV-10,5/310	310		220	360				
FIX-PV-10,5/330	330		240	380				
FIX-PV-10,5/350	350		260	400				

• Material : Stainless Steel 1.4301 (AISI 304-A2) & 1.4401 (AISI 316-A4) • Load capacities refer to fixings in concrete ≥ C20/25 • Loads stated are allowable loads • Other sizes are available for production upon request • Bolts and channels are provided separately • Structural calculation reports are available upon order • The fastenings has to be calculated for each individual case

FIX-PV Support Bracket

This brickwork support bracket has the same features as the FIX-P bracket, however it has an extension down wards for brick installation above window and door openings. The welded extension plate can be produced in desired lengths.

Product Code Description

FIX-PV - 3,5 / 150 - L / V

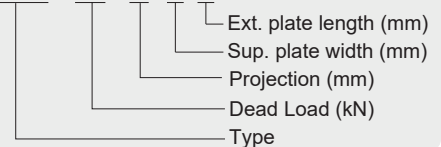

FIX-S Support Bracket - Product Details



- 1 - Bracket body
- 2 - Thermal break
- 3 - Threaded rod
- 4 - Adjustable profile
- 5 - Anchor bolt
- 6 - Support plate
- 7 - Welded pressure plate
- 8 - U insert (to be ordered separately, see page 39)

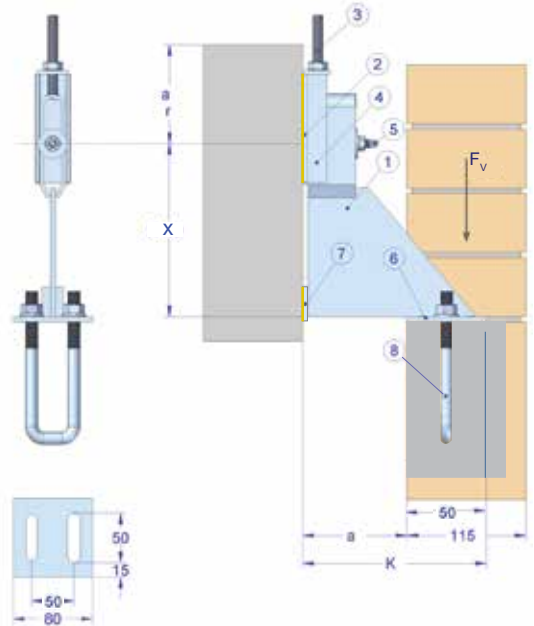

Product Code	Technical Details					
	Projection +/- 15 mm	Load Range	Cavity +/- 15 mm	x size	Bolt Size ¹⁾	Cast-in Channel T Head Bolt ¹⁾
	K (mm)	F _v (kN)	C (mm)	x (mm)	E.b. (mm)	CI (mm)
FIX-S-3,5/150	150	3,5	60	150	M12x145	38/17 - M12x80
FIX-S-3,5/170	170		80	150		
FIX-S-3,5/190	190		100	150		
FIX-S-3,5/210	210		120	150		
FIX-S-3,5/230	230		140	175		
FIX-S-3,5/250	250		160	175		
FIX-S-3,5/270	270		180	200		
FIX-S-3,5/290	290		200	200		
FIX-S-3,5/310	310		220	220		
FIX-S-3,5/330	330		240	240		
FIX-S-3,5/350	350	260	260			
FIX-S-7,0/150	150	7,0	60	200	M12x145	49/30 - M16x100
FIX-S-7,0/170	170		80	200		
FIX-S-7,0/190	190		100	200		
FIX-S-7,0/210	210		120	200		
FIX-S-7,0/230	230		140	230		
FIX-S-7,0/250	250		160	250		
FIX-S-7,0/270	270		180	270		
FIX-S-7,0/290	290		200	290		
FIX-S-7,0/310	310		220	310		
FIX-S-7,0/330	330		240	330		
FIX-S-7,0/350	350	260	350			
FIX-S-10,5/150	150	10,5	60	250	M16x145	54/33 - M16x100
FIX-S-10,5/170	170		80	250		
FIX-S-10,5/190	190		100	250		
FIX-S-10,5/210	210		120	250		
FIX-S-10,5/230	230		140	300		
FIX-S-10,5/250	250		160	300		
FIX-S-10,5/270	270		180	320		
FIX-S-10,5/290	290		200	340		
FIX-S-10,5/310	310		220	360		
FIX-S-10,5/330	330		240	380		
FIX-S-10,5/350	350	260	400			

• Material : Stainless Steel 1.4301 (AISI 304-A2) & 1.4401 (AISI 316-A4) • Load capacities refer to fixings in concrete ≥ C20/25 • Loads stated are allowable loads
 • Other sizes are available for production upon request • Bolts and channels are provided separately • Structural calculation reports are available upon order
 • The fastenings has to be calculated for each individual case

FIX-S Support Bracket

This brickwork support bracket is used for fixing of prefabricated components. A U shaped bar is precasted in to the components which is then fixed on to the support plate which have slotted holes, using nuts and washers. An anchor channel can also be used for casting into prefabricated components.

Product Code Description

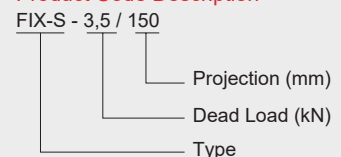

FIX-SV Support Bracket - Product Details



- 1 - Bracket body
- 2 - Thermal break
- 3 - Threaded rod
- 4 - Adjustable profile
- 5 - Anchor bolt
- 6 - Support plate
- 7 - Welded pressure plate
- 8 - U insert (to be ordered separately, see page 39)
- 9 - Extension plate

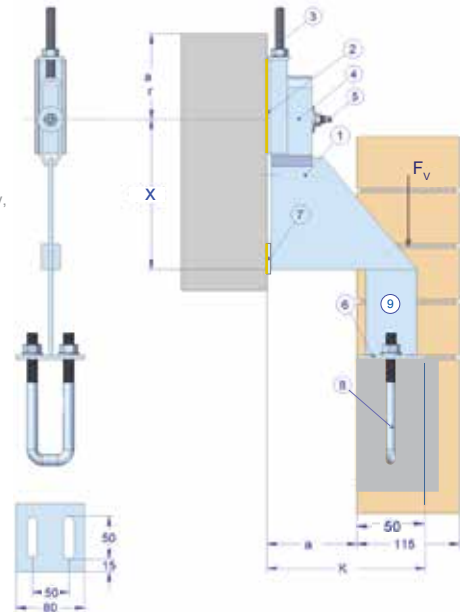

Product Code	Technical Details						
	Projection +/- 15 mm	Load Range	Cavity +/- 15 mm	x size	Bolt Size ¹⁾	Cast-in Channel T Head Bolt ¹⁾	Welded Extension Plate
	K (mm)	F _v (kN)	C (mm)	x (mm)	E.b. (mm)	Cl (mm)	V (mm)
FIX-SV-3,5/150	150	3,5	60	150	M12x145	38/17 - M12x80	Determined according to application detail
FIX-SV-3,5/170	170		80	150			
FIX-SV-3,5/190	190		100	150			
FIX-SV-3,5/210	210		120	150			
FIX-SV-3,5/230	230		140	175			
FIX-SV-3,5/250	250		160	175			
FIX-SV-3,5/270	270		180	200			
FIX-SV-3,5/290	290		200	200			
FIX-SV-3,5/310	310		220	220			
FIX-SV-3,5/330	330		240	240			
FIX-SV-3,5/350	350	260	260				
FIX-SV-7,0/150	150	7,0	60	200	M12x145	49/30 - M16x100	Determined according to application detail
FIX-SV-7,0/170	170		80	200			
FIX-SV-7,0/190	190		100	200			
FIX-SV-7,0/210	210		120	200			
FIX-SV-7,0/230	230		140	230			
FIX-SV-7,0/250	250		160	250			
FIX-SV-7,0/270	270		180	270			
FIX-SV-7,0/290	290		200	290			
FIX-SV-7,0/310	310		220	310			
FIX-SV-7,0/330	330		240	330			
FIX-SV-7,0/350	350	260	350				
FIX-SV-10,5/150	150	10,5	60	250	M16x185	54/33 - M16x100	Determined according to application detail
FIX-SV-10,5/170	170		80	250			
FIX-SV-10,5/190	190		100	250			
FIX-SV-10,5/210	210		120	250			
FIX-SV-10,5/230	230		140	300			
FIX-SV-10,5/250	250		160	300			
FIX-SV-10,5/270	270		180	320			
FIX-SV-10,5/290	290		200	340			
FIX-SV-10,5/310	310		220	360			
FIX-SV-10,5/330	330		240	380			
FIX-SV-10,5/350	350	260	400				

• Material : Stainless Steel 1.4301 (AISI 304-A2) & 1.4401 (AISI 316-A4) • Load capacities refer to fixings in concrete ≥ C20/25 • Loads stated are allowable loads
 • Other sizes are available for production upon request • Bolts and channels are provided separately • Structural calculation reports are available upon order
 • The fastenings has to be calculated for each individual case

FIX-SV Support Bracket

This brickwork support bracket is the same as FIX-S type brickwork support bracket which is used for fixing prefabricated components. There is an extension plate welded for positioning the bracket well above window and door openings.

Product Code Description

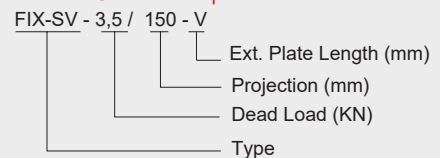

FIX-F Support Bracket - Product Details

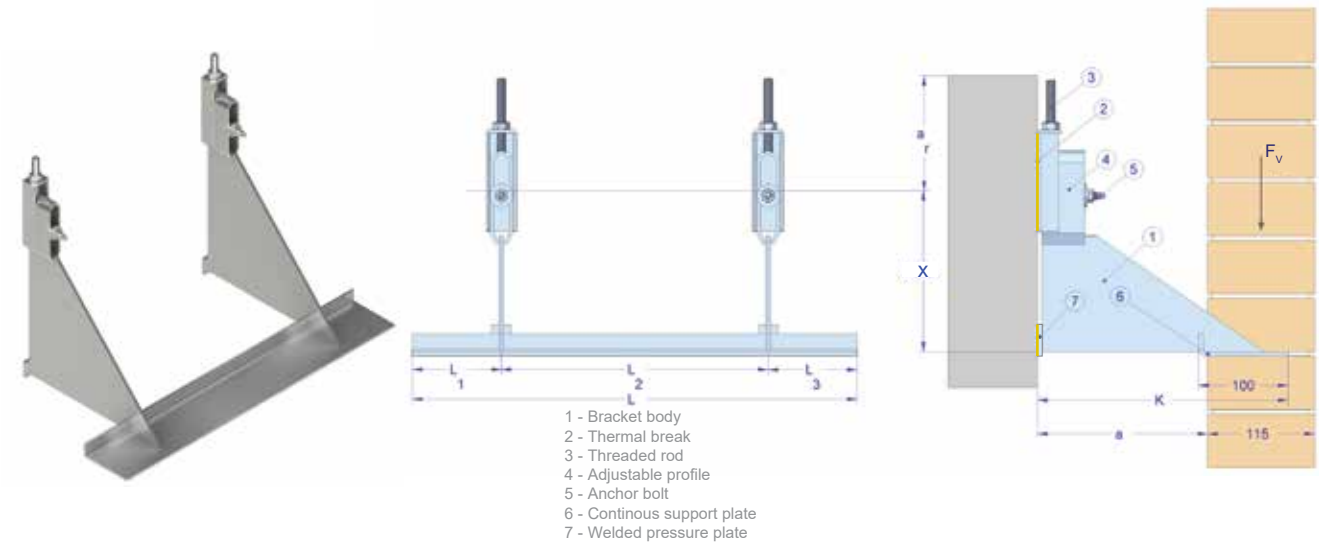

- 1 - Bracket body
- 2 - Thermal break
- 3 - Threaded rod
- 4 - Adjustable profile
- 5 - Anchor bolt
- 6 - Continuous support plate
- 7 - Welded pressure plate

Product Code	Technical Details						
	Projection +/- 15 mm	Load Range	Cavity +/- 15 mm	x size	Bolt Size ¹⁾	Cast-in Channel T Head Bolt ¹⁾	Welded Support Plate
	K (mm)	F _v (kN)	C (mm)	x (mm)	E.b. (mm)	CI (mm)	L (mm)
FIX-F-3,5/150	150	3,5	60	150	M12x145	38/17 - M12x80	Determined according to application detail
FIX-F-3,5/170	170		80	150			
FIX-F-3,5/190	190		100	150			
FIX-F-3,5/210	210		120	150			
FIX-F-3,5/230	230		140	175			
FIX-F-3,5/250	250		160	175			
FIX-F-3,5/270	270		180	180			
FIX-F-3,5/290	290		200	200			
FIX-F-3,5/310	310		220	220			
FIX-F-3,5/330	330		240	240			
FIX-F-3,5/350	350	260	260				
FIX-F-7,0/150/7	150	7,0	60	200	M12x145	49/30 - M16x100	Determined according to application detail
FIX-F-7,0/170/7	170		80	200			
FIX-F-7,0/190/7	190		100	200			
FIX-F-7,0/210/7	210		120	200			
FIX-F-7,0/230/7	230		140	250			
FIX-F-7,0/250/7	250		160	250			
FIX-F-7,0/270/7	270		180	270			
FIX-F-7,0/290/7	290		200	290			
FIX-F-7,0/310/7	310		220	310			
FIX-F-7,0/330/7	330		240	330			
FIX-F-7,0/350/7	350	260	350				
FIX-F-10,5/150	150	10,5	60	250	M16x185	54/33 - M16x100	Determined according to application detail
FIX-F-10,5/170	170		80	250			
FIX-F-10,5/190	190		100	250			
FIX-F-10,5/210	210		120	250			
FIX-F-10,5/230	230		140	300			
FIX-F-10,5/250	250		160	300			
FIX-F-10,5/270	270		180	320			
FIX-F-10,5/290	290		200	350			
FIX-F-10,5/310	310		220	360			
FIX-F-10,5/330	330		240	380			
FIX-F-10,5/350	350	260	400				

- Material : Stainless Steel 1.4301 (AISI 304-A2) & 1.4401 (AISI 316-A4) • Load capacities refer to fixings in concrete ≥ C20/25 • Loads stated are allowable loads
- Other sizes are available for production upon request • Bolts and channels are provided separately • Structural calculation reports are available upon order
- The fastenings has to be calculated for each individual case

FIX-F Support Bracket

This type of brickwork support anchors have a continues welded support. With this, brick cladding can be made along the length of the continues welded L shaped plate. The length of the L plate can be designed according to the application details.

Product Code Description

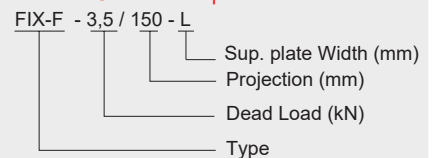

FIX-FV Support Bracket - Product Details

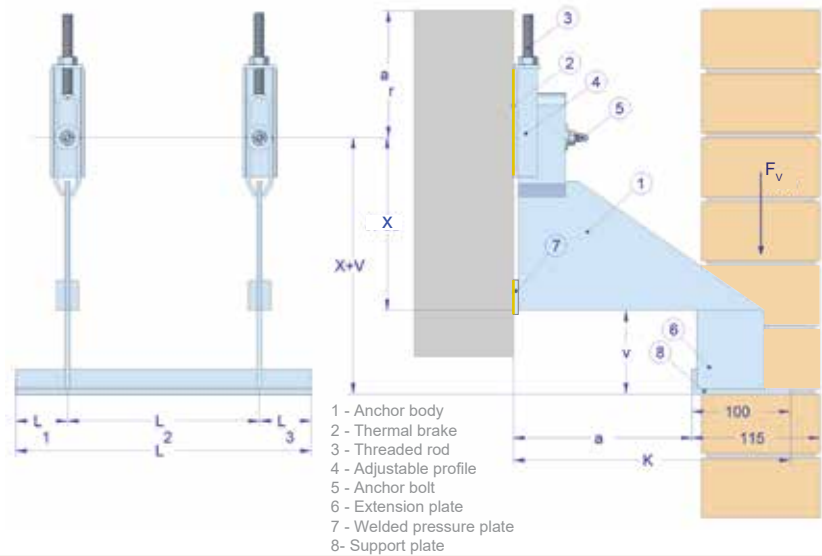

Product Code	Technical Details							
	Projection +/- 15 mm	Load Range	Cavity +/- 15 mm	x size	Bolt Size ¹⁾	Cast-in Channel T Head Bolt ¹⁾	Welded Extension	Welded Support
	K (mm)	F _v (kN)	C (mm)	x (mm)	E.b. (mm)	Cl (mm)	V (mm)	L (mm)
FIX-FV-3,5/150	150	3,5	60	150	M12x135	38/17 - M12x70	Determined according to application detail	Determined according to application detail
FIX-FV-3,5/170	170							
FIX-FV-3,5/190	190							
FIX-FV-3,5/210	210							
FIX-FV-3,5/230	230							
FIX-FV-3,5/250	250							
FIX-FV-3,5/270	270							
FIX-FV-3,5/290	290							
FIX-FV-3,5/310	310							
FIX-FV-3,5/330	330							
FIX-FV-3,5/350	350							
FIX-FV-7,0/150	150	7,0	60	200	M12x135	49/30 - M16x80	Determined according to application detail	Determined according to application detail
FIX-FV-7,0/170	170							
FIX-FV-7,0/190	190							
FIX-FV-7,0/210	210							
FIX-FV-7,0/230	230							
FIX-FV-7,0/250	250							
FIX-FV-7,0/270	270							
FIX-FV-7,0/290	290							
FIX-FV-7,0/310	310							
FIX-FV-7,0/330	330							
FIX-FV-7,0/350	350							
FIX-FV-10,5/150	150	10,5	60	250	M16x145	54/33 - M16x80	Determined according to application detail	Determined according to application detail
FIX-FV-10,5/170	170							
FIX-FV-10,5/190	190							
FIX-FV-10,5/210	210							
FIX-FV-10,5/230	230							
FIX-FV-10,5/250	250							
FIX-FV-10,5/270	270							
FIX-FV-10,5/290	290							
FIX-FV-10,5/310	310							
FIX-FV-10,5/330	330							
FIX-FV-10,5/350	350							

• Material : Stainless Steel 1.4301 (AISI 304-A2) & 1.4401 (AISI 316-A4) • Load capacities refer to fixings in concrete ≥ C20/25 • Loads stated are allowable loads
 • Other sizes are available for production upon request • Bolts and channels are provided separately • Structural calculation reports are available upon order
 • The fastenings has to be calculated for each individual case

FIX-FV Support Bracket

This type of brickwork support bracket has the same properties as the FIX-F type support bracket. The difference is that it has a downward extension plate for brick cladding above window and door openings.

Product Code Description

FIX-FV - 3,5 / 150 - L / V

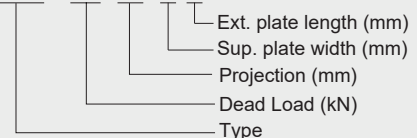

FIX-FSC Support Bracket - Product Details

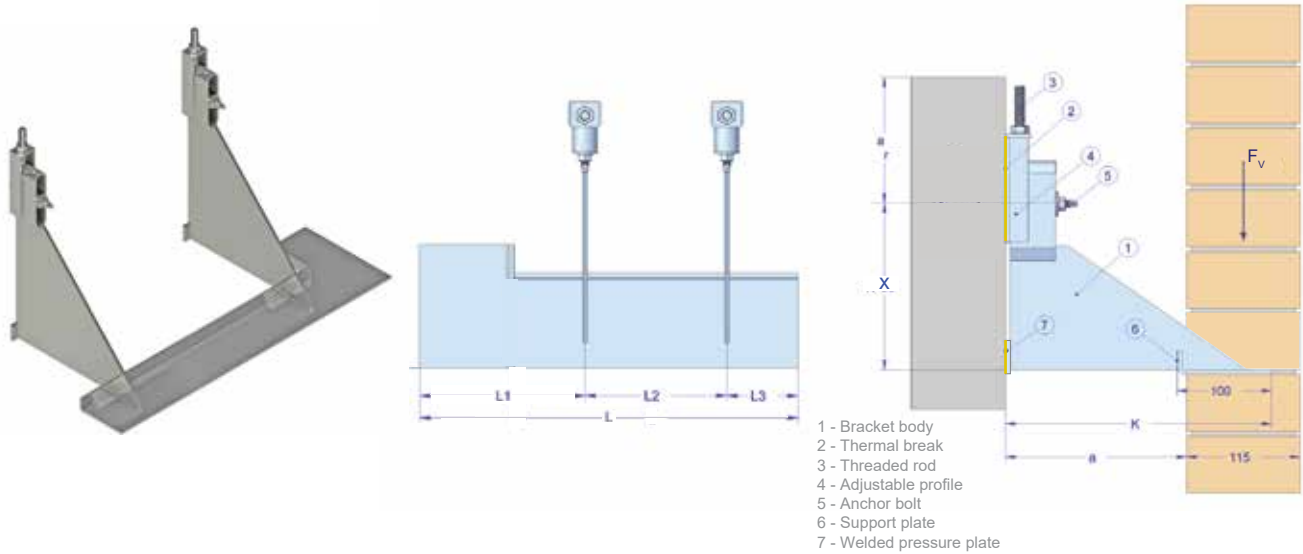

- 1 - Bracket body
- 2 - Thermal break
- 3 - Threaded rod
- 4 - Adjustable profile
- 5 - Anchor bolt
- 6 - Support plate
- 7 - Welded pressure plate

Product Code	Technical Details						
	Projection +/- 15 mm	Load Range	Cavity +/- 15 mm	x size	Bolt Size ¹⁾	Cast-in Channel T Head Bolt ¹⁾	Welded Support Plate
	K (mm)	F _v (kN)	C (mm)	x (mm)	E.b. (mm)	CI (mm)	L (mm)
FIX-FSC-3,5/150	150	3,5	60	150	M12x145	38/17 - M12x80	Determined according to application detail
FIX-FSC-3,5/170	170		80	150			
FIX-FSC-3,5/190	190		100	150			
FIX-FSC-3,5/210	210		120	150			
FIX-FSC-3,5/230	230		140	175			
FIX-FSC-3,5/250	250		160	175			
FIX-FSC-3,5/270	270		180	180			
FIX-FSC-3,5/290	290		200	200			
FIX-FSC-3,5/310	310		220	220			
FIX-FSC-3,5/330	330		240	240			
FIX-FSC-3,5/350	350		260	260			
FIX-FSC-7,0/150	150	7,0	60	200	M12x145	49/30 - M16x100	Determined according to application detail
FIX-FSC-7,0/170	170		80	200			
FIX-FSC-7,0/190	190		100	200			
FIX-FSC-7,0/210	210		120	200			
FIX-FSC-7,0/230	230		140	250			
FIX-FSC-7,0/250	250		160	250			
FIX-FSC-7,0/270	270		180	270			
FIX-FSC-7,0/290	290		200	290			
FIX-FSC-7,0/310	310		220	310			
FIX-FSC-7,0/330	330		240	330			
FIX-FSC-7,0/350	350		260	350			
FIX-FSC-10,5/150	150	10,5	60	250	M16x185	54/33 - M16x100	Determined according to application detail
FIX-FSC-10,5/170	170		80	250			
FIX-FSC-10,5/190	190		100	250			
FIX-FSC-10,5/210	210		120	250			
FIX-FSC-10,5/230	230		140	300			
FIX-FSC-10,5/250	250		160	300			
FIX-FSC-10,5/270	270		180	320			
FIX-FSC-10,5/290	290		200	350			
FIX-FSC-10,5/310	310		220	360			
FIX-FSC-10,5/330	330		240	380			
FIX-FSC-10,5/350	350		260	400			

- Material : Stainless Steel 1.4301 (AISI 304-A2) & 1.4401 (AISI 316-A4) • Load capacities refer to fixings in concrete ≥ C20/25 • Loads stated are allowable loads
- Other sizes are available for production upon request • Bolts and channels are provided separately • Structural calculation reports are available upon order
- The fastenings has to be calculated for each individual case

FIX-FSC Support Bracket

This type of brickwork support bracket has a welded corner support which are used for brick support at wall corners. The length of the welded supports are determined according to the application detail.

Product Code Description

FIX-FSC - 3,5 / 150 - L

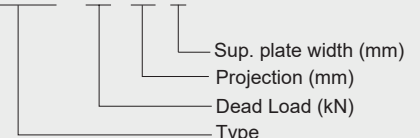

FIX-FDC Support Bracket - Product Details

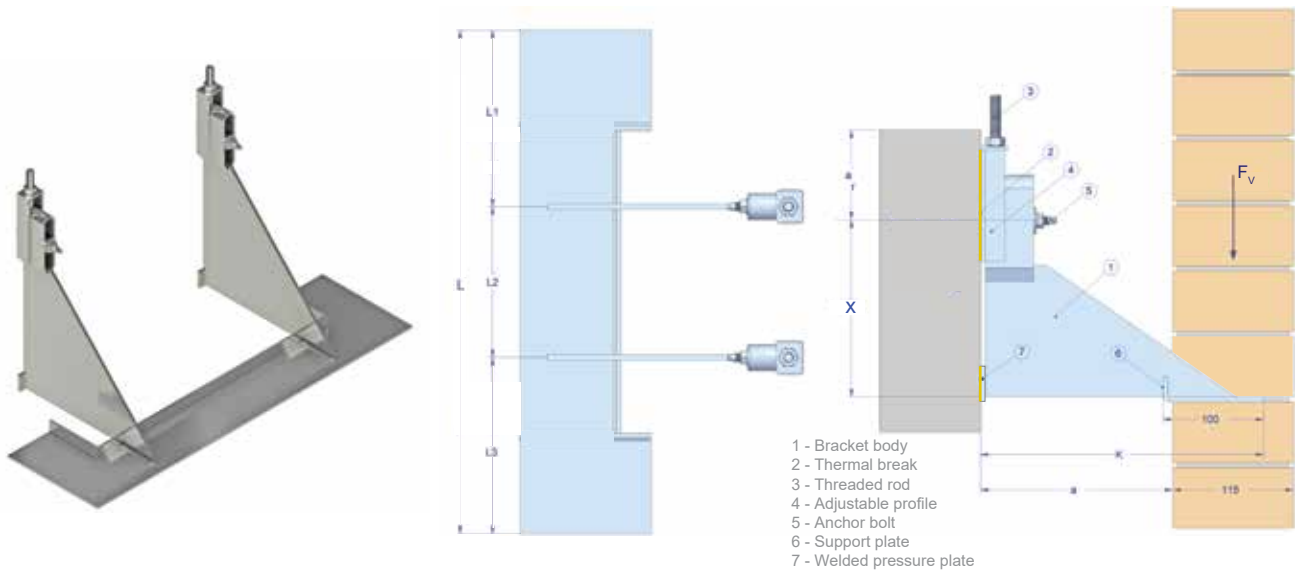

Product Code	Technical Details						
	Projection +/- 15 mm	Load Range	Cavity +/- 15 mm	x size	Bolt Size ¹⁾	Cast-in Channel T Head Bolt ¹⁾	Welded Support Plate
	K (mm)	F _v (kN)	C (mm)	x (mm)	E.b. (mm)	Cl (mm)	L (mm)
FIX-FDC-3,5/150	150	3,5	60	150	M12x145	38/17 - M12x80	Determined according to application detail
FIX-FDC-3,5/170	170		80	150			
FIX-FDC-3,5/190	190		100	150			
FIX-FDC-3,5/210	210		120	150			
FIX-FDC-3,5/230	230		140	175			
FIX-FDC-3,5/250	250		160	175			
FIX-FDC-3,5/270	270		180	180			
FIX-FDC-3,5/290	290		200	200			
FIX-FDC-3,5/310	310		220	220			
FIX-FDC-3,5/330	330		240	240			
FIX-FDC-3,5/350	350	260	260				
FIX-FDC-7,0/150	150	7,0	60	200	M12x145	49/30 - M16x100	Determined according to application detail
FIX-FDC-7,0/170	170		80	200			
FIX-FDC-7,0/190	190		100	200			
FIX-FDC-7,0/210	210		120	200			
FIX-FDC-7,0/230	230		140	250			
FIX-FDC-7,0/250	250		160	250			
FIX-FDC-7,0/270	270		180	270			
FIX-FDC-7,0/290	290		200	290			
FIX-FDC-7,0/310	310		220	310			
FIX-FDC-7,0/330	330		240	330			
FIX-FDC-7,0/350	350	260	350				
FIX-FDC-10,5/150	150	10,5	60	250	M16x185	54/33 - M16x100	Determined according to application detail
FIX-FDC-10,5/170	170		80	250			
FIX-FDC-10,5/190	190		100	250			
FIX-FDC-10,5/210	210		120	250			
FIX-FDC-10,5/230	230		140	300			
FIX-FDC-10,5/250	250		160	300			
FIX-FDC-10,5/270	270		180	320			
FIX-FDC-10,5/290	290		200	350			
FIX-FDC-10,5/310	310		220	360			
FIX-FDC-10,5/330	330		240	380			
FIX-FDC-10,5/350	350	260	400				

- Material : Stainless Steel 1.4301 (AISI 304-A2) & 1.4401 (AISI 316-A4) • Load capacities refer to fixings in concrete ≥ C20/25 • Loads stated are allowable loads
- Other sizes are available for production upon request • Bolts and channels are provided separately • Structural calculation reports are available upon order
- The fastenings has to be calculated for each individual case

FIX-FDC Support Bracket

This type of brickwork support is similar to the FIX-C type support bracket, however it has a welded corner support at both sides of the continues support angle. This support bracket is suitable for installing brick works on columns where there are corners at both sides of the columns on short distances.

Product Code Description

FIX-FDC - 3,5 / 150 - L

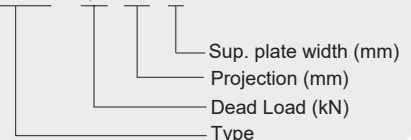

FIX-W Support Bracket - Product Details



- 1 - Bracket body
- 2 - Thermal break
- 3 - Threaded rod
- 4 - Adjustable profile
- 5 - Anchor bolt
- 6 - Support plate
- 7 - Welded pressure plate

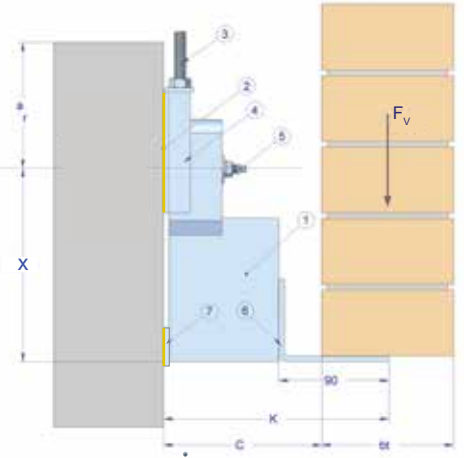
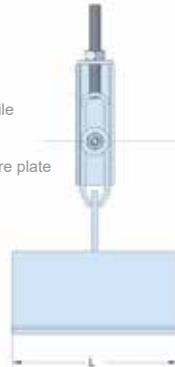

Product Code	Technical Details						
	Projection +/- 15 mm	Load Range	Cavity +/- 15 mm	x size	Bolt Size ¹⁾	Cast-in channel T Head Bolt ¹⁾	Welded Support Plate
	K (mm)	F _v (kN)	C (mm)	x (mm)	E.b. (mm)	CI (mm)	L1/L2 (mm)
FIX-W-3,5/150	150	3,5	60	150	M12x145	38/17 - M12x80	Determined according to application detail
FIX-W-3,5/170	170		80	150			
FIX-W-3,5/190	190		100	150			
FIX-W-3,5/210	210		120	150			
FIX-W-3,5/230	230		140	175			
FIX-W-3,5/250	250		160	175			
FIX-W-3,5/270	270		180	200			
FIX-W-3,5/290	290		200	200			
FIX-W-3,5/310	310		220	220			
FIX-W-3,5/330	330		240	240			
FIX-W-3,5/350	350		260	260			
FIX-W-7,0/150	150	7,0	60	200	M12x145	49/30 - M16x100	Determined according to application detail
FIX-W-7,0/170	170		80	200			
FIX-W-7,0/190	190		100	200			
FIX-W-7,0/210	210		120	200			
FIX-W-7,0/230	230		140	230			
FIX-W-7,0/250	250		160	250			
FIX-W-7,0/270	270		180	270			
FIX-W-7,0/290	290		200	290			
FIX-W-7,0/310	310		220	310			
FIX-W-7,0/330	330		240	330			
FIX-W-7,0/350	350		260	350			

- Material : Stainless Steel 1.4301 (AISI 304-A2) & 1.4401 (AISI 316-A4)
- Load capacities refer to fixings in concrete ≥ C20/25
- Loads stated are allowable loads
- Other sizes are available for production upon request
- Bolts and channels are provided separately
- Structural calculation reports are available upon order
- The fastenings has to be calculated for each individual case

FIX-W Support Bracket

This type of brickwork support bracket has an L plate welded on a single bracket and is used for installing the last brick on a row at the end of a wall. The brackets are primarily used in the edge zones and where there are expansion joints.

Product Code Description

FIX-W - 3,5 / 150 - L

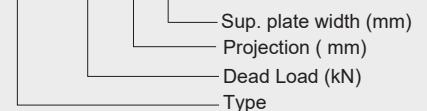

FIX-UT Support Bracket - Product Details



- 1 - Bracket body
- 2 - Thermal break
- 3 - Threaded rod
- 4 - Adjustable profile
- 5 - Anchor bolt
- 6 - Welded pressure plate
- 7 - Support plate

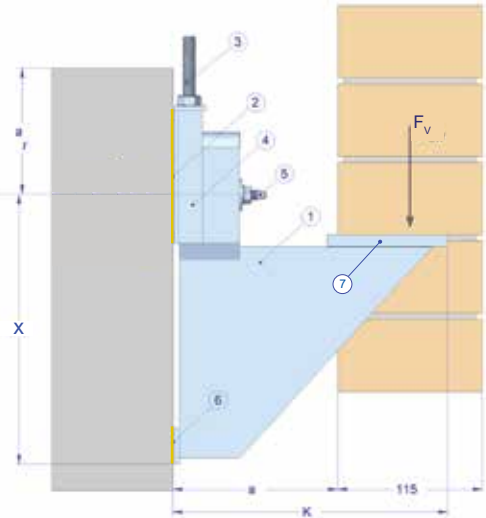

Product Code	Technical Details					
	Projection +/- 15 mm	Load Range	Cavity +/- 15 mm	x size	Bolt Size ¹⁾	Cast-in channel T-Head Bolt ¹⁾
	K (mm)	F _v (kN)	C (mm)	x (mm)	E.b. (mm)	CI (mm)
FIX-UT-3,5/150	150	3,5	60	150	M12x145	38/17 - M12x80
FIX-UT-3,5/170	170		80	150		
FIX-UT-3,5/190	190		100	150		
FIX-UT-3,5/210	210		120	150		
FIX-UT-3,5/230	230		140	175		
FIX-UT-3,5/250	250		160	175		
FIX-UT-3,5/270	270		180	200		
FIX-UT-3,5/290	290		200	200		
FIX-UT-3,5/310	310		220	220		
FIX-UT-3,5/330	330		240	240		
FIX-UT-3,5/350	350		260	260		
FIX-UT-7,0/150	150	7,0	60	200	M12x145	49/30 - M16x100
FIX-UT-7,0/170	170		80	200		
FIX-UT-7,0/190	190		100	200		
FIX-UT-7,0/210	210		120	200		
FIX-UT-7,0/230	230		140	250		
FIX-UT-7,0/250	250		160	250		
FIX-UT-7,0/270	270		180	270		
FIX-UT-7,0/290	290		200	290		
FIX-UT-7,0/310	310		220	310		
FIX-UT-7,0/330	330		240	330		
FIX-UT-7,0/350	350		260	350		
FIX-UT-10,5/150	150	10,5	60	250	M16x185	54/33 - M16x100
FIX-UT-10,5/170	170		80	250		
FIX-UT-10,5/190	190		100	250		
FIX-UT-10,5/210	210		120	250		
FIX-UT-10,5/230	230		140	300		
FIX-UT-10,5/250	250		160	300		
FIX-UT-10,5/270	270		180	350		
FIX-UT-10,5/290	290		200	350		
FIX-UT-10,5/310	310		220	360		
FIX-UT-10,5/330	330		240	380		
FIX-UT-10,5/350	350		260	400		

• Material : Stainless Steel 1.4301 (AISI 304-A2) & 1.4401 (AISI 316-A4) • Load capacities refer to fixings in concrete ≥ C20/25 • Loads stated are allowable loads • Other sizes are available for production upon request • Bolts and channels are provided separately • Structural calculation reports are available upon order
 1) The fastenings has to be calculated for each individual case

FIX-UT Support Bracket

This type of brickwork support bracket is used for brick installation where the support levels are higher than the FIX-UT type support bracket. The support level is in the same level as the fixing point on the wall.

Product Code Description

FIX-UT - 3,5 / 150

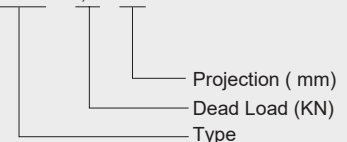

Brickwork Support Brackets - Application Examples

FIX brickwork support brackets can be custom designed to accommodate the special application requirements. Below are some examples of what could be designed and produced to cover the design requirements. Custom design is made in our technical department and project drawings are prepared and submitted for approval.

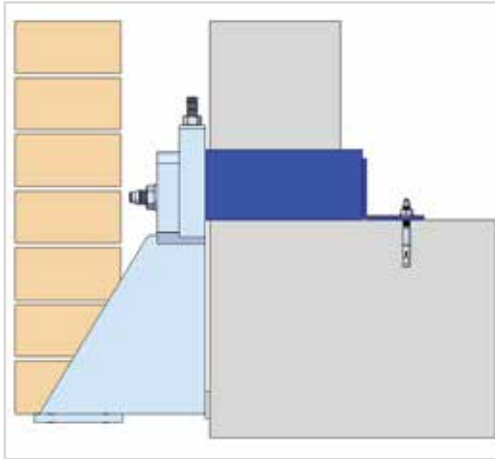

Fixing On Thin Inner Walls

Brackets are bolted on to specially designed elements that allow bolting on to concrete beam upper surface

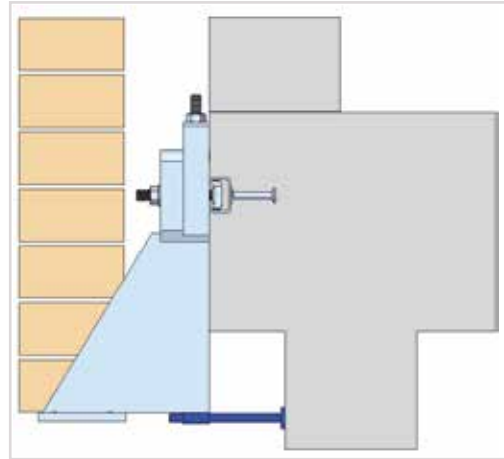

Lateral Adjustability

In circumstances where adjustability of the projection size is required, an adjusting screw is welded on the brackets

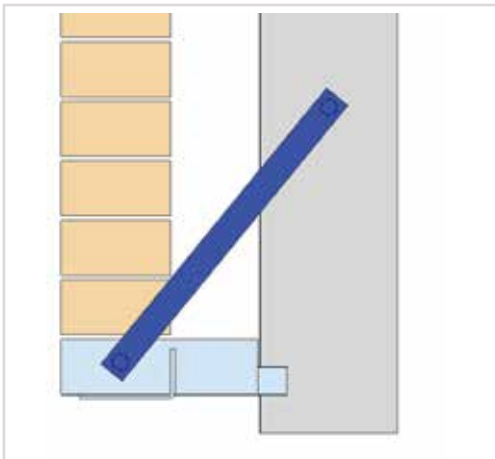

Fixing When Close To Wall Edges

A tie strap can be used for fixing the brackets on the side of the wall

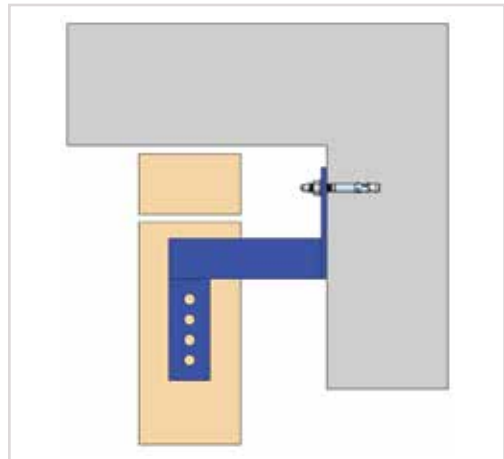

Low Height Brick Work Installation

Special bracket design can be made for installation bricks positioned on edges where there is a low installation height

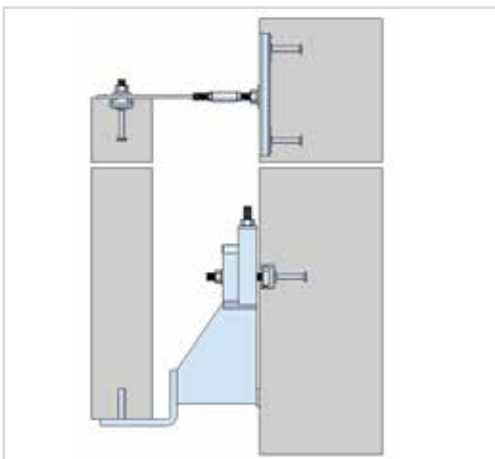

Fixing Of Prefabricated Components

Brackets can be supplied with pins for supporting the prefabricated components. Anchor channels and wall ties can be used for restraining purposes

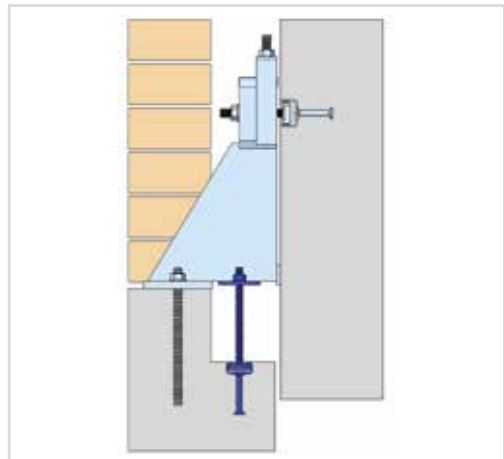

Fixing Of Prefabricated Lintels

Brackets can be supplied with an additional plate where threaded rods can be connected for supporting the load of the prefabricated component

Brickwork Support Systems - Application Examples

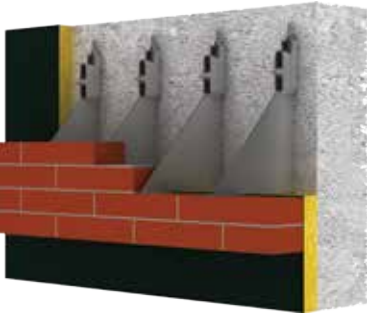

- Brickwork facing wall supporting system with **FIX-U** single brackets. Bracket fixing to wall with through bolt.

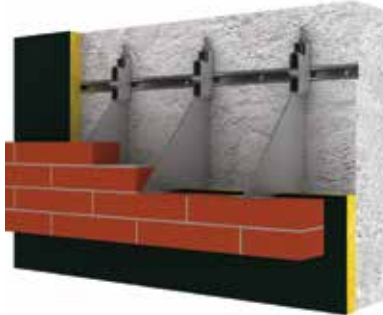

- Brickwork facing wall supporting system with **FIX-U** single brackets. Bracket fixing to wall with cast-in channel.

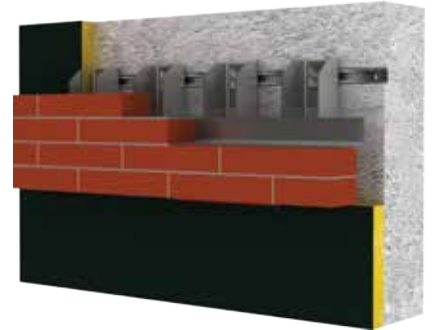

- Brickwork facing wall supporting system with **HMCS** continuous brickwork supports



- Brickwork facing wall supporting with **HMS-AW** brickwork support angle

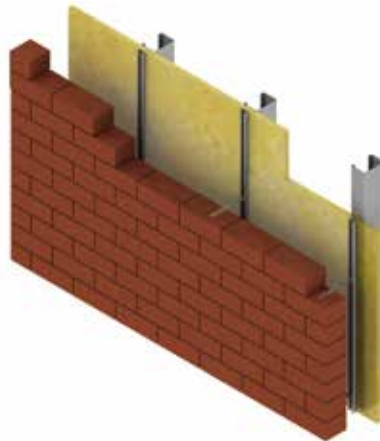

- Brickwork facing walls restraining system with **CMWT** restraint channels & ties



- Brickwork facing walls restraining system with **HMS-AV** restraint channels & ties

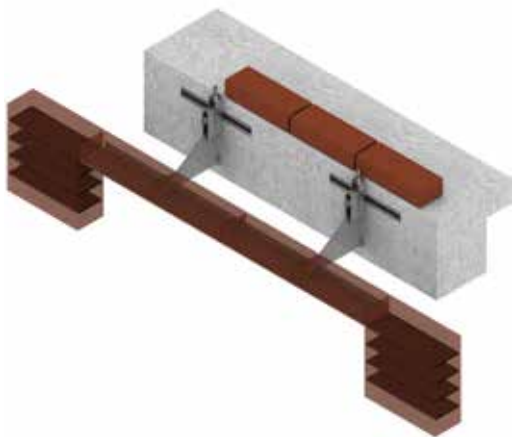

- **FIX-P** brickwork support brackets for supporting bricks above openings

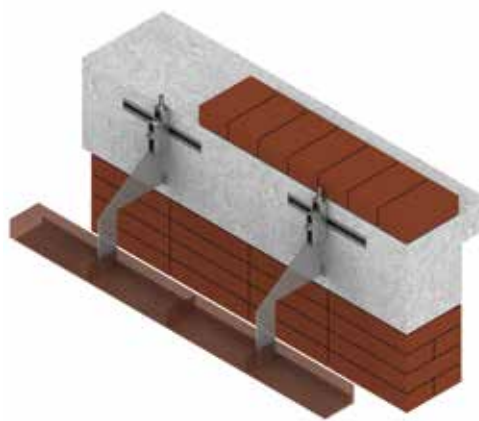

- **FIX-PV** brickwork support brackets for supporting bricks above openings

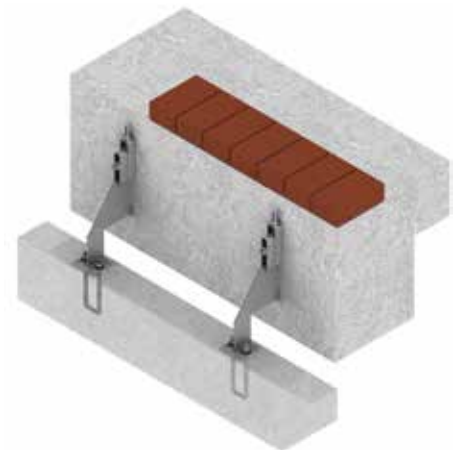

- **FIX-SV** brickwork support brackets for supporting prefabricated components

ISO-FIX Brickwork Support Bracket - Product Details

ISO-FIX Brickwork support brackets is an environmentally friendly product that helps to reduce energy consumptions. With its patented design, it reduces cold bridging significantly. There is a round part that is laser cut on the body which decreases the rate of cold bridge transfer to the wall. Thermal break pads are also used that reduces the cold bridging effect to the walls. The ISO-FIX product features is available for the whole HMS-FIX range.

- Significant reduction in cold bridging with its developed design and use of thermal breaks
- No bending moment on the fixing bolts with the use of FIX adjustable plate
- No point load on the fixing bolts because of the FIX adjustable plate
- Fast installation & adjustability in the vertical axis. One person can easily do the installation

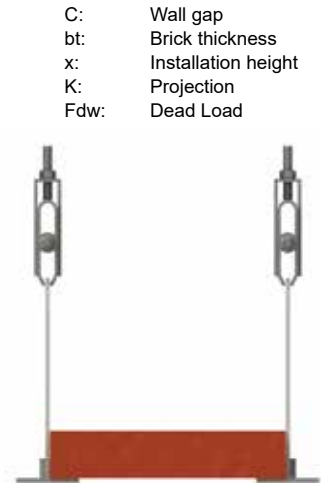
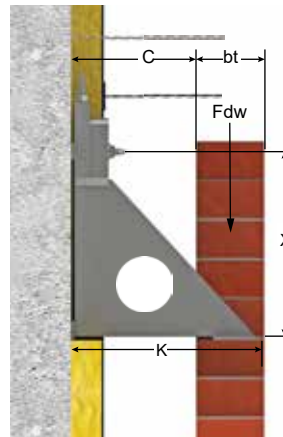

Cavity a (mm)	Load Category 3,5 kN FRd = 4,7 kN		Load Category 7,0 kN FRd = 9,5 kN		Load Category 10,5 kN FRd = 14,2 kN	
	Projection K (mm)	x size (mm)	Projection K (mm)	x size (mm)	Projection K (mm)	x size (mm)
60 ± 15	150	150	150	200	150	250
80 ± 15	170	150	170	200	170	250
100 ± 15	190	150	190	200	190	250
120 ± 15	210	150	210	200	210	250
140 ± 15	230	175	230	250	230	300
160 ± 15	250	175	250	250	250	300
180 ± 15	270	180	270	270	270	320
200 ± 15	290	200	290	290	290	350
220 ± 15	310	220	310	310	310	360
240 ± 15	330	240	330	330	330	380
260 ± 15	350	260	350	350	350	400

Anchor bolt	HB03 M12x145	HB03 M12x145	HB03 M16x185
Anchor channel	HMPR 38/17 with T head bolt M12x80	HMPR 49/30 with T head bolt M16x100	HMPR 54/33 with T head bolt M16x100

ISO-FIX-U Brickwork Support Bracket

This brickwork anchor is designed to reduce cold bridging. There is a laser cut out on the body that reduces the transfer of cold bridging to the substrate. Also thermal break pads are used which are positioned between the bracket and the wall.

Product Code Description

ISO-FIX-U -150 / 3,5

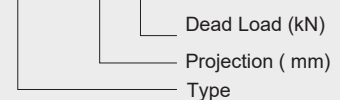

FIX-AP Adjustable Profile - Product Information

The **FIX-AP** adjustable profile is a patented product that is used as a complementary product with the **FIX** brackets.

The adjustable profile enables quick and secure adjustability in the vertical axis. Unlike the traditional set screw, using the adjustable profile offers the installer adjustment the brackets without the need for a second hand assistance.

The primary advantage of the adjustable profile is that it eliminates offset moment loads on the bolts, therefore the requirement for bending moment testing on bolts is not necessary.

FIX-AP Adjustable Profile

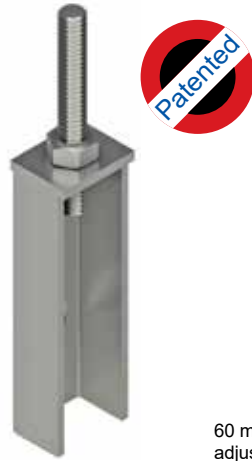

- Adjustability of the bracket is made by the adjustable profile and the threaded bar that is fixed on the profile with a nut. The bar is inserted in the tabbed hole on the upper part of the bracket.

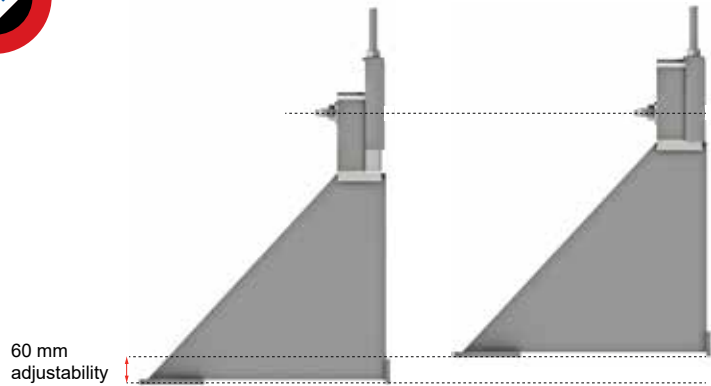

FIX Brickwork Support Bracket - Product Range

The **FIX** brackets are available for the complete range of the **FIX** Brickwork support brackets. The patented special adjustable profile is compatible with all the **FIX** type brackets. The adjustable profile and a threaded rod is used instead of a set screw and nut in order to regulate the vertical adjustment.

FIX-U



FIX-UV



FIX-P



FIX-PV



FIX-S



FIX-SV



FIX-W



FIX-UT



FIX-F



FIX-FV



HMCS Brickwork Continuous Support - Introduction

The **HMCS** brickwork continuous supports consists of a series of U brackets with welded angles. There are welded milled shims on the U brackets that enable secure positioning in the vertical axis, after adjustment.

These brackets can be used in load categories up to 14 kN and can be used for projection sizes from 130 to 230 mm. Vertical adjustability is possible up to 25 mm and adjustability of the projection size is made up to 10 mm provided full height shims are used. The **HMCS** brickwork brackets can be designed and manufactured in a wide range of shapes and dimensions to suit the requirements of the project.

The **HMCS** continues brickwork supports are available in 1,5 metres and can be manufactured with either 3, 4 or 5 U brackets, depending on the load specifications. These products are available in stainless steel 1.4301 (AISI 304) and 1.4401 (AISI 316)



HMCS Brickwork Continuous Support

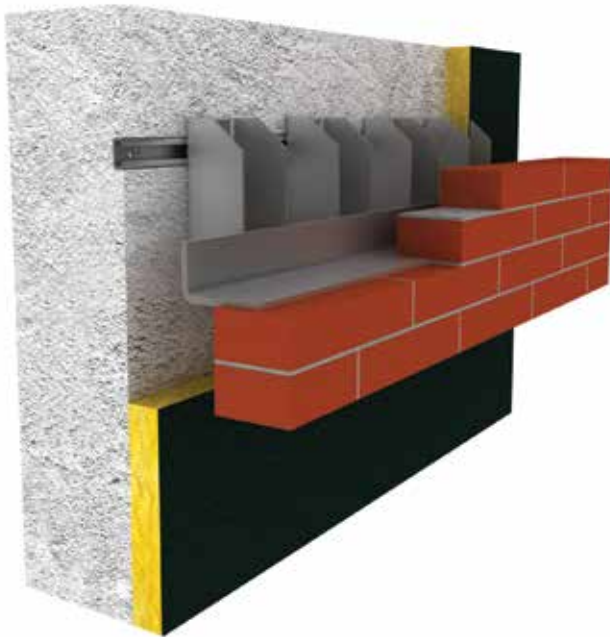

• Perspective picture of brick facing installation with **HMCS** continuous support

Type 1 Continuous support with 5 welded brackets



Type 2 Continuous support with 4 welded brackets

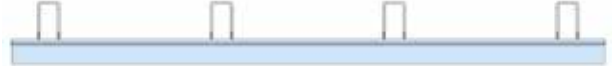

Type 3 Continuous support with 3 welded brackets



• available up to 1,5 metres with 3 different bracket spacings.

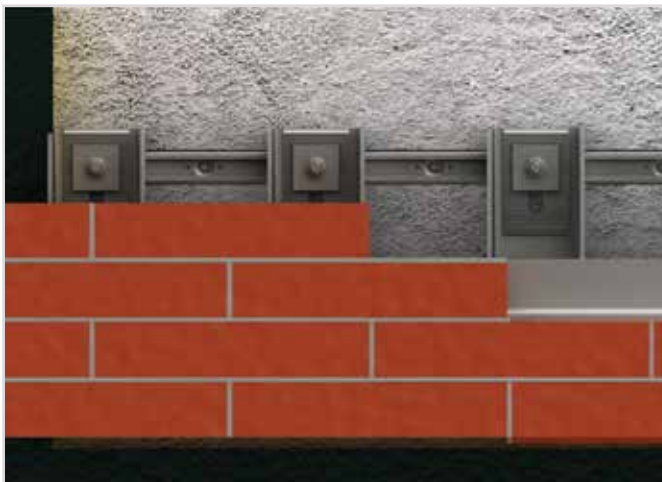

• Elevation picture of brick facing installation with **HMCS** supports

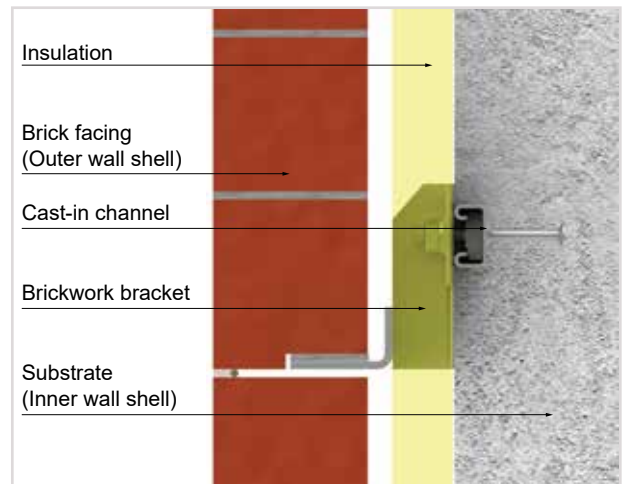

• Section picture of brick facing wall

HMCS Brickwork Continues Support Bracket - Product Details

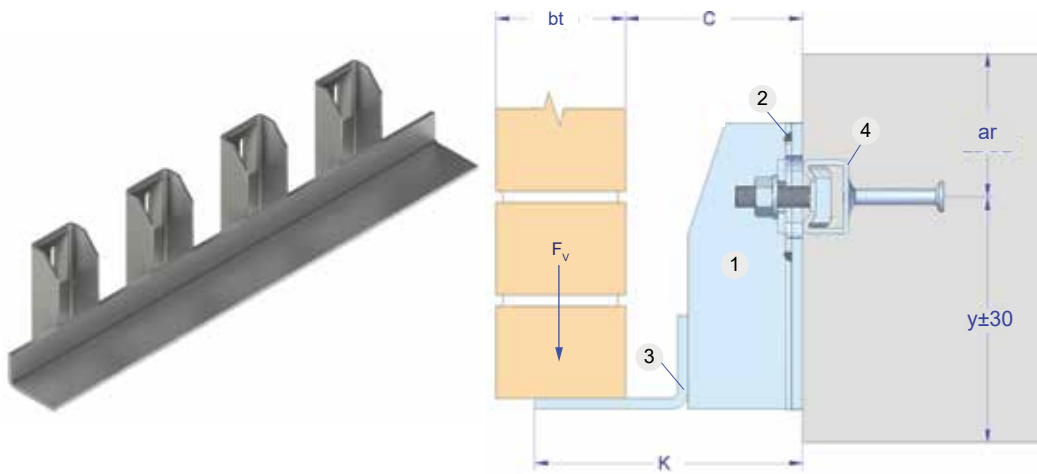

Support set elements:

- 1 - U Shaped bracket with vertical slot hole
- 2 - Welded serrated washer
- 3 - Welded support plate
- 4 - Anchor channel for attachments

Product Code	Technical Details						
	Projection	Dead Load	Cavity	Bolt Height	Bolt Size	Bolt Spacing	Anchor Channel
	K (mm)	F _{dw} (kN)	C (mm)	X (mm)	E.b. (mm)	SC	CI (mm)
HMCS-130/3.5	130	3.50	60	115	M10x90	460	28/15
HMCS-150/3.5	150		80				
HMCS-170/3.5	170		100				
HMCS-190/3.5	190		120				
HMCS-210/3.5	210		140				
HMCS-230/3.5	230	160					
HMCS-130/7	130	7.00	60	115	M12x110	370	38/17
HMCS-150/7	150		80				
HMCS-170/7	170		100				
HMCS-190/7	190		120				
HMCS-210/7	210		140				
HMCS-230/7	230	160					
HMCS-130/10.5	130	10.50	60	135	M12x110	400	40/25
HMCS-150/10.5	150		80				
HMCS-170/10.5	170		100				
HMCS-190/10.5	190		120				
HMCS-210/10.5	210		140				
HMCS-230/10.5	230	160					
HMCS-130/14	130	14.00	60	150	M16x130	350	49/30
HMCS-150/14	150		80				
HMCS-170/14	170		100				
HMCS-190/14	190		120				
HMCS-210/14	210		140				
HMCS-230/14	230	160					
HMCS-130/18	130	18.00	60	150	M16x130	300	49/30
HMCS-150/18	150		80				
HMCS-170/18	170		100				
HMCS-190/18	190		120				
HMCS-210/18	210		140				
HMCS-230/18	230	160					

• Material : Stainless Steel 1.4301 (AISI 304-A2) & 1.4401 (AISI 316-A4) • Load capacities refer to fixings in concrete ≥ C20/25 • Loads stated are allowable loads • Other sizes are available for production upon request • Bolts and channels are provided separately • Structural calculation reports are available upon order

HMCS Brickwork Continuous Support

The continuous brickwork supports are available in 1.5 metres as a standard length and can be specially designed to meet the application requirements. Adjustability in the vertical axis is made with milled serrated washers and a maximum of 10 mm lateral adjustability possible with full height shims

Product Code Description

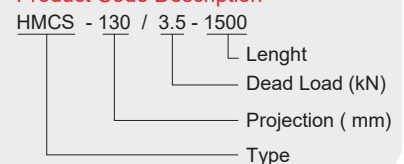

HMCS-UT Brickwork Continues Support Bracket - Product Details

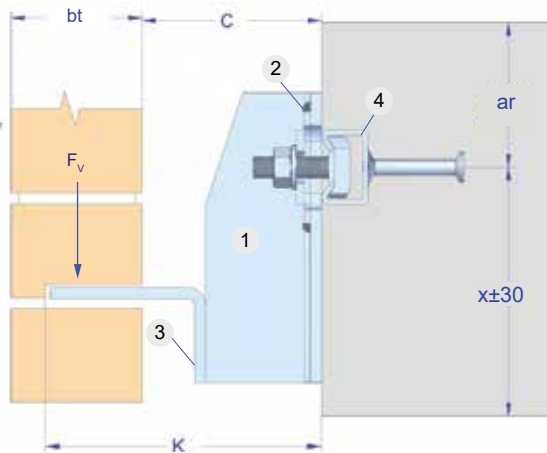

Support set elements:

- 1 - U Shaped bracket with vertical slot hole
- 2 - Welded serrated washer
- 3 - Welded support plate
- 4 - Anchor channel for attachments

Product Code	Technical Details						
	Projection	Dead Load	Cavity	Bolt Height	Bolt Size	Bolt Spacing	Anchor Channel
	K (mm)	F _{dw} (kN)	C (mm)	X (mm)	E.b. (mm)	SC	CI (mm)
HMCS-UT-130/3.5	130	3.50	60	115	M10x90	460	28/15
HMCS-UT-150/3.5	150		80				
HMCS-UT-170/3.5	170		100				
HMCS-UT-190/3.5	190		120				38/17
HMCS-UT-210/3.5	210		140				
HMCS-UT-230/3.5	230		160				
HMCS-UT-130/7	130	7.00	60	115	M12x110	370	38/17
HMCS-UT-150/7	150		80				
HMCS-UT-170/7	170		100				
HMCS-UT-190/7	190		120				40/25
HMCS-UT-210/7	210		140				
HMCS-UT-230/7	230		160				
HMCS-UT-130/10.5	130	10.50	60	135	M12x110	400	40/25
HMCS-UT-150/10.5	150		80				
HMCS-UT-170/10.5	170		100				
HMCS-UT-190/10.5	190		120				49/30
HMCS-UT-210/10.5	210		140				
HMCS-UT-230/10.5	230		160				
HMCS-UT-130/14	130	14.00	60	150	M16x130	350	49/30
HMCS-UT-150/14	150		80				
HMCS-UT-170/14	170		100				
HMCS-UT-190/14	190		120				
HMCS-UT-210/14	210		140				
HMCS-UT-230/14	230		160				
HMCS-UT-130/18	130	18.00	60	150	M16x130	300	49/30
HMCS-UT-150/18	150		80				
HMCS-UT-170/18	170		100				
HMCS-UT-190/18	190		120				
HMCS-UT-210/18	210		140				
HMCS-UT-230/18	230		160				

• Material : Stainless Steel 1.4301 (AISI 304-A2) & 1.4401 (AISI 316-A4) • Load capacities refer to fixings in concrete \geq C20/25 • Loads stated are allowable loads
 • Other sizes are available for production upon request • Bolts and channels are provided separately • Structural calculation reports are available upon order

HMCS-UT Brickwork Continuous Support

The continuous brickwork support is similar to the HMCS-UT brickwork continues support however the welded angle support is positioned upside down. This raises the support level of the brickwork installation. This can be manufactured according to the requirements of the application.

Product Code Description

HMCS-UT - 130 / 3.5 - 1500

- Length
- Dead Load (kN)
- Projection (mm)
- Type

HMS-SB Brickwork Support Bracket - Product Details

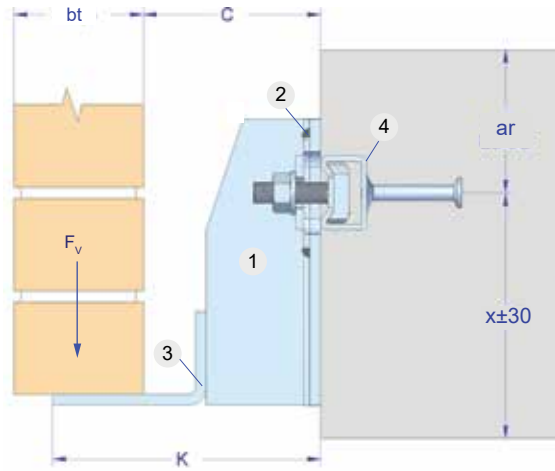

Support set elements:

- 1 - U Shaped bracket with vertical slot hole
- 2 - Welded serrated washer
- 3 - Welded support plate
- 4 - Anchor channel for attachments

Product Code	Technical Details						
	Projection	Dead Load	Cavity	Bolt Height	Bolt Size	Bolt Spacing	Anchor Channel
	K (mm)	F _{dw} (kN)	C (mm)	X (mm)	E.b. (mm)	SC	CI (mm)
HMCS-SB-130/3.5	130	3.50	60	115	M10x90	460	28/15
HMCS-SB-150/3.5	150		80				
HMCS-SB-170/3.5	170		100				
HMCS-SB-190/3.5	190		120				
HMCS-SB-210/3.5	210		140				
HMCS-SB-230/3.5	230	160					
HMCS-SB-130/7	130	7.00	60	115	M12x110	370	38/17
HMCS-SB-150/7	150		80				
HMCS-SB-170/7	170		100				
HMCS-SB-190/7	190		120				
HMCS-SB-210/7	210		140				
HMCS-SB-230/7	230	160					
HMCS-SB-130/10.5	130	10.50	60	135	M12x110	400	40/25
HMCS-SB-150/10.5	150		80				
HMCS-SB-170/10.5	170		100				
HMCS-SB-190/10.5	190		120				
HMCS-SB-210/10.5	210		140				
HMCS-SB-230/10.5	230	160					
HMCS-SB-130/14	130	14.00	60	150	M16x130	350	49/30
HMCS-SB-150/14	150		80				
HMCS-SB-170/14	170		100				
HMCS-SB-190/14	190		120				
HMCS-SB-210/14	210		140				
HMCS-SB-230/14	230	160					
HMCS-SB-130/18	130	18.00	60	150	M16x130	300	49/30
HMCS-SB-150/18	150		80				
HMCS-SB-170/18	170		100				
HMCS-SB-190/18	190		120				
HMCS-SB-210/18	210		140				
HMCS-SB-230/18	230	160					

• Material : Stainless Steel 1.4301 (AISI 304-A2) & 1.4401 (AISI 316-A4) • Load capacities refer to fixings in concrete ≥ C20/25 • Loads stated are allowable loads • Other sizes are available for production upon request • Bolts and channels are provided separately • Structural calculation reports are available upon order

HMCS-SB Brickwork Support Bracket

The brickwork support bracket is an angle with a single bracket that is used for the installation of bricks and stone blocks on tot straight and curves walls. This brick support bracket can be supplied with welded pins and an angle with various degress used for installing stone blocks from the rear surface.

Product Code Description

HMCS-SB - 130 / 3.5

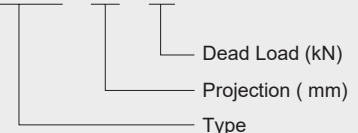

HMS-AW Continuous Angled Supports - Product Details

HMS Angled supports are simple fixing systems used for supporting brickwork walls. These anchors do not have vertical adjustability, and horizontal adjustment can be made through the slotted holes drilled at each 25 cm. The use of these types of systems are preferred if the air layer and insulation need to be fully covered. These anchors can be fixed on concrete walls either with cast in channels, expansion bolts or chemical anchor bolts. Available in stainless steel grade 1.4301 (AISI 304) & 1.4401 (AISI 316), they can be produced in any length up to 3 metres according to the desired application.

HMS-AW Continuous Angled Support

- Used for small cavity space between 20 and 40mm
- Bricks can be positioned in desired position
- Projection sizes of 110 and 130 mm
- Load capacity up to 3.2 kN

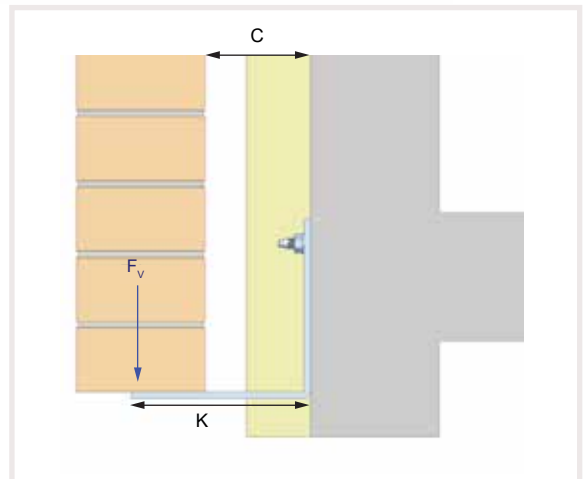
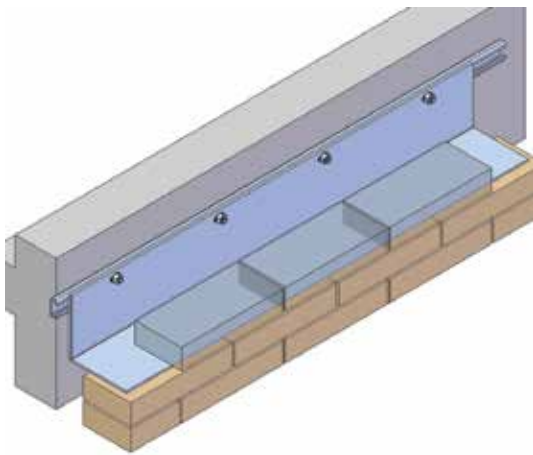
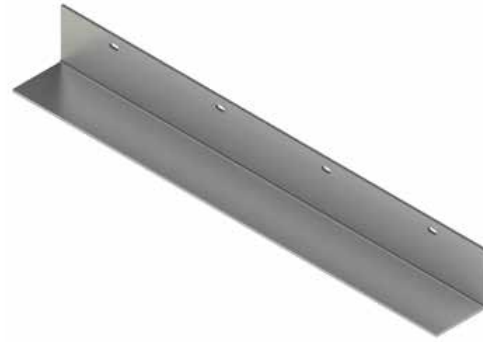

Product Code	Technical Details								
	Projection	Allow.Load Capacity	Cavity	Bolt Height	Angle Size	Expansion Bolt Size	Bolt Spacing	Cast-in Channel	Angle Max Length
	K (mm)	Fdw (kN)	C (mm)	X (mm)	(mm)	E.b. (mm)	SC	CI (mm)	L (mm)
HMS-AW-110/1.2	110	1.20	0-20	84	4x110/110	M10x90	250	38/17	3000
HMS-AW-110/2.1	110	2.10	0-20	83	5x110/110				
HMS-AW-110/3.2	110	3.20	0-20	82	6x110/110				
HMS-AW-130/1.2	130	1.20	20-40	104	4x110/110	M10x90	250	38/17	3000
HMS-AW-130/2.1	130	2.10	20-40	103	5x110/110				
HMS-AW-130/3.2	130	3.20	20-40	102	6x110/110				

- Load capacities refer to fixings in concrete \geq C20/25
- Material : Stainless Steel 1.4301 (A2) & 1.4401 (A4)
- Expansion bolts and cast-in channels are provided separately
- Structural calculation reports are available upon order

HMS-AW Continuous Angle Support

Continuous angle supports are supplied in standard 3 metre lengths. Special lengths can be manufactured according to application details

Product Code Description

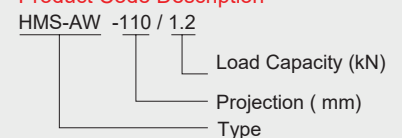

HMS-AWS Continuous Angle Supports - Product Details

HMS-AWS Continuous Angle Support

- Used for cavity spaces between 40 and 240mm
- Welded support plates for loading at high projections
- Projection sizes of 130 to 330 mm
- Load capacity up to 3.2 kN

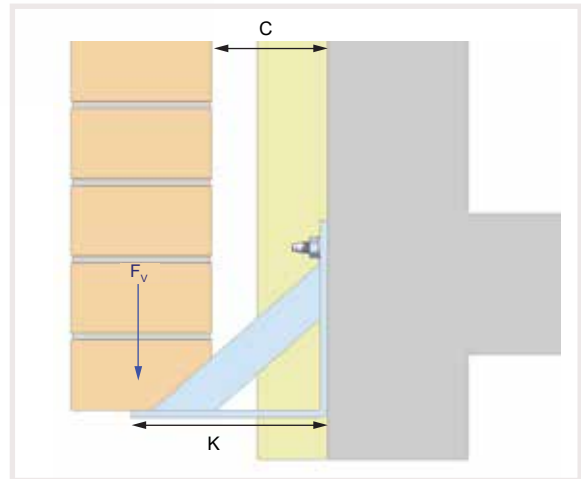
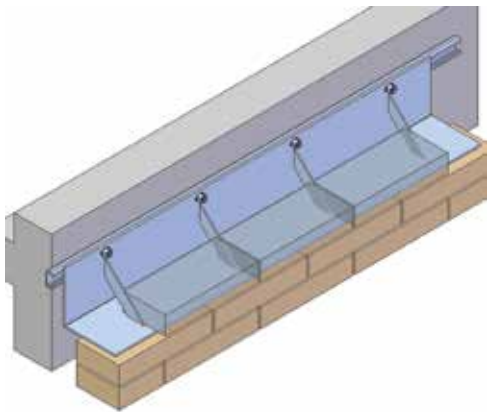
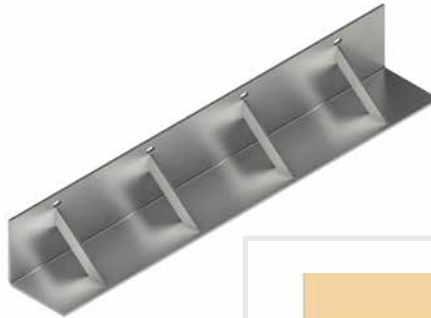

Product Code	Technical Details								
	Projection	Dead Load	Cavity	Bolt Height	Angle Size	Bolt Size	Bolt Spacing	Cast-in Channel	max Length
	K (mm)	F _{dw} (kN)	C (mm)	X (mm)	(mm)	E.b. (mm)	SC	CI (mm)	L (mm)
HMS-AWS-130/1.5 HMS-AWS-130/3.2	130	1.50 3.20	40	105 103	4x110/110 5x110/110	M10x90	250	38/17	3000
HMS-AWS-150/1.5 HMS-AWS-150/3.2	150	1.50 3.20	60	125 123	4x110/110 5x110/110	M10x90	250	38/17	3000
HMS-AWS-170/1.5 HMS-AWS-170/3.2	170	1.50 3.20	80	145 143	4x110/110 5x110/110	M10x90	250	38/17	3000
HMS-AWS-190/1.5 HMS-AWS-190/3.2	190	1.50 3.20	100	165 163	4x110/110 5x110/110	M10x90	250	38/17	3000
HMS-AWS-210/1.5 HMS-AWS-210/3.2	210	1.50 3.20	120	185 183	4x110/110 5x110/110	M10x90	250	38/17	3000
HMS-AWS-230/1.5 HMS-AWS-230/3.2	230	1.50 3.20	140	205 203	4x110/110 5x110/110	M10x90	250	38/17	3000
HMS-AWS-250/1.5 HMS-AWS-250/3.2	250	1.50 3.20	160	84 83	4x110/110 5x110/110	M10x90	250	38/17	3000
HMS-AWS-270/1.5 HMS-AWS-270/3.2	270	1.50 3.20	180	84 83	4x110/110 5x110/110	M10x90	250	38/17	3000
HMS-AWS-290/1.5 HMS-AWS-290/3.2	290	1.50 3.20	200	84 83	4x110/110 5x110/110	M10x90	250	38/17	3000
HMS-AWS-310/1.5 HMS-AWS-310/3.2	310	1.50 3.20	220	84 83	4x110/110 5x110/110	M10x90	250	38/17	3000
HMS-AWS-330/1.5 HMS-AWS-330/3.2	330	1.50 3.20	240	84 83	4x110/110 5x110/110	M10x90	250	38/17	3000

- Load capacities refer to fixings in concrete \geq C20/25
- Material : Stainless Steel 1.4301 (A2) & 1.4401 (A4)
- Expansion bolts and cast-in channels are provided separately
- Structural calculation reports are available upon order

HMS-AWS Continuous Angle Support

Continuous angle supports with welded belts are supplied in standard 3 metre lengths. Special lengths can be manufactured according to application details

Product Code Description

HMS-AWS -150 / 1.5

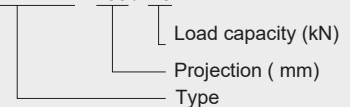

HMS-ES & GS Prefabricated Component Inserts - Product Details

The **HMS-ES** and **HMS-GS** inserts are used for the suspension of prefabricated components. The prefabricated components are fitted with these inserts and are then fixed on to the brickwork support anchor type **HMS-S**.

The inserts are supplied with accessories such as T bolts and / or nuts and washers for fastening on to brickwork support anchors. available in stainless steel grade 1.4301 & 1.4401.

The inserts are designed to carry the loads that are carried by the standard HMS brickwork support anchors. The available load categories are 3.5 kN, 7.0 kN and 10.5 kN.

The structural analysis of the prefabricated component must be made by the prefabrication manufacturer or the structural engineer at the job site, in order to meet the required load performance.

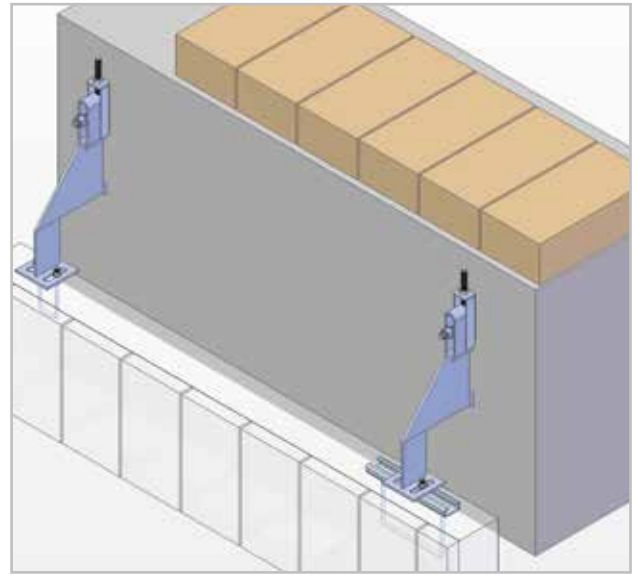

HMS-ES Channel Insert

Product Code	Technical Details	
	Dead Load	Accessories
	Fdw (kN)	
HMS-ES-3.5	3.5	2x T bolt M10x40 2x DIN 9021 washer M10
HMS-ES-7.0	7.0	2x DIN 934 nut M10
HMS-ES-10.5	10.5	2x T bolt M12x50 2x DIN 9021 washer M12 2x DIN 934 nut M12

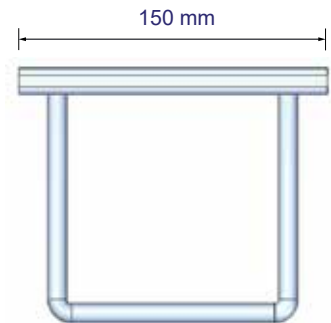

HMS-GS Loop Insert

Product Code	Technical Details	
	Dead Load	Accessories
	Fdw (kN)	
HMS-GS-3.5	3.5	2x DIN 9021 washer M8 2x DIN 934 nut M8
HMS-GS-7.0	7.0	
HMS-GS-10.5	10.5	2x DIN 9021 washer M10 2x DIN 934 nut M10



HMS Prefabricated Component Inserts

Concrete inserts are supplied in standard types and sizes as shown on the tables above. Special design can also be made to suit application requirements

Product Code Description

HMS-GS - 3.5

Dead Load (kN)
Type

HMS-AV Special Restraint Channel - Product Details

Flat reinforced concrete roof tops can deform due to the effects of weather, thermal and mechanical loading. For this reason, reinforced concrete flat roofs are supported on sliding bearings on the lower walls. Brickwork wall claddings in front of these walls will not be able to absorb the deformations caused in the structure without being damaged. Brickwork walls that extend right up to the roof must not be connected on to the roof side walls.

A special restraint channel is the solution to this problem. A 28/15 channel that is welded with plates that are designed to be fixed on the load bearing beams with two connections can be used to restrain the brick walls. HWT-M wall ties are used to restrain the brick wall and can be positioned anywhere along the length of the channels.

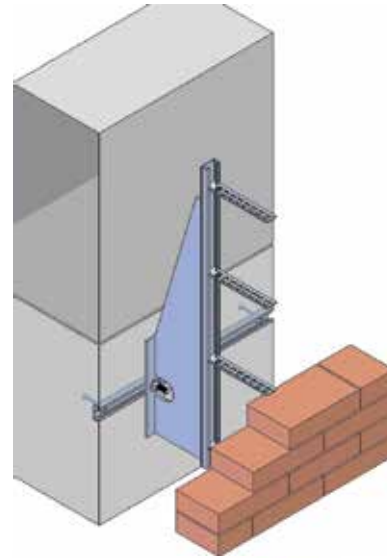

HMS-AV Special Restraint Channel

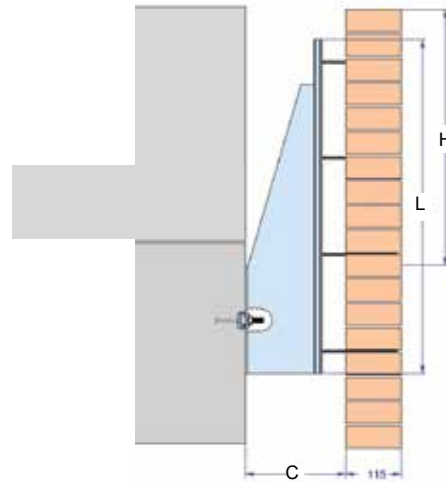

Product Code	Technical Details				
	Cavity	Length	Useful Height	Wall Tie Quantity	Wall Tie Types
	C (mm)	L (mm)	H (mm)	(pcs)	
HMS-AV-600-80	80	600	440-550	3	HWT-M-28-85
HMS-AV-600-90	90				HWT-M-28-120
HMS-AV-600-145	145				HWT-M-28-180
HMS-AV-850-80	80	850	650-800	4	HWT-M-28-85
HMS-AV-850-90	90				HWT-M-28-120
HMS-AV-850-145	145				HWT-M-28-180
HMS-AV-1100-80	80	1100	900-1000	5	HWT-M-28-85
HMS-AV-1100-90	90				HWT-M-28-120
HMS-AV-1100-145	145				HWT-M-28-180

HMS-AV Special Restraint Channel

This restraint channel is fixed on the concrete wall with anchor channels or expansion bolts. The offset size of the special channel is 75 mm. There are other sizes available upon request.

Product Code Description

HMS -AV -600 / 80

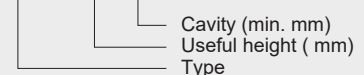

HWP Brickwork Windposts - Introduction

HWP Windposts are used in combination with suitable wall ties, to restrain brickwork walls against wind pressure and suction. The windposts are made from specially designed channels that have welded plates with slotted holes in order to be easily and securely fixed on to the reinforced concrete beams.

The windposts can be specially designed and manufactured suitable to withstand the wind loads on the project. The span distances of the channels may be arranged according to the structural integrity and the restrictions of the construction. Structural analysis must be made in view of these limitations. Applications and load requirements can be specifically designed and structural analyses prepared according to the specifications of the project.

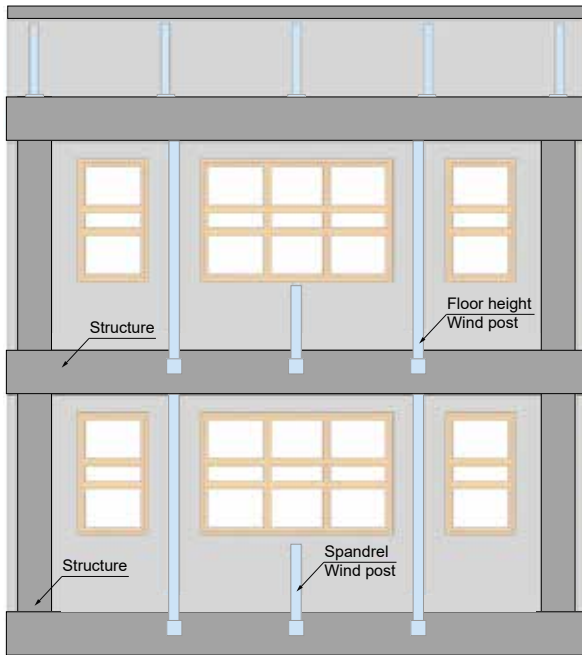

• Building Elevation with windpost positions

Windpost Channel Section Types

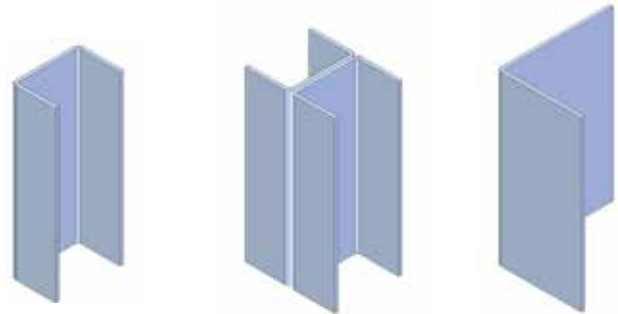

Windpost Restraining Tie Types

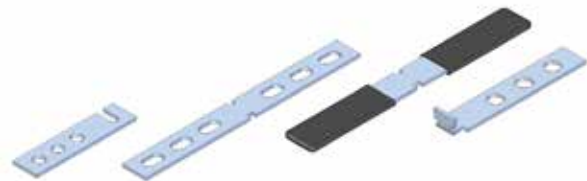

HWP-I Windpost System

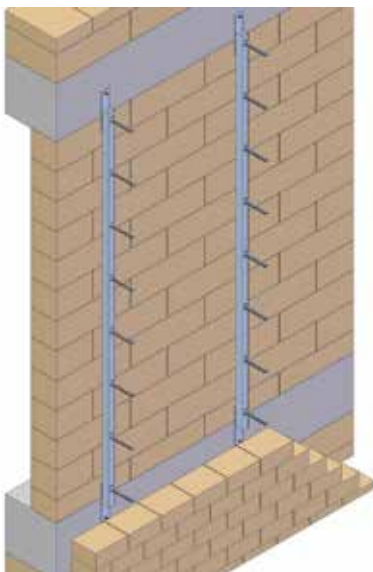

The **HWP-U** Windpost system is used for restraining the outer shell brick facing walls. The windpost channels have welded plates on both ends with slotted holes by which they can be fastened on to concrete beams at floor levels with bolts.

HWP-E Windpost System

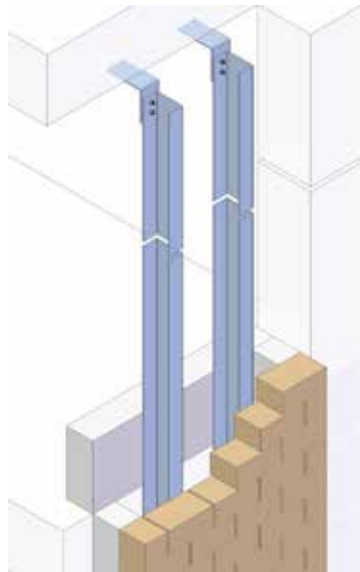

The **HWP-E** Windpost system is used for restraining the outer and inner shell brick facing walls. The windpost channels can be fixed on the beam ceiling and ground by L type brackets which will be fastened to the channels with hex bolts.

HWP-L Windpost System

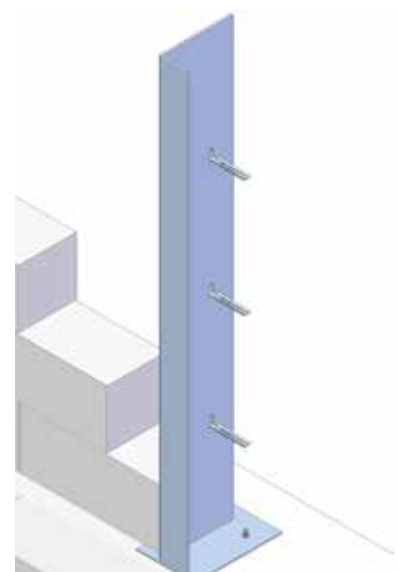

The **HWPS-L** Windpost system is used for restraining the block work constructed in the inner wall. The channels are positioned in between the block work to take the lateral loads. Outer wall brick facing can also be restrained to these channels.

HWP Brickwork Windpost Channels - Product Information

HWP-I Windpost Channel

- Channels span between floor beams and are fixed to the concrete load bearing beams with expansion bolts. Can also be installed on to cast in channels
- Corresponding wall ties are used to restrain the outer brick facing wall on to the channels. The wall ties slide through the slotted hole on the channels and lock after a 90 degree twist
- Designed wind loads are taken into consideration to determine the dimensions of the channels. Can be used for cavities between 70 - 205 mm

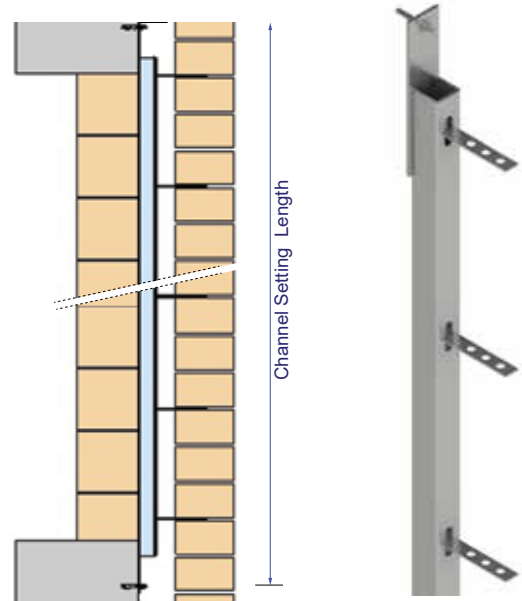
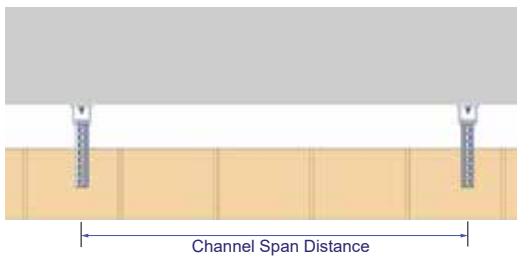

HWP-E Windpost Channel

- Channels span between floor beams and are fixed on to concrete beams with expansion bolts
- Corresponding wall ties with a loop are hooked on the channel lips for restraining the walls. The slotted hole version can also be manufactured to suit normal wall ties
- L angles are manufactured from 4 and 5 mm thick plates. Channels are manufactured on a project basis and any dimension is possible

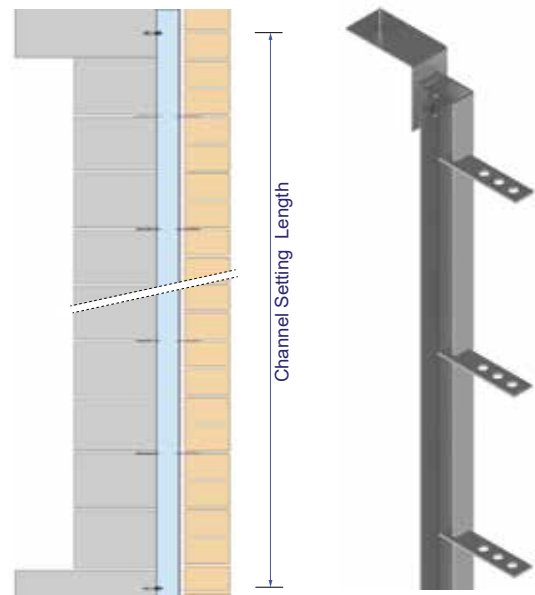
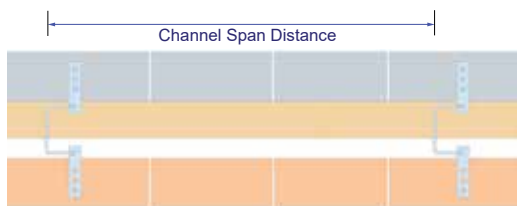

HWP-L Windpost Channel

- Channels are manufactured with welded plates at the ends of the channels. The channels are fixed on to the beam flooring with expansion bolts.
- Corresponding wall ties with a loop are hooked on the channel lips for restraining the walls. The slotted hole version can also be manufactured to suit the normal wall ties
- Channels are manufactured on a project basis and any dimension is possible

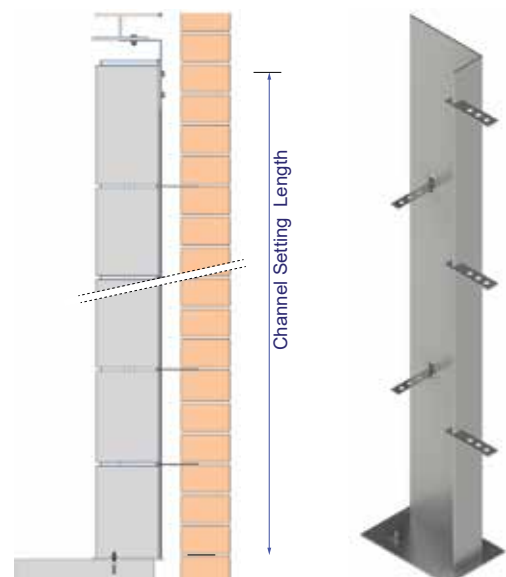
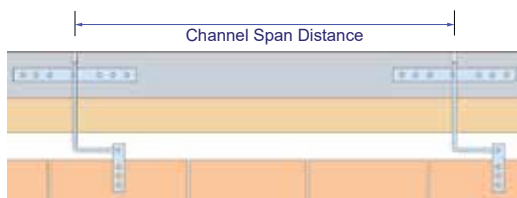

HMLS Brickwork Lintel Supports - Product Information

The **HMLS** Brickwork lintel supports are used for supporting brick structures above openings. The lintel supports can be designed and manufactured to suit a wide range of loadings and application circumstances. The majority of the lintel supports are specially designed and manufactured. Allowable loads are determined by structural calculations and local testing if required. **HMLS** Brickwork lintel supports are produced in stainless steel AISI 304 and AISI 316.

FIX-F Brickwork Support Bracket For Lintel Support

- Exposed fixing with HMS-F brickwork support brackets
- Welded support angles with lengths up to 1.5 metres available
- Load capacities of up to 10.5 kN

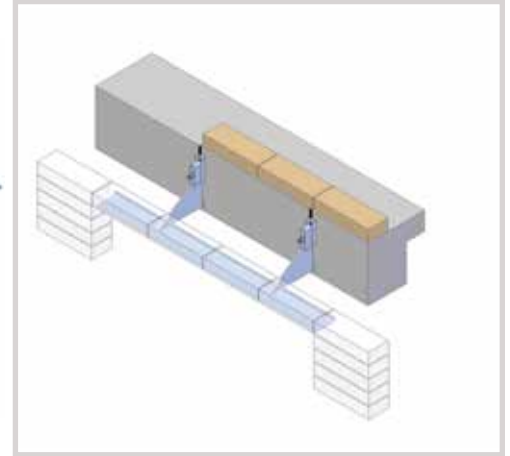
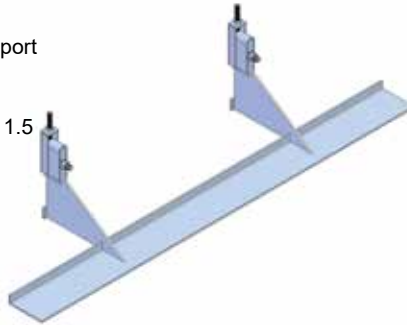

FIX-SV Brickwork Support Bracket For Lintel Support

- Concealed fixing where HMS-SV brackets are used for prefabricated Lintel component
- U type inserts or cast in channels are cast in the component and are fixed on the slot holes of the brickwork support
- Structural analysis of the prefabricated component must be made by the manufacture

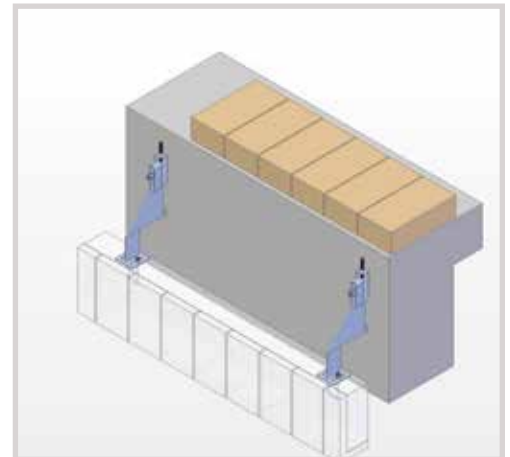

HMLS-T Lintel Support

- Concealed fixing where custom designed steel component used in combination with slotted holed plates to support bricks with reinforcement bars
- Minimum bearing of steel component on the wall surface is 150 mm
- Can be custom designed to fit various application requirements

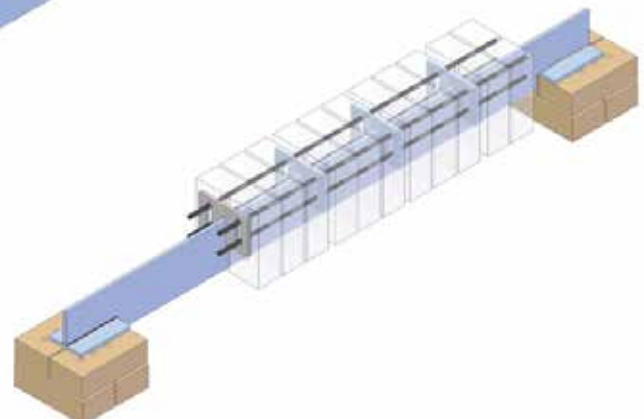
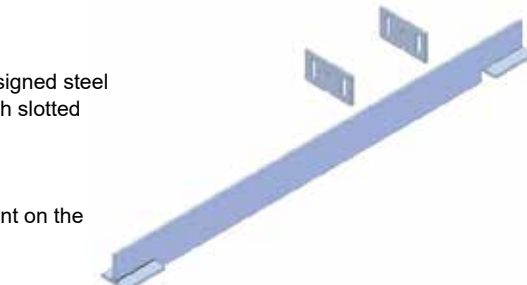

Apex Arch



Semi Circular Arch



HMLS Brickwork Lintel Supports - Product Information

HMLS-E Lintel Support Angle

- Exposed fixing with L angles are used for mounting bricks on top
- Can be placed on side wall as well as in between brickwork support brackets
- Minimum bearing on the wall surface is 95 mm
- Angle length available up to 2.2 metres and Max span of opening is 2.10 metres
- Technical details can be seen on page 47

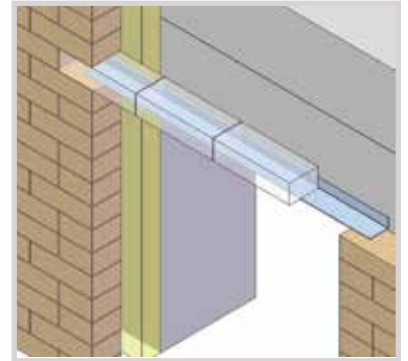

HMLS-C Lintel Support Angle With Hoops

- Concealed fixing where the L angles are used in combination with suspension hoops to support bricks lintel using reinforcement bars
- When determining the loads both the over laying and underlaying bricks must be taken into consideration
- Brick Lintel must be supported with scaffolding during fixing.
- Technical details can be seen on page 47

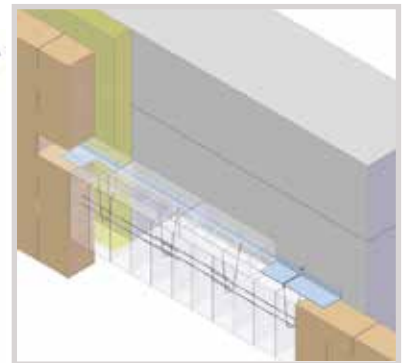
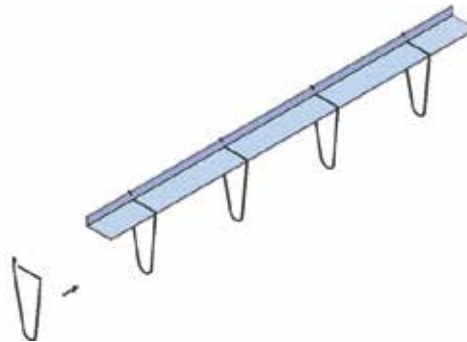

FIX-FV Lintel Support With Hoops

- Concealed fixing where the hoops are used in combination with HMS-FV support brackets to support underlaying bricks
- Angle length available up to 1.5 metres and load capacity up to 10.5 kN

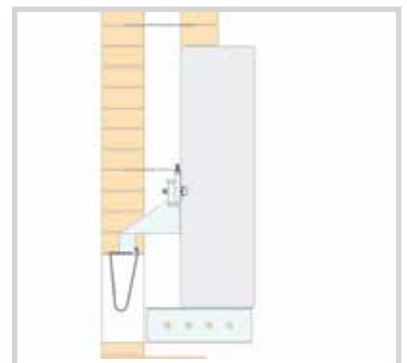

HMLS-HK Hoops For Lintel Suspension

- Hoops are special wires designed to fit support plates on the brackets or angles for the suspension of lintels
- Standart diameter os 4 and is available in different shapes and sizes to fit the application

Type L for L angles



Type B for single brackets

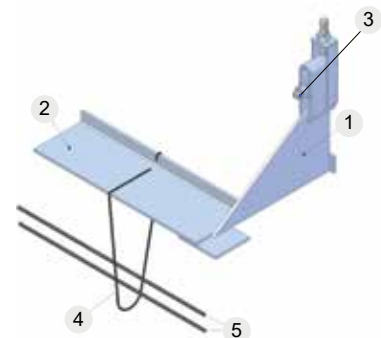

1. FIX-U Bracket
2. HMLS Angle
3. attachment to wall
4. HMS-HK Hoop
5. Reinforcement bars

HMLS Brickwork Lintel Supports - Technical Details

HMLS-E Lintel Support Angle

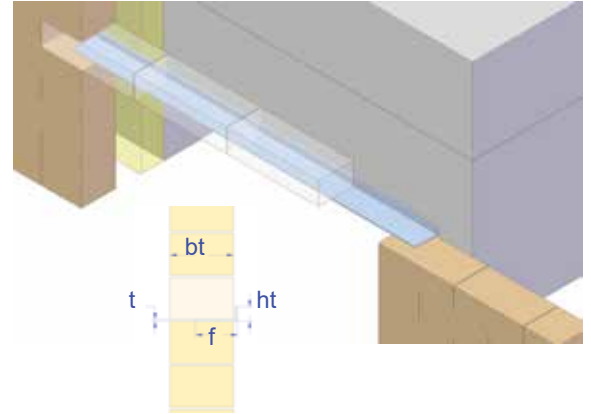
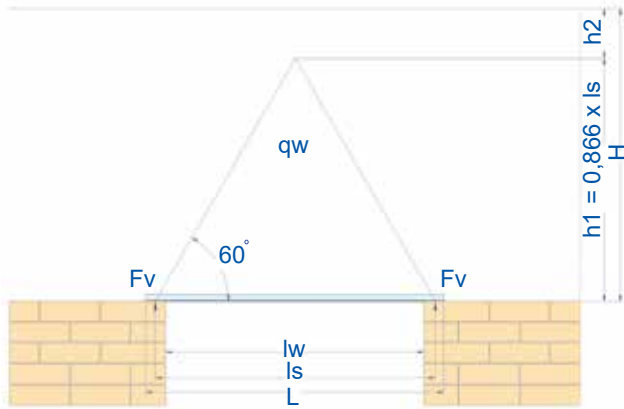

With Arch Action
in cases where $H > h$

lw (mm)	L (mm)	H < 1,00 m	H < 1,25 m	H < 1,50 m	H < 1,75 m	H < 2,00 m	H < 2,25 m	H > 2,25 m	h (m)
510	700	95x30x3	95x30x3	95x30x3	95x30x3	95x30x3	95x30x3	95x30x3	0,71
760	950	95x30x3	95x30x3	95x30x3	95x30x3	95x30x3	95x30x3	95x30x3	0,94
1010	1200	95x60x3	95x60x3	95x45x3	95x45x3	95x45x3	95x45x3	95x45x3	1,17
1260	1450	95x60x4	95x60x5	95x60x5	95x60x3	95x60x3	95x60x3	95x60x3	1,40
1510	1700	95x90x4	95x90x4	95x90x5	95x90x5	95x90x4	95x90x4	95x90x4	1,62
1760	1950	95x90x4	95x90x5	95x90x5	95x90x6	95x90x6	95x90x4	95x90x4	1,85
2010	2200	95x90x5	95x90x6	95x90x8	95x100x8	95x100x8	95x100x8	95x90x6	2,08

HMLS-C Lintel Support Angle with suspension loops

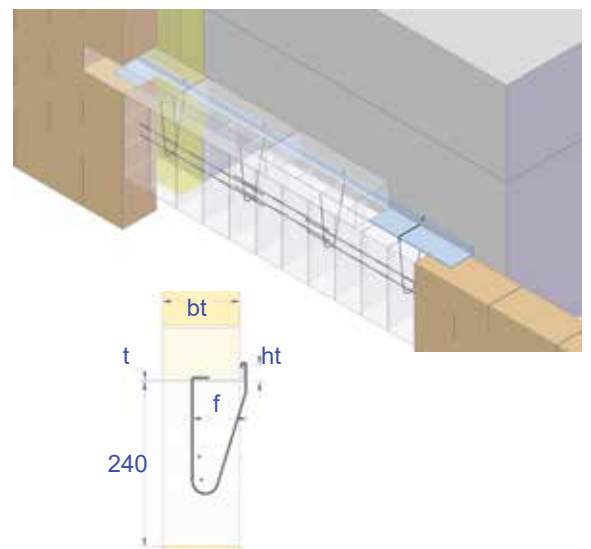
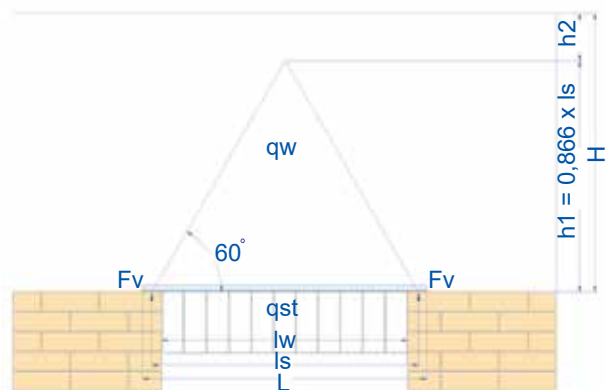

Loading on the lintel support

Without arc action:

load height = H [m]
 load $qw = H \times d \times \gamma$ [kN/m]
 static span $ls = lw + 2 \times \text{support length}/3$ [m]
 $M_{max} = qw \times ls^2/8$ [kNm]
 $V_{max} = qw \times ls/2$ [kN]

With arc action:

load height $h = 0.866 \times LS$ [m]
 load $qw = h \times d \times \gamma$ [kN/m]
 length of angle $L = lw + 2 \times \text{support length}/3$ [m]
 static span $ls = lw + 2 \times \text{support length}/3$ [m]
 $M_{max} = qw \times ls^2/12$ [kNm]
 $V_{max} = qw \times ls/4$ [kN]

HM-SW Precast Lintel Bracket - Product Information

HM-SW Lintel bracket



- Used for the support of lintel components on to standing outer walls
- Lintel brackets are cast in to components,
- Static calculation of the lintel must be made separately

Load (kN)	Product code	Angle width b (mm)	Wall thickness bt (mm)
3,5	SW-3,5-80	80	115
5,3	SW-5,3-80	80	115
6,8	SW-6,8-80	80	115
2,6	SW-2,6-60	60	90
3,9	SW-3,9-60	60	90
5,1	SW-5,1-60	60	90

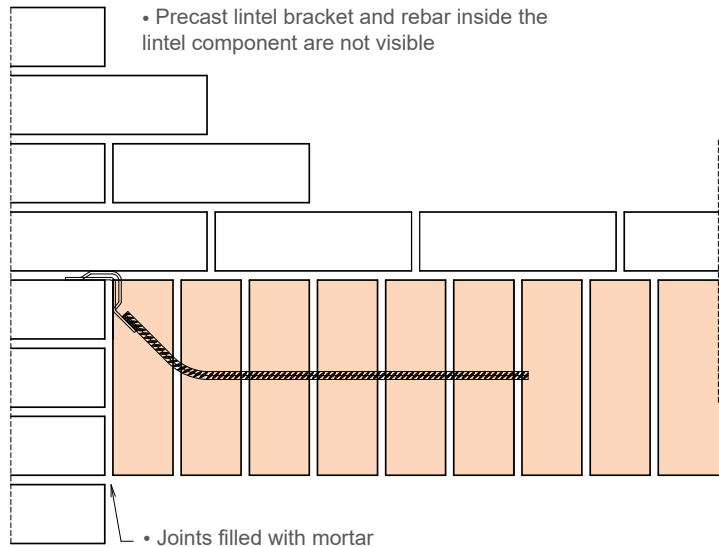
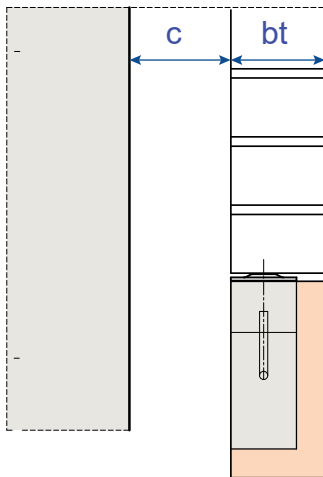

Load Calculation Principle with Arch action

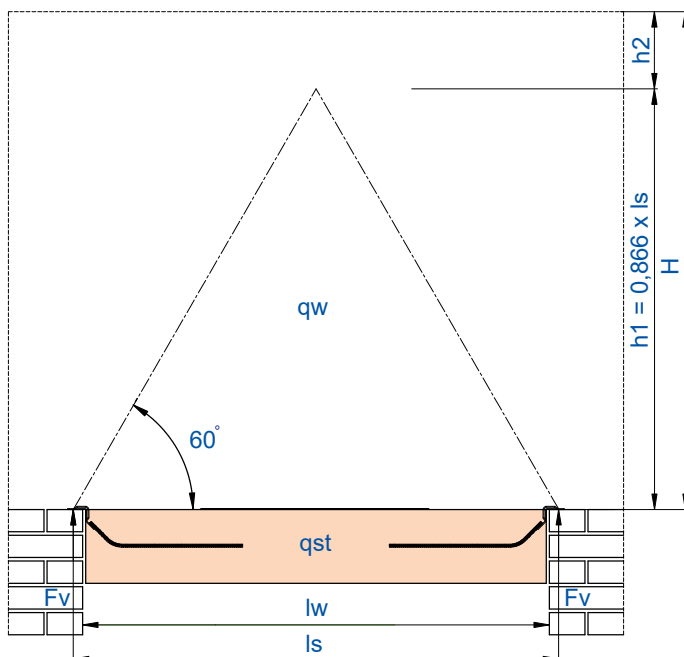

Loading on the lintel support

Load case 1: $h_2 < 25 \text{ cm}$ \Rightarrow without arc action

$$F_v = \frac{H * l_w * q_w}{2} + \frac{l_w * q_{st}}{2}$$

Fall 2: $h_2 \geq 25 \text{ cm}$ \Rightarrow with arc action

$$F_v = \frac{h_1 * l_s * q_w}{4} + \frac{l_w * q_{st}}{2}$$

Loading on brickwork

bt = 11,5 cm \rightarrow $q_w = 2,67 \text{ kN/m}^2$
 bt = 9,0 cm \rightarrow $q_w = 1,62 \text{ kN/m}^2$

Loading on Lintel

bt = 11,5 cm \rightarrow $q_{st} = 0,62 \text{ kN/m}$
 bt = 9,0 cm \rightarrow $q_w = 0,50 \text{ kN/m}$

HMP Brickwork Wall Tie Channels - Product Details

Brickwork wall tie channels and suitable wall ties are used in combination for restraining outer skin brickwork walls. This system ensures the durable and reliable connection of the brickwork wall easily and efficiently. The wall ties can be positioned anywhere along the length of the channel. Fixing is done by inserting the wall ties in to the slot of the channel and then turning them 90 degrees to effectively locking the wall tie in to the channel. There are different types of channels available that can be cast in and also surface mounted.

HMPR-25/15 Anchor Channel

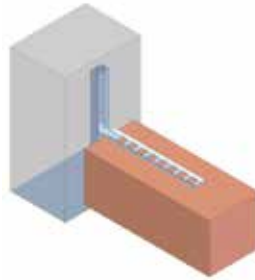

HMPR-28/15 & 38/17 Anchor Channel

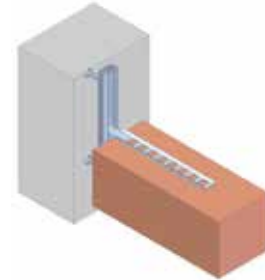

HMP-28/15 & 38/17 C Channels

- Surface fixing with expansion bolt on to reinforced concrete walls

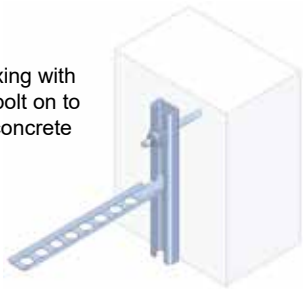

- Fixing on to metal studs with self tapping screws

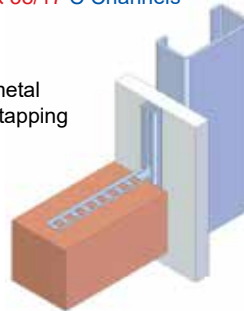

- Welding on to structural steel

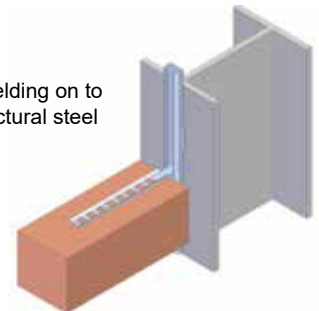

Product Code		Technical Details		
		Section Size (mm)	Allowable Pull Out Load At Distance Of 250 Mm all F (kN)	Wall Tie Type
<p>HBTR-25/15</p>  <p>HMPR-28/15 & HMPR-38/17</p> 	HMPR-25/15 Anchor Channel	25/15	1.2	HWT-M-28
	HMPR-28/15 Anchor Channel	28/15	3.0	
	HMPB-28/15 Surface Channel	28/15	3.0	
<p>HMPB-38/17</p> 	HMPR-38/17 Anchor Channel	38/17	4.5	HWT-M-38
	HMPB-38/17 Surface Channel	38/17	4.5	

HMP Brickwork Wall Tie Channels

Wall Tie Channels are supplied in 3 and 6 metre lengths as standard. Special lengths can be cut according to project requirements. Channels are available in stainless steel and galvanized steel.

Product Code Description

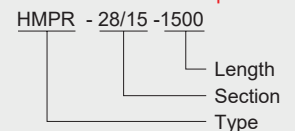

HWT-M Brickwork Wall Ties

The **HWT-M** Brickwork wall ties are used in combination with channels for restraining brickwork walls. The wall ties are inserted anywhere along the channel and pressed into the bearing joint mortar of the work at recommended distances.

The type of wall ties varies according to the corresponding channel type of 28/15 or 38/17 and in the overall length of the wall tie.



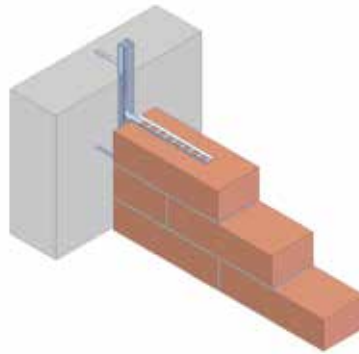

The **HWT-M** wall ties can be used to connect brick walls and outer shell brick facing on to reinforced concrete walls.

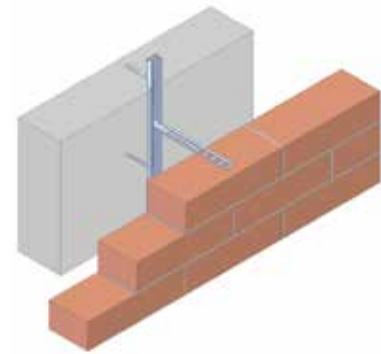

• Connection of brick walls to reinforced concrete walls.



• Connection of outer brick facing facades to reinforced concrete walls.

Product Code		Technical Details			
		Length	Size	Corresponding Channels	Wall Tie Head
		L (mm)	txw (mm)		
HWT-MS 	HWT-MS 28-85	85	2x26	HMPR-25/15	Suitable for 25/15 & 28/15 channel 
	HWT-MS 28-120	120		HMPR-28/15	
	HWT-MS 28-180	180		HMPB-28/15	
	HWT-MS 38-85	85	2x30	HMPR-38/15	
	HWT-MS 38-120	120		HMPB-38/15	
	HWT-MS 38-180	180			
HWT-ML 	HWT-ML 28-85	85	2x26	HMPR-25/15	Suitable for 38/17 channel 
	HWT-ML 28-120	120		HMPR-28/15	
	HWT-ML 28-180	180		HMPB-28/15	
	HWT-ML 38-85	85	2x30	HMPR-38/15	
	HWT-ML 38-120	120		HMPB-38/15	
	HWT-ML 38-180	180			
HWT-MT 	HWT-MT 28-85	85	2x26	HMPR-25/15	
	HWT-MT 28-120	120		HMPR-28/15	
	HWT-MT 28-180	180		HMPB-28/15	
	HWT-MT 38-85	85	2x30	HMPR-38/15	
	HWT-MT 38-120	120		HMPB-38/15	
	HWT-MT 38-180	180			

HWT Wall Ties

This brickwork support bracket has a single welded plate used for independent installation of each brick block. This bracket is used for closed surface elevation brick cladding.

Product Code Description

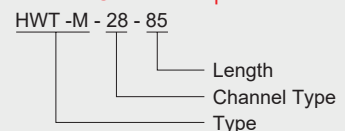

HRST Restraining Tie - Product Details



Brickwork walls are constructed of an outer shell which is thin and must be restrained against buckling. The wind loads must also be transferred on to the load bearing walls. Depending on the material used to construct the inner load bearing wall, suitable restraining ties are used in restraining the outer shell brickwork walls on to inner load bearing walls. **HRST** restraining ties can be securely and reliably used to restrain the brickwork walls against horizontal loads. These ties are made out of round steel and have wavy forms for embedding into mortar joints. There are two versions that are used for brickwork load bearing walls and concrete load bearing walls.

HRST-C Restraining Tie

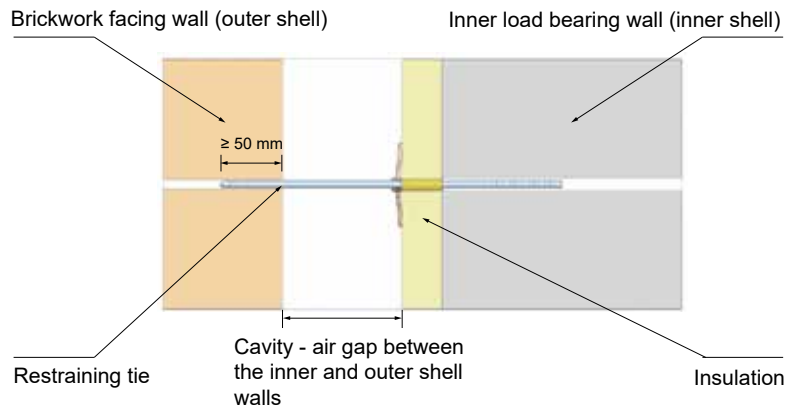
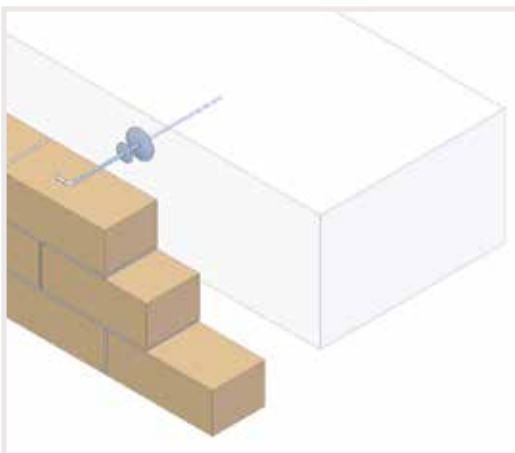

HRST-M Restraining Tie



Product Code	Technical Details					
	Length	Cavity	Diameter	Application Area		
	(mm)	(mm)	(mm)	Internal Wall	External Wall	
	HRST-M-225-4	225	up to 100	4.0	Brickwork wall	Brickwork Wall
	HRST-M-250-4	250	up to 125	4.0		
	HRST-M-275-4	275	up to 150	4.0		
	HRST-M-300-4	300	up to 175	4.0		
	HRST-M-340-4	340	up to 215	4.0		
	HRST-C-160-4	160	up to 25	4.0	Concrete B15	Brickwork Wall
	HRST-C-180-4	180	up to 45	4.0		
	HRST-C-210-4	210	up to 75	4.0		
	HRST-C-250-4	250	up to 115	4.0		
	HRST-C-275-4	275	up to 140	4.0		
	HRST-C-300-4	300	up to 165	4.0		
	HRST-C-320-4	320	up to 185	4.0		
	HRST-C-350-4	350	up to 200	4.0		

HRST Restraining Ties

The restraining ties are used for restraining the brick facing outer shell walls against wind pressure and suction

Product Code Description

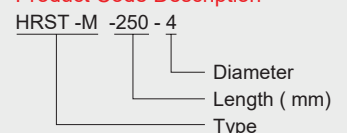

CWMT Brickwork Corrugated Wall Ties - Product Information

CWMT-D Brickwork Wall Tie



- Corrugated tie provides multiple drips to prevent moisture bridging cavity
- Provides lateral restraint for wind pressure & suction on brick work without transferring loads on to insulation
- Fixed on to 38/17 cast-in or surface fixed channels
- Positioning any where along the length of the channels
- Available in lengths between 75 and 250 mm
- Tensile loading is 0.7 kN per 600 mm screw centres

CWMT-D wall ties fixed on surface mounted C channels

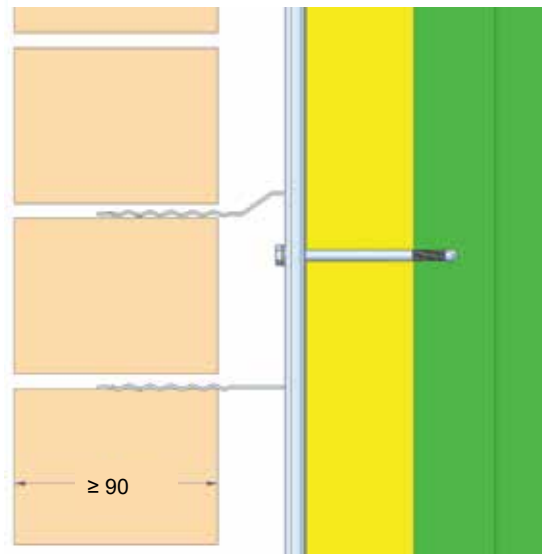

Product Code	Length
CMWT-D-75	75
CMWT-D-100	100
CMWT-D-125	125
CMWT-D-150	150
CMWT-D-200	200
CMWT-D-225	225
CMWT-D-250	250

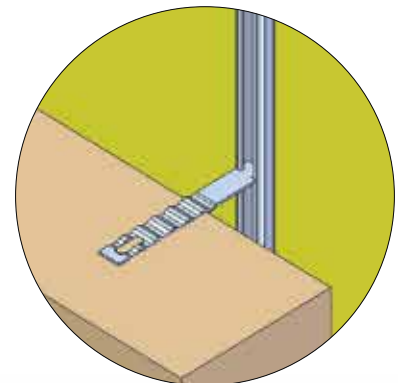
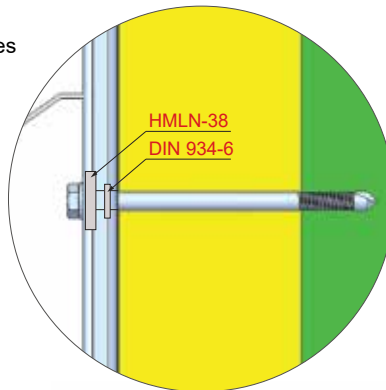

HJT Self Tabbing Screw



- Self tapping screws with drill adaptor used for quick and easy fixing of surface channels on to metal studs

Product Code	Dimensions	Description	Insulation Thickness
For steel sections 1.5-6 mm thickness			
HJT-3-70	5.5x70	Un-washed	20-50
HJT-3-90	5.5x90		40-70
HJT-3-110	5.5x110		60-90
HJT3-130	5.5x130		80-110
For steel sections 1.5-6 mm thickness			
HJT2-120	6x120	Washed	55-105
HJT2-140	6x140		75-125
HJT2-160	6x160		95-145

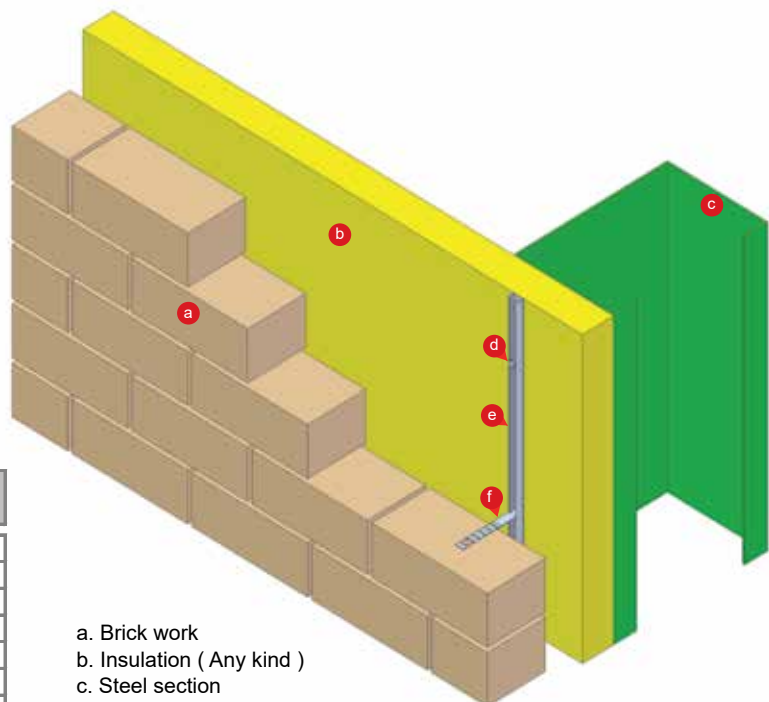

- a. Brick work
- b. Insulation (Any kind)
- c. Steel section
- d. HJT Self tabbing screws
- e. HMPD-38/17 Surface channel
- f. CWMT-D Corrugated wall tie

HRST Restraining Tie - Product Details

CWMT-C Brickwork Wall Tie

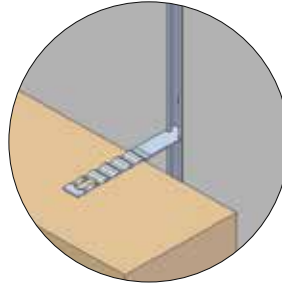

CWMT-D wall ties fixed on cast in channels

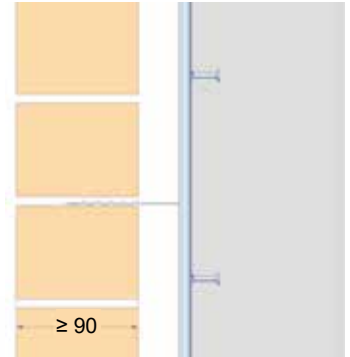

- Fixed on to 38/17 cast-in or surface fixed channels
- Positioning any where along the length of the channels
- Available in lengths between 75 and 250 mm
- Tensile loading is 1.0 kN

Product Code	Length
CMWT-C-75	75
CMWT-C-100	100
CMWT-C-125	125
CMWT-C-150	150
CMWT-C-200	200
CMWT-C-225	225
CMWT-C-250	250

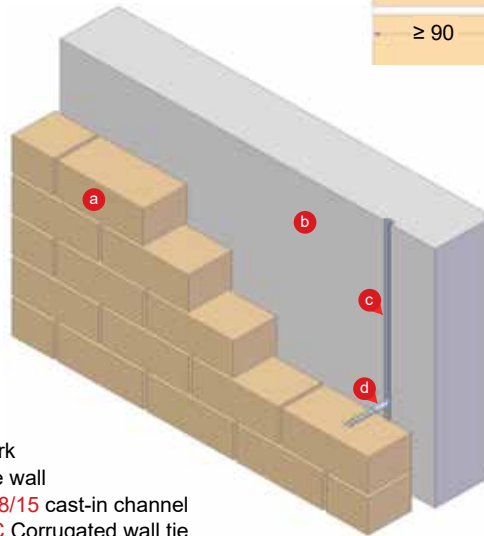

- a. Brick work
- b. Concrete wall
- c. **HMPR-28/15** cast-in channel
- d. **CMWT-C** Corrugated wall tie

CWMT-B Brickwork Wall Tie

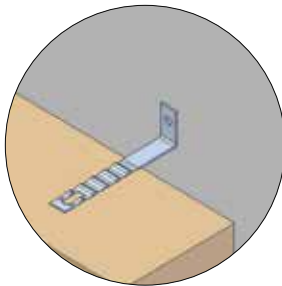

CWMT-B wall ties fixed on cast in channels

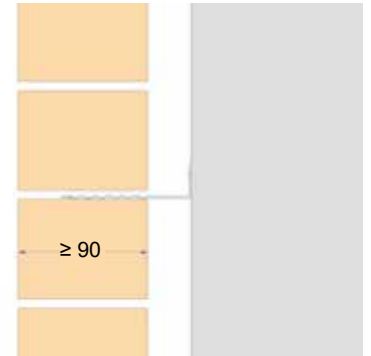

- Fixed on to concrete and brickwork walls with facade plugs
- Can be riveted or welded on to structural steel as well
- Available in lengths between 75 and 250 mm
- Tensile loading is 1.0 kN

Product Code	Length
CMWT-B-75	75
CMWT-B-100	100
CMWT-B-125	125
CMWT-B-150	150
CMWT-B-200	200
CMWT-B-225	225
CMWT-B-250	250

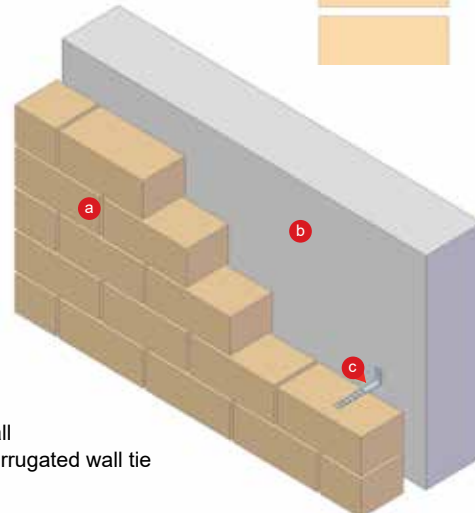

- a. Brick work
- b. Concrete wall
- c. **CMWT-B** Corrugated wall tie

CWMT Brickwork Corrugated Cavity Wall Ties - Product Information

CWMT-A Brickwork Wall Tie

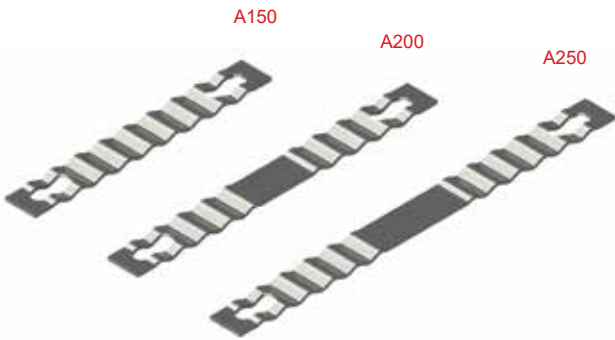

- Fixed on to both inner and outer shell walls with mortar
- Quick and easy to install
- Available in 150 , 200 and 250 mm
- Can be supplied in stainless steel and galvanized steel

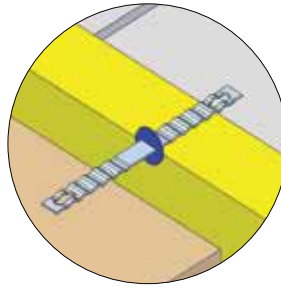

CWMT-A wall ties connected between inner and outer shell walls

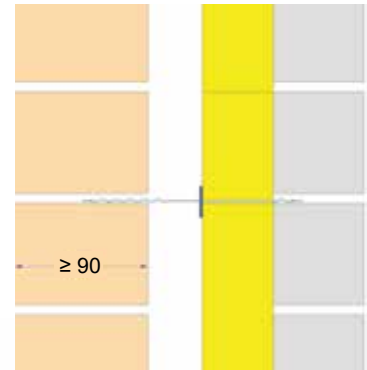

Product Code	Length
CMWT-A-150	150
CMWT-A-200	200
CMWT-A-250	250

- a. Brick work
b. Concrete wall
c. CWMT-A Corrugated cavity tie

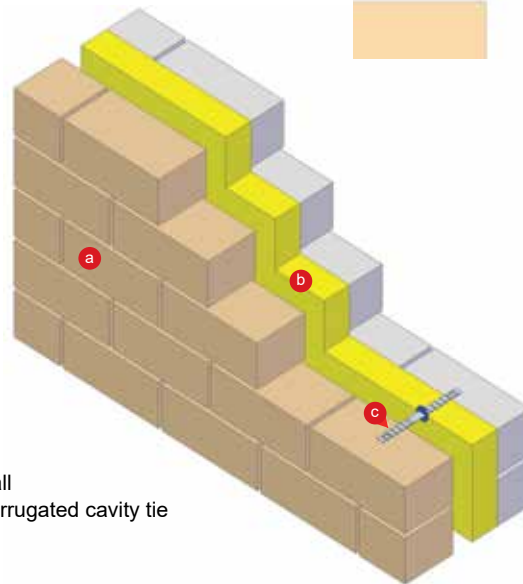

FMWT Brickwork Wall Ties For Expansion Joints - Product Information

FMWT Brickwork Wall Ties For Expansion Joints

- Wall ties supplied with debonding sleeves
- Used on expansion joints where the debonding sleeves allow movement
- Available to fit the range of the CWMT wall ties



Product Code	Length
FMWT-A-225	225

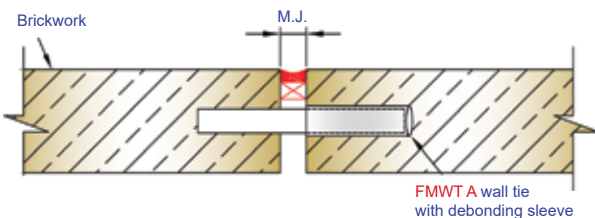

Product Code	Length
FMWT-B-125	125

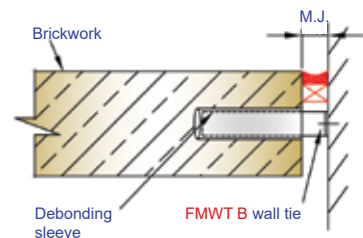

Product Code	Length
FMWT-C-28-125	125
FMWT-C-38-125	125

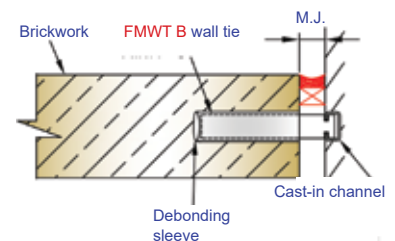

HMHR Brickwork Head Restraints - Product Information

HMHR Brickwork head restraints are specifically designed parts for restraining brickwork below horizontal soft joints by attaching the brickwork to the structure without restricting differential movement. These items are available in stainless steel AISI 304 and AISI 316.

HMHR-C Cavity Head Restraint

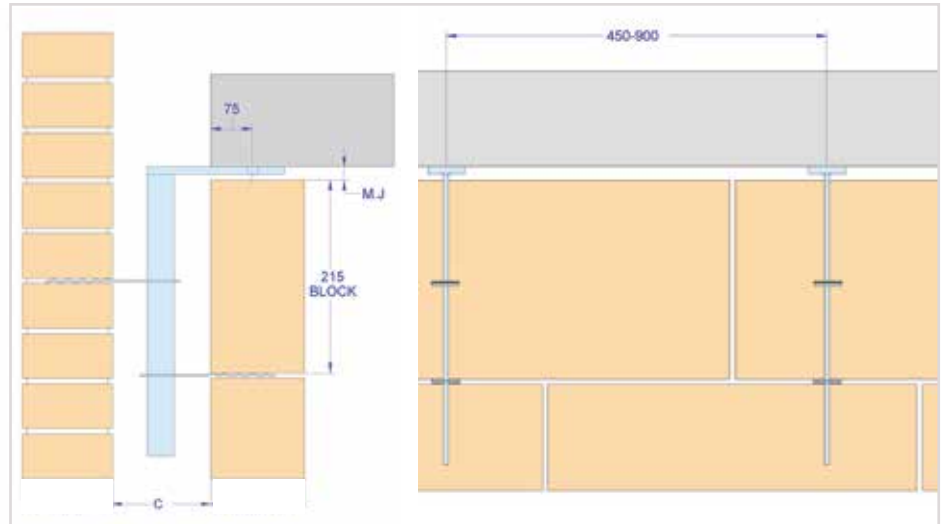
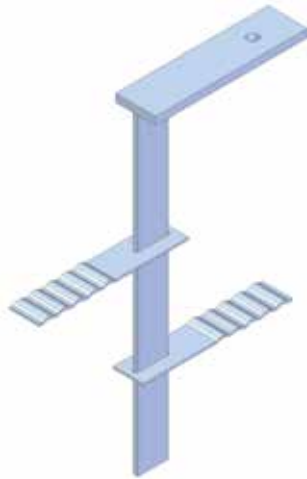

- Corrugated ties prevent dripping and reduces moisture bridging cavity
- Provide lateral restraint for inner and outer wall brick facing
- Service load is 1 kN
- Available in stainless steel and galvanized steel
- Movement joint maximum 25 mm
- Other sizes are available to order

Product Code	Cavity
HMHR-C-75	75
HMHR-C-125	125
HMHR-C-175	175
HMHR-C-225	225

HMHR-H Hidden Head Restraint

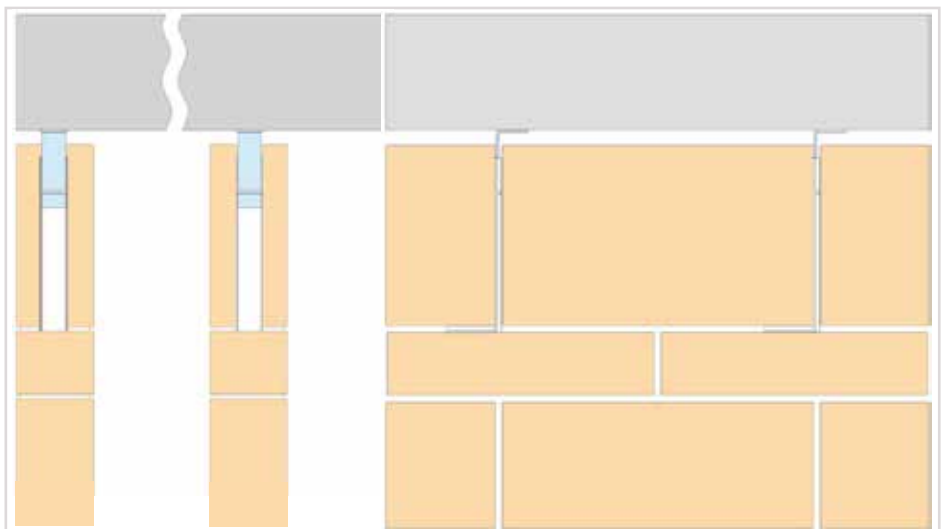

- Hidden head restraint used for areas where aesthetics are a consideration
- Provides vertical tolerance and differential movement with a debonding sleeve
- Vertical joint must be mortar filled
- Available in stainless steel and galvanized steel
- Movement joint maximum 25 mm
- Other sizes are available to order

Product Code	Cavity
HMHR-H-75	75
HMHR-H-125	125
HMHR-H-175	175
HMHR-H-225	225

HMHR Brickwork Head Restraints - Product Information

HMHR-E Exposed Head Restraint

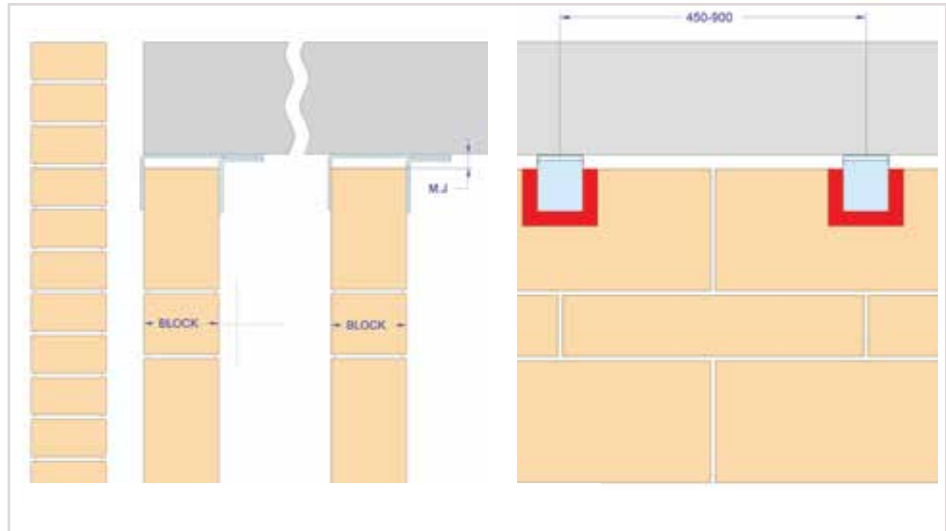
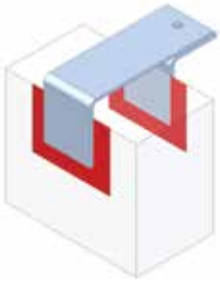

- Exposed head restraint for inner wall
- Provides vertical tolerance and differential movement with a debonding sleeve
- Vertical joint must be mortar filled

Product Code	Cavity
HMHR-E-75	75
HMHR-E-125	125
HMHR-E-175	175
HMHR-E-225	225

HMHR-E Exposed Head Restraint



- Exposed head restraint for inner wall
- Provides vertical tolerance and differential movement with a debonding sleeve
- Vertical joint must be mortar filled

Product Code	Cavity
HMHR-E-75	75
HMHR-E-125	125
HMHR-E-175	175
HMHR-E-225	225

FIX Support Bracket Connections Methods to Concrete

Fixing Method with HMPR Anchor channels

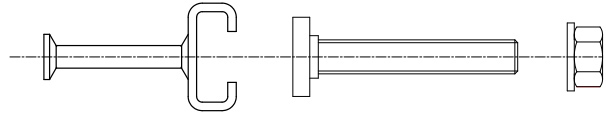
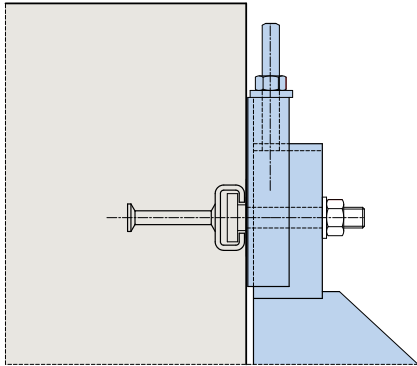

Recommended loads per FIX Bracket

Anchor channel types	Short length L = 15 - 25 cm		Length length L > 25 cm		T head bolt Types
	F (kN)	F _{Rd} (kN)	F (kN)	F _{Rd} (kN)	
28/15	3,5	4,9	3,0	4,2	M10-M12
38/17	7,0	9,8	4,5	6,3	M10-M16
38/17K	7,0	9,8	7,0	9,8	M10-M16
40/25	8,0	11,2	6,0	8,4	M12-M16
49/30	12,0	16,8	10,0	14,0	M16-M20
54/33	22,0	30,8	22,0	30,8	M16-M20

- Recommended loads are determined according to Technşcal Approval Z-21.4-1878
- Calculated accordin to $F_{Rd} = 1,4 \times F$

Fixing Method with HB Anchor bolts

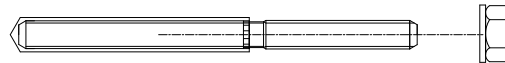
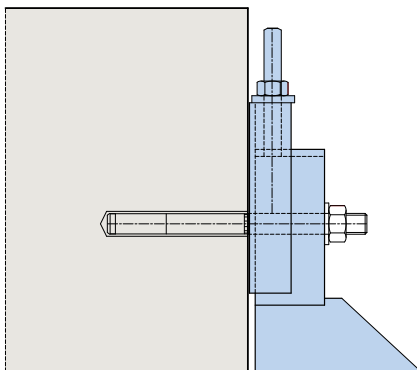

Recommended Anchor bolt types

Anchor bolt Types	Load category	Load category	Load category
	3,5 kN	7,0 kN	10,5 kN
HBZ Through bolt	HBZ-12/145 M12x145	HBZ-12/145 M12x145	HBZ-16/185 M16x185
HB07 Chemical bolt	HB07-12/190 M12x190	HB07-12/190 M12x190	HB07-16/210 M16x210

- The load capacity of anchor bolts depends on many factors such as concrete strength class, projection etc. and must be verified for each case.

Fixing Method with HDA Strap anchor

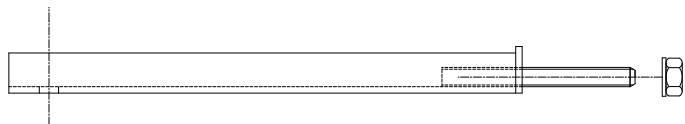
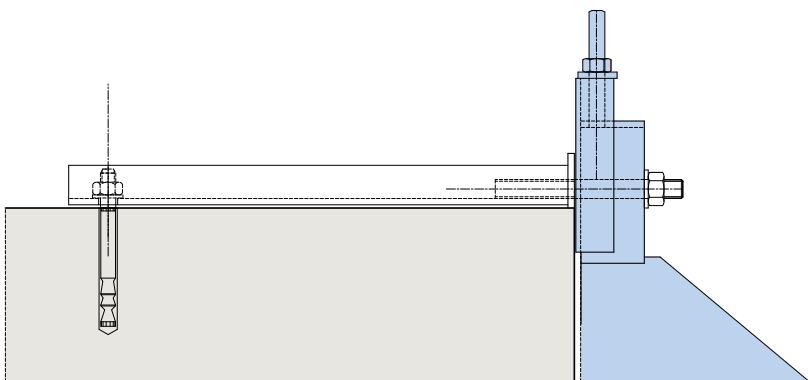

HDA Strap anchor

Product code	Load 3,5 kN	Length (mm)	Corresponding Anchor bolt
HDA-3,5	3,5 kN	320	HBZ-12/135 HB07-12/160
HDA-7,0	7,0 kN	320	HBZ-12/135 HB07-12/160

- Load capacities must be checked for each case.

HM-GA Scaffolding Anchors - Product Details

HM-GA -Q Scaffolding Anchor

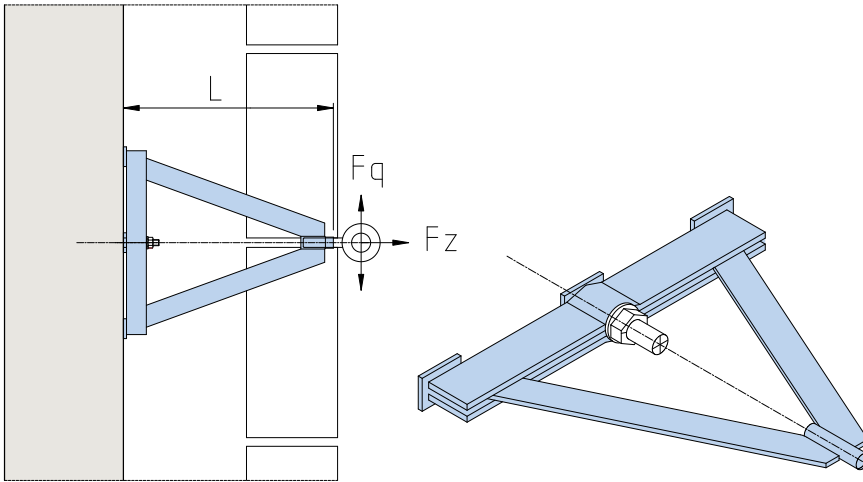

HM-GA-Q	L(mm)	Fz / Fq (kN)
GA - Q - 160	160	5,5 / 1,8
GA - Q - 180	180	
GA - Q - 200	200	
GA - Q - 220	220	
GA - Q - 240	240	
GA - Q - 260	260	
GA - Q - 280	280	

HM-GA -Z Scaffolding Anchor

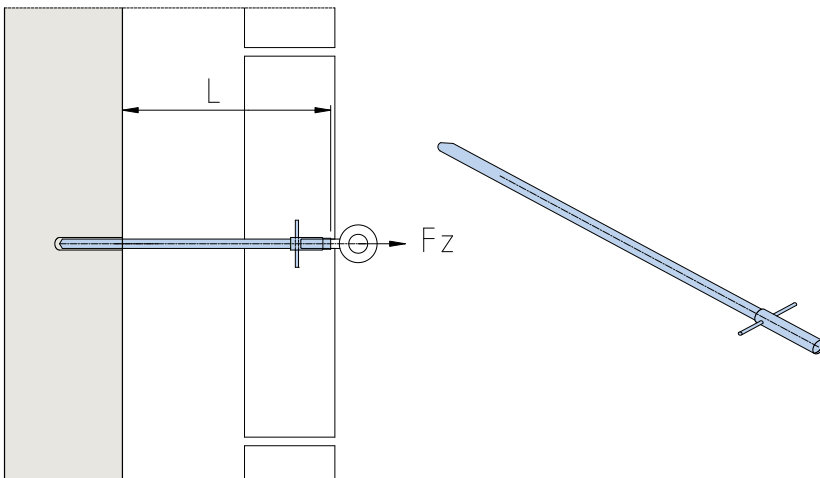

HM-GA-Z	L(mm)	Fz (kN)
GA - Z - 160	160	5,5
GA - Z - 180	180	
GA - Z - 200	200	
GA - Z - 220	220	
GA - Z - 240	240	
GA - Z - 260	260	
GA - Z - 280	280	

HM-GA -H Scaffolding Anchor

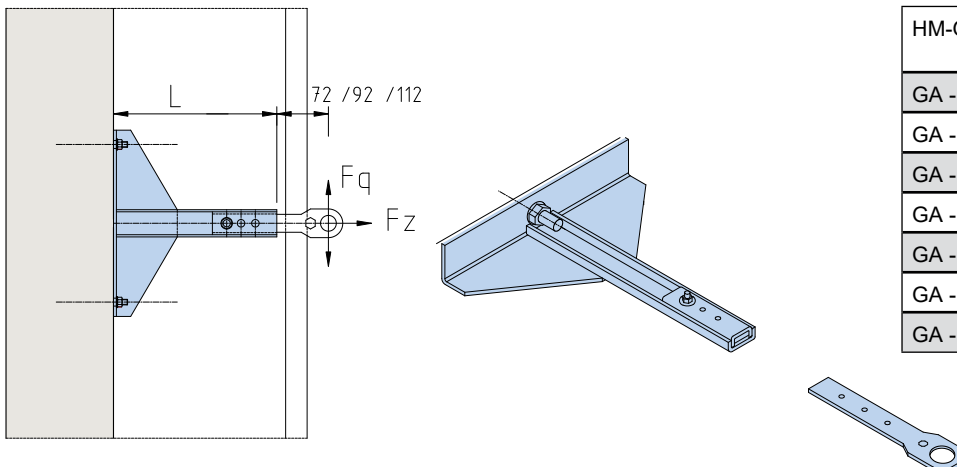

HM-GA-H	L(mm)	Fz / Fq (kN)
GA - H - 160	160	3,5 / 2,0
GA - H - 180	180	
GA - H - 200	200	
GA - H - 220	220	
GA - H - 240	240	
GA - H - 260	260	
GA - H - 280	280	

References

Project: Shopping Centre Camp
Location: Lintfort, Germany

Cladding area: 1.800 sqm



Project: Finance Tax office
Location: Solingen, Germany

Cladding area: 1.300 sqm



Project: Vista dalla piazza,
Location: Balzano, Italy

Cladding area: 1.800 sqm



Project: Bäckerbreitengang
Location: Hamburg, Germany

Cladding area: 800 sqm



Project: Pier 6,
Location: Bremerhaven, Germany

Cladding area: 1.000 sqm



Project: Bach private housing
Location: Switzerland

Cladding area: 300 sqm



References

Project: Bosmos office flats
Location: Switzerland
Cladding area: 2.250 sqm



Project: Wardalls Grove
Location: United Kingdom



Project: Rochester Riverside
Location: United Kingdom



Project: Rublevo Housing project
Location: Moscow, Russia



Project: Marinat Residence
Location: United Arab Emirates



Project: Sabanci University
Location: Istanbul, Turkey





Notes

Notes

A large grid of graph paper for taking notes. The grid consists of 30 columns and 40 rows of small squares, providing a structured area for writing or drawing.



Notes



HAZ PAZARLAMA İÇ & DIŞ TİC. A.Ş.
İçerenköy Mh. Çayır Cd. Özce Center
No:3 K:12 34752 Ataşehir
İstanbul, TÜRKİYE
Tel : +90 (0) 216 410 72 06
Fax : +90 (0) 216 410 71 41
www.hazpazarlama.com
hazpazarlama@hazgrp.com

HAZ INTERNATIONAL LTD.
154 Great North Road Hatfield
Herts. AL9 5JN England
Tel : +44 (0) 1707 - 260 180
Fax : +44 (0) 1707 - 260 190
www.hazuk.co.uk
haz@hazuk.co.uk

HAZ EGYPT LTD
Villa no.29-Third Floor.St.no.270
New Maadi, Cairo, Egypt
Tel : +20 (2) 2447 09 85
www.hazeg.com
info@hazeg.com

HAZ METAL SANAYİ VE TİCARET A.Ş.
Şehit Er Çıracı Caddesi No. 10
Akçay Sanayi Bölgesi 31200 İskenderun
Hatay, TÜRKİYE
Tel : +90 (0) 326 626 20 50
Fax : +90 (0) 326 626 20 45
www.hazmetal.com
info@hazmetal.com

HAZ MARBLE INDUSTRY & TRADE LLC
First Gulf Building Corniche Street
2nd Floor, Flat No. 202 P.O. Box 5721
Abu Dhabi, United Arab Emirates
Tel : +971 (0) 2 622 07 00
Fax : +971 (0) 2 622 17 00
www.hazuae.ae
hazuae@hazmarbleuae.ae

HAZ MARBLE QATAR WLL
P.O.BOX 31296 C-Ring road
Doha, Qatar
Tel : +974 (4) 467 26 13-47
Fax : +974 (4) 467 47 49
www.hazqatar.com
hazdoha@hazqatar.com

HAZ METAL DEUTSCHLAND GmbH
Leonhard Karl Strasse 29
97877 Wertheim, Germany
Tel : +49 (0) 9342 93590
Fax : +49 (0) 9342 935929
www.hazmetal.de
info@hazmetal.de

HAZ ASIA PACIFIC PTE LTD
Blk 22 Woodlands Link #01-65
Singapore 738734
Tel: +65 6853 7681
Fax: +65 6752 9582
www.hazapac.com
info@hazapac.com

HAZ RUS LTD
117036, UI, Profsoyuznaya Dom 3 (office 531)
Moscow, Russian Federation
Tel : +7 (926) 672 31 84
info@hazrus.ru
www.hazrus.ru



Always at the forefront of fixing technology, HAZ METAL has earned a reputation as the leaders in fixing systems innovation and is regarded as the one to follow. HAZ METAL fixing systems of today become the standard of tomorrow.

HAZ METAL combines the very latest international technology with its own research and development team to establish a technical excellence within the industry. HAZ METAL readily embraces the responsibility of a major producer and shares its expertise with problem solving solutions.