

Approval body for construction products
and types of construction

Bautechnisches Prüfamt

An institution established by the Federal and
Laender Governments



European Technical Assessment

ETA-17/0549
of 2 August 2024

English translation prepared by DIBt - Original version in German language

General Part

Technical Assessment Body issuing the
European Technical Assessment:

Deutsches Institut für Bautechnik

Trade name of the construction product

HAZ METAL - Anchor Channel HMPR

Product family
to which the construction product belongs

Anchor channels

Manufacturer

HAZ Metal Deutschland GmbH
Alfred-Zippe-Straße 1
97877 Wertheim

Manufacturing plant

HAZ Metal AS Iskenderun Türkiye

This European Technical Assessment
contains

35 pages including 3 annexes which form an integral part
of this assessment

This European Technical Assessment is
issued in accordance with Regulation (EU)
No 305/2011, on the basis of

EAD 330008-03-0601, Edition 06/2021

This version replaces

ETA-17/0549 issued on 12 November 2019

The European Technical Assessment is issued by the Technical Assessment Body in its official language. Translations of this European Technical Assessment in other languages shall fully correspond to the original issued document and shall be identified as such.

Communication of this European Technical Assessment, including transmission by electronic means, shall be in full. However, partial reproduction may only be made with the written consent of the issuing Technical Assessment Body. Any partial reproduction shall be identified as such.

This European Technical Assessment may be withdrawn by the issuing Technical Assessment Body, in particular pursuant to information by the Commission in accordance with Article 25(3) of Regulation (EU) No 305/2011.

Specific part

1 Technical description of the product

The HAZ METAL - Anchor Channel HMPR is a system consisting of C-shaped channel profile of carbon steel or stainless steel and at least two metal anchors non-detachably fixed to the channel back and channel bolts.

The anchor channel is embedded surface-flush in the concrete. HAZ METAL channel bolts with appropriate hexagon nuts and washers are fixed to the channel.

The product description is given in Annex A.

2 Specification of the intended use in accordance with the applicable European Assessment Document

The performances given in Section 3 are only valid if the anchor channel is used in compliance with the specifications and conditions given in Annex B.

The verifications and assessment methods on which this European Technical Assessment is based lead to the assumption of a working life of the anchor channel of at least 50 years. The indications given on the working life cannot be interpreted as a guarantee given by the producer, but are to be regarded only as a means for choosing the right products in relation to the expected economically reasonable working life of the works.

3 Performance of the product and references to the methods used for its assessment

3.1 Mechanical resistance and stability (BWR 1)

Essential characteristic	Performance
Characteristic resistance under tension load (static and quasi-static loading)	
- Resistance to steel failure of anchors	$N_{Rk,s,a}$ see Annex C1
- Resistance to steel failure of the connection between anchors and channel	$N_{Rk,s,c}$ see Annex C1
- Resistance to steel failure of channel lips and subsequently pull-out of channel bolt	$N_{Rk,s,l}^0 ; s_{l,N}$ see Annex C1
- Resistance to steel failure of channel bolt	$N_{Rk,s}$ see Annex C2
- Resistance to steel failure by exceeding the bending strength of the channel	S_{max} see Annex A5 $M_{Rk,s,flex}$ see Annex C1
- Maximum installation torque to avoid damage during installation	$T_{inst,g} ; T_{inst,s}$ see Annex B4 and B5
- Resistance to pull-out failure of the anchor	$N_{Rk,p}$ see Annex C3
- Resistance to concrete cone failure	h_{ef} see Annex B3 $k_{cr,N} ; k_{ucr,N}$ see Annex C3
- Minimum edge distances, spacing and member thickness to avoid concrete splitting during installation	s_{min} see Annex A5 $c_{min} ; h_{min}$ see Annex B3
- Characteristic edge distance and spacing to avoid splitting of concrete under load	$s_{cr,sp} ; c_{cr,sp}$ see Annex C3
- Resistance to blowout failure - bearing area of anchor head	A_h see Annex A4

Continued Table 3.1:

Essential characteristic	Performance
<p>Characteristic resistance under shear load (static and quasi-static loading)</p> <ul style="list-style-type: none"> - Resistance to steel failure of channel bolt under shear loading without lever arm - Resistance to steel failure by bending of the channel bolt under shear load with lever arm - Resistance to steel failure of channel lips, steel failure of connection between anchor and channel and steel failure of anchor (shear load in transverse direction) - Resistance to steel failure of connection between channel lips and channel bolt (shear load in longitudinal channel axis) - Factor for sensitivity to installation (longitudinal shear) - Resistance to steel failure of the anchor (longitudinal shear) - Resistance to steel failure of connection between anchor and channel (longitudinal shear) - Resistance to concrete pry-out failure - Resistance to concrete edge failure 	<p>$V_{Rk,s}$ see Annex C6</p> <p>$M_{Rk,s}^0$ see Annex C7</p> <p>$V_{Rk,s,l,y}^0 ; S_{l,V} ; V_{Rk,s,c,y} ; V_{Rk,s,a,y}$ see Annex C4</p> <p>$V_{Rk,s,l,x}$ see Annex C5</p> <p>γ_{inst} see Annex C5</p> <p>$V_{Rk,s,a,x}$ see Annex C5</p> <p>$V_{Rk,s,c,x}$ see Annex C5</p> <p>k_g see Annex C4</p> <p>$k_{cr,V} ; k_{ucr,V}$ see Annex C4</p>
<p>Characteristic resistance under combined tension and shear load (static and quasi-static load)</p> <ul style="list-style-type: none"> - Resistance to steel failure of the anchor channel 	<p>$k_{13} ; k_{14}$ see Annex C8</p>
<p>Characteristic resistance under fatigue tension loading</p> <ul style="list-style-type: none"> - Fatigue resistance to steel failure of the whole system (continuous or tri-linear function, test method A1, A2) - Fatigue limit resistance to steel failure of the whole system (test method B) - Fatigue resistance to concrete related failure (exponential function, test method A1, A2) - Fatigue limit resistance to concrete related failure (test method B) 	<p>$\Delta N_{Rk,s,0,n}$ see Annex C10</p> <p>$\Delta N_{Rk,s,0,\infty}$ see Annex C12</p> <p>$\Delta N_{Rk,c,0,n} ; \Delta N_{Rk,p,0,n}$ see Annex C11</p> <p>$\Delta N_{Rk,c,0,\infty} ; \Delta N_{Rk,p,0,\infty}$ see Annex C12</p>
<p>Displacements (static and quasi-static load)</p>	<p>$\delta_{N0} ; \delta_{N\infty}$ see Annex C9</p> <p>$\delta_{V,y,0} ; \delta_{V,y,\infty} ; \delta_{V,x,0} ; \delta_{V,x,\infty}$ see Annex C9</p>

English translation prepared by DIBt

3.2 Safety in case of fire (BWR 2)

Essential characteristic	Performance
Reaction to fire	Class A1
Resistance to fire	$N_{Rk,s,fi}$; $V_{Rk,s,y,fi}$ see Annex C13

3.3 Aspects of durability linked with the Basic Works Requirements

Essential characteristic	Performance
Durability	See Annex B1

Assessment and verification of constancy of performance (AVCP) system applied, with reference to its legal base

In accordance with EAD No. 330008-03-0601, the applicable European legal act is:
[2000/273/EC].

The system to be applied is: 1

5 Technical details necessary for the implementation of the AVCP system, as provided for in the applicable EAD

Technical details necessary for the implementation of the AVCP system are laid down in the control plan deposited with Deutsches Institut für Bautechnik.

Issued in Berlin on 2 August 2024 by Deutsches Institut für Bautechnik

Beatrix Wittstock
Head of Section

beglaubigt:
Müller

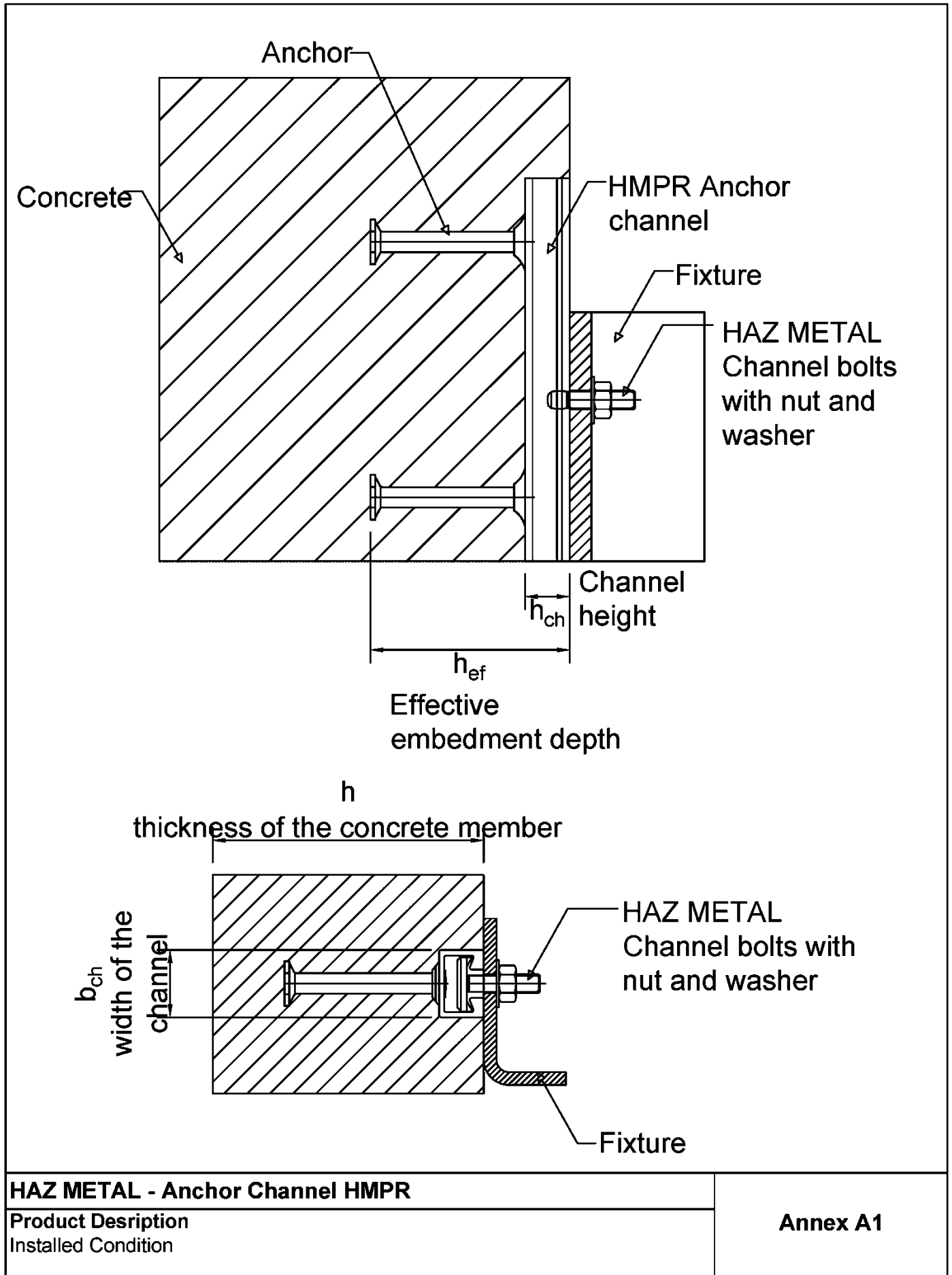

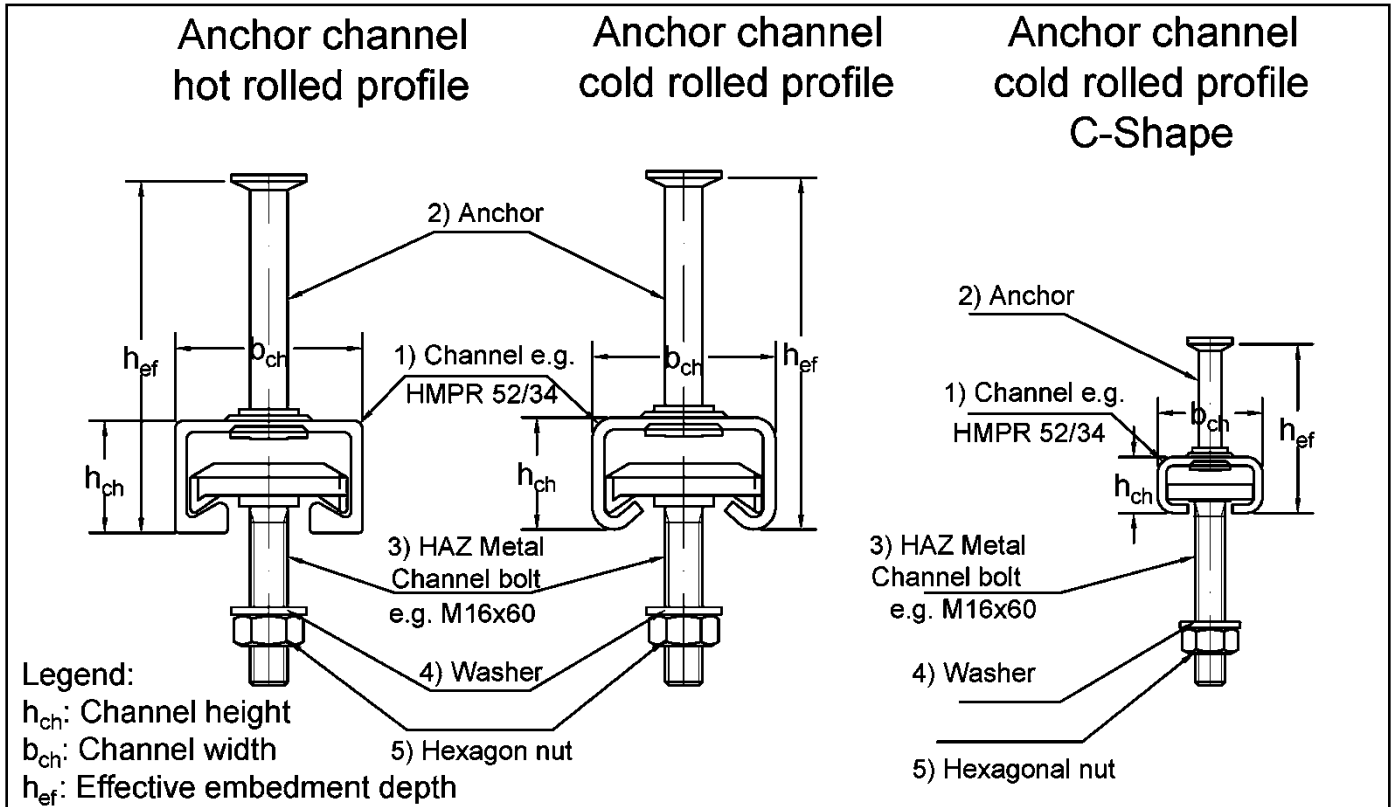

Marking of the HAZ - Anchor channel
e.g. HAZ 54/33 - A4

HAZ = Identifying mark of the manufacturer
54/33 = Size
A4 = Material

Marked on the back of the channel
or

Marked inside of the channel

Material of channels:
No marking for
1.0038 / 1.0044

A4=1.4401 / 1.4404 / 1.4571
A2=1.4301
L4=1.4362
HC=1.4529 / 1.4547
F4=1.4462

Marking of the HAZ - Channel bolt
e.g. HSK A4-70

HS/HAZ = Identifying mark of the manufacturer
K = notching bolt
A4 - 70 = Material / Strength grade

Material / Strength grade channel bolts:
Steel
8.8 = Strength grade 8.8

EP = Electroplated
HDG = hot dip galvanized

Stainless Steel
A4-70 = Stainless steel (1.4401 / 1.4404 / 1.4571)
Grade - 70
L4-70 = Stainless steel (1.4362) Grade - 70
HC-70 = Stainless steel (1.4529 / 1.4547)
Grade - 70
F4-70 = Stainless steel (1.4462) Grade - 70

HAZ METAL - Anchor Channel HMPR

Product Description
Marking and Materials

Annex A2

1	2	3	4	5	6	7
Item No	Specification	Structures subject to dry internal conditions	Structures subject to internal conditions with usual humidity (e.g. kitchen, bath and laundry in residential buildings, exceptional permanently damp conditions and application under water)	For CRC III according to EN 1993-1-4: 2006+A1:2015	For CRC IV according to EN 1993-1-4: 2006+A1:2015	For CRC V according to EN1993-1-4: 2006+A1:2015
		Materials				
1	Channel Profile	Steel 1.0038/ 1.0044 EN 10025-2:2005 hot-dip galv. $\geq 50 \mu\text{m}^2$ Stainless steel 1.4301 EN 10088-2:2009	Steel 1.0038/ 1.0044 EN 10025-2: 2005 hot-dip galv. $\geq 50 \mu\text{m}^2$	Stainless steel 1.4401/1.4404/ 1.4571/ 1.4362 EN 10088-2:2009	Stainless steel 1.4462 EN 10088-2:2009	Stainless steel EN 10088-2:2009 1.4529 / 1.4547 EN 10088-2:2009
2	Anchor	Steel 1.0038/ 1.0214/ 1.0401, 1.1132/ 1.5525 EN10263-2:2017 hot-dip galv. $\geq 50 \mu\text{m}^2$ Stainless steel 1.4301 EN 10088-2:2009	Steel 1.0038/ 1.0214/ 1.0401/ 1.1132/ 1.5525 EN 10263-2: 2017 hot-dip galv. $\geq 50 \mu\text{m}^2$	Stainless steel 1.4401/ 1.4404/ 1.4571/ 1.4578/ 1.4362 EN 10088-2:2009	Stainless steel 1.4462 EN 10088-2:2009	Stainless steel 1.4529 / 1.4547 EN 10088-2:2009
3	HAZ METAL Channel bolt thread and shaft EN ISO 4018:2022	Steel, strength grade 8.8 EN ISO 898-1: 2013 electroplated $\geq 5 \mu\text{m}^1$	Steel, strength grade 8.8 EN ISO 898-1: 2013 hot-dip galv. $\geq 50 \mu\text{m}^2$	Stainless steel 1.4401/ 1.4404/ 1.4571/ 1.4362 EN ISO 3506-1:2009	Stainless steel 1.4462 EN ISO 3506-1: 2009	Stainless steel 1.4529 / 1.4547 EN ISO 3506-1: 2009
4	Washer, EN ISO 7089:2000, EN ISO 7093-1:2000 production class A, 200HV	Steel EN10025-2: 2005 electroplated $\geq 5 \mu\text{m}^1$	Steel EN10025-2: 2005 hot-dip galv. $\geq 50 \mu\text{m}^2$	Stainless steel 1.4401/ 1.4404/ 1.4571 EN10088-2: 2009	Stainless steel 1.4462 EN 10088-2: 2009	Stainless steel 1.4529 / 1.4547 EN 10088-2: 2009
5	Hexagonal nuts EN ISO 4032:2012	Steel, strength grade 8 EN ISO 898-2: 2013 electroplated $\geq 5 \mu\text{m}^2$	Steel, strength grade 8 EN ISO 898-2:2013 hot-dip galv. $\geq 50 \mu\text{m}^2$	Stainless steel 1.4401/ 1.4404/ 1.4571 EN ISO 3506-2:2009	Stainless steel 1.4462 EN ISO 3506-2: 2009	Stainless steel 1.4529 / 1.4547 EN ISO 3506-2: 2009

1) Electroplated acc. EN ISO 4042:2022

2) Hot-dip galvanized on the basis of EN ISO 1461:2009, but coating thickness $\geq 50 \mu\text{m}$

HAZ METAL - Anchor Channel HMPR

Product Description
Materials and intended use

Annex A3

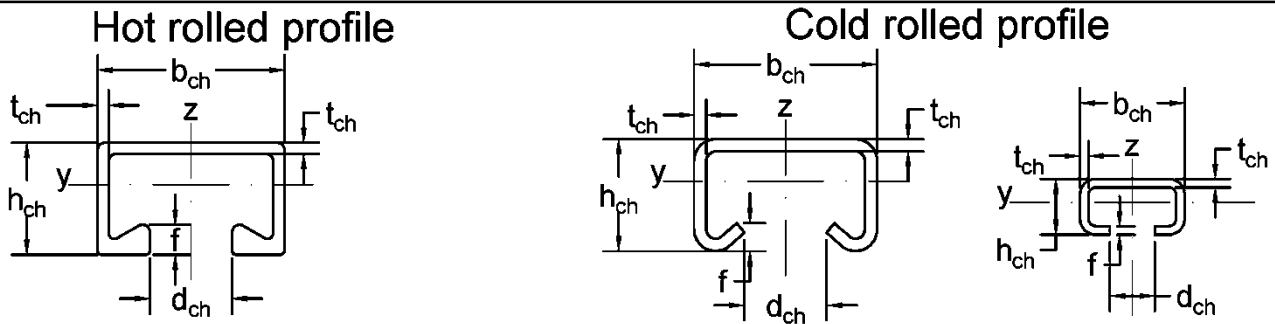

Table 2: Dimensions of profiles

Anchor channel	Fig.	Material	Dimensions					
			b _{ch}	h _{ch}	t _{ch}	d _{ch}	f	I _y
			[mm]					
28/15	3	Steel	28,00	15,00	2,30	12,00	2,30	3.727
38/17	3		38,00	17,00	3,00	18,00	3,00	7.629
40/25 40/26P	2		40,00	25,00	2,75	18,00	6,00	19.448
49/30	2		49,00	30,00	3,25	22,00	7,50	41.119
54/33	2		54,00	33,00	5,00	22,00	7,50	72.572
72/49	2		72,00	49,00	6,00	33,00	9,00	312.071
40/22	1		40,00	22,00	2,50	18,00	6,00	18.970
40/22P	1		40,00	22,00	3,00	18,00	6,00	20.030
50/30 50/30P	1		50,00	30,00	3,00	22,00	8,00	57.630
52/34 52/34P	1		52,00	34,00	4,00	22,00	10,00	97.150
28/15	3		Stainless steel	28,00	15,00	2,30	12,00	2,30
38/17	3	38,00		17,00	3,00	18,00	3,00	7.629
40/25 40/26P	2	40,00		25,00	2,75	18,00	6,00	19.448
49/30	2	49,00		30,00	3,25	22,00	7,50	41.119
54/33	2	54,00		33,00	5,00	22,00	7,50	72.572
72/49	2	72,00		49,00	6,00	33,00	9,00	312.071

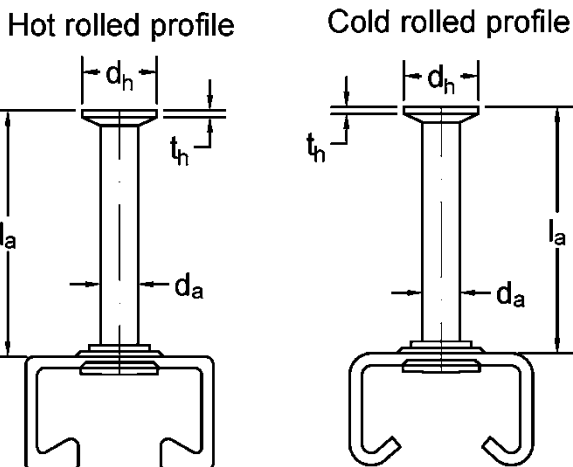

Table 3: Dimensions of round anchors

Anchor channel	Dimensions				
	d _a	d _h	t _h	l _a	A _h
	[mm]				
28/15	6	12	1,8	32	84,82
38/17	8	16	1,8	61	150,80
40/25 40/22	8	16	1,8	56	150,80
40/22P 40/26P	10	20	1,8	71	235,62
49/30 50/30	10	20	1,8	66	235,62
50/30P	12	24	2,0	78	339,29
54/33 52/34	12	24	2,0	124	339,92
52/34P	14	28	2,5	124	461,81
72/49	16	32	3,0	133	603,19

HAZ METAL - Anchor Channel HMPR

Product Description
Dimensions of profiles / Dimension of anchors

Annex A4

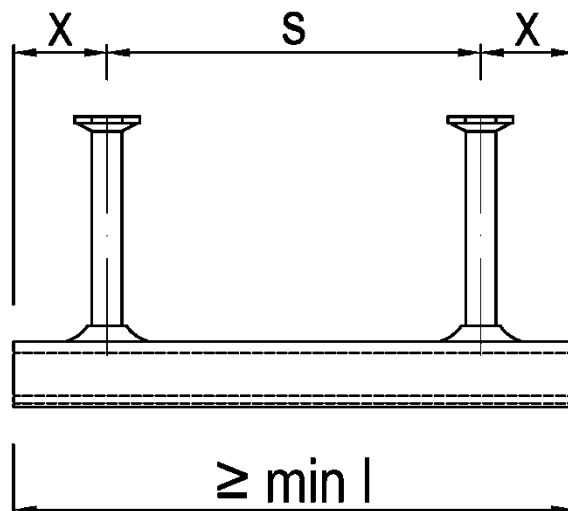

Table 4: Anchor Positioning

Anchor channel	Anchor spacing		End spacing	Min. channel length
	s_{min}	s_{max}	x	min l
	[mm]			
28/15 38/17	50	200	25	100
40/25 40/22 40/22P 40/26P 49/30	100	250	25	150
50/30 50/30P 54/33 52/34 52/34P	100	250	35	170
72/49	130	400	35	200

HAZ METAL - Anchor Channel HMPR

Product Description

Anchor positioning, channel length

Annex A5

Hammer-head channel bolt

Fig. 1

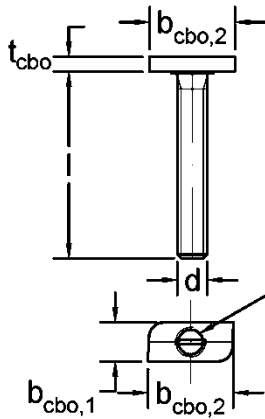

Hook-head channel bolt

Fig. 2

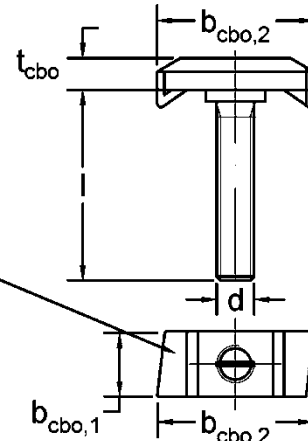

Marking of the channel bolt
acc. to Annex A2

Groove for marking the position

Table 5: Dimension of the HAZ METAL channel bolt - Type HS

HS Channel Bolt	Anchor Channel	Material	d	b _{cbo,1}	b _{cbo,2}	t _{cbo}	Fig.	Length l
			[mm]	[mm]	[mm]	[mm]		
28/15	28/15	A4-70 8.8	8	10	23	4	1	15-200
			10	10	23	5	1	20-300
			12	10	23	5	1	20-300
38/17	38/17		10	13	31	6	1	20-300
			12	13	31	7	1	20-300
			16	16	31	7	1	20-300
40/22	40/25 40/22 40/22P 40/26P		10	14	35	7,5	2	20-300
			12	14	35	7,5	2	20-300
			16	14	34	8,5	2	30-300
50/30	49/30 50/30 50/30P 54/33 52/34 52/34P		12	13	43,2	10	2	20-300
			16	17	43,2	11	2	20-300
			20	21	42,2	12	2	30-300
72/49	72/49		20	23	58	14	2	50-300
			24	25	58	16	2	50-300
			30	31	58	20	2	50-300

Table 6: Dimension of the HAZ METAL channel bolt - Type HAZ

HAZ Channel Bolt	Anchor Channel	Material	d	b _{cbo,1}	b _{cbo,2}	t _{cbo}	Fig.	Length l
			[mm]	[mm]	[mm]	[mm]		
28/15	28/15	8.8	8	10,5	23	4	1	25-100
			10	10,5	23	5	1	30-100
			12	12	23	5	1	50-100
38/17	38/17		10	13	31	7	1	40-100
			12	13	31	7	1	40-100
			16	17	31	7	1	60-150
40/22	40/25 40/22 40/22P 40/26P		10	14	34	8,5	2	30-100
			12	14	34	8,5	2	50-100
			16	17	34	8,5	2	60-100
50/30	49/30 50/30 50/30P 54/33 52/34 52/34P		12	17,5	42	8,5	2	50-100
			16	17	42	8,5	2	50-125

HAZ METAL - Anchor Channel HMPR

Product Description
Type HS and HAZ Channel bolts, Dimensions

Annex A6

HAZ notching channel bolt Type HSK

Fig. 3

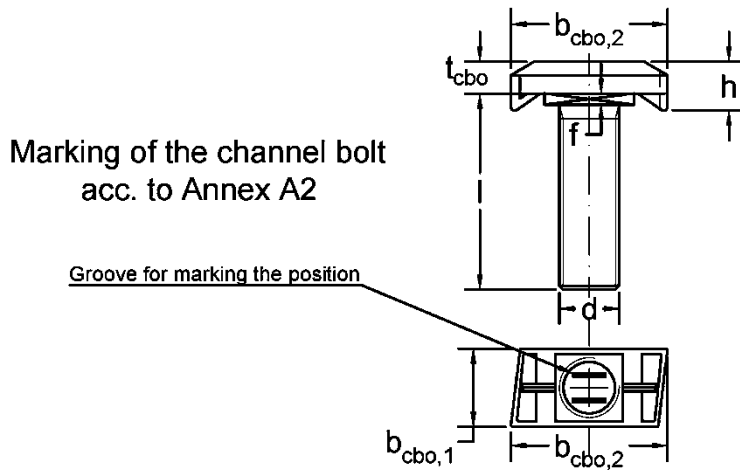

Table 7: Dimension of the HAZ METAL channel bolt - Type HSK

HAZ Notching Channel Bolt	Anchor Channel	Material	d	b _{cbo,1}	b _{cbo,2}	t _{cbo}	h	f	Length l
			[mm]	[mm]	[mm]	[mm]	[mm]	[mm]	[mm]
40/22	40/22P	8.8	16	14	34	8,5	11,5	3	30-300
50/30	50/30P		16	17	43,2	11	14,5	4	20-300
	52/34P		20	21	42,2	12	15,5	4	30-300

Table 8: Strength grade of channel bolts

Channel Bolt	HS, HAZ and HSK	HS
	Steel	Stainless Steel
Strength grade	8.8	70
f _{uk} [N/mm ²]	800	700
f _{ukI} [N/mm ²]	640	450
Finish	electroplated, hot-dip galvanized	-

HAZ METAL - Anchor Channel HMPR

Product Description

HSK Channel bolts: Dimensions,
HS, HAZ and HSK: Strength grade

Annex A7

Specifications of intended use

Anchor channel and channel bolts subject to:

- Static and quasi-static tension, shear perpendicular to the longitudinal axis of the channel
- Static and quasi-static shear in the direction of the longitudinal axis of the channel (anchor channels 40/22P, 50/30P, 53/34P with notching bolts Type HSK)
- Fatigue cyclic tension loading (anchor channels with channel bolts for assesment methode A1, A2 and B according to Annex C10)
- Fire exposure for concrete class C20/25 to C50/C60 for tension and shear perpendicular to the longitudinal axis of the channel (anchor channels and channel bolts according to Annex C13)

Base materials:

- Reinforced or unreinforced normal weight concrete according to EN 206-1:2000
- Strength classes C20/25 to C90/105 according to EN 206-1:2000
- Cracked or uncracked concrete

Use conditions (Environmental conditions):

- Structures subject to dry internal conditions (anchor channels and channel bolts according to Annex A3, Table 1, column 3-7)
- Structures subject to internal conditions with usual humidity (e.g. kitchen, bath and laundry in residential buildings, except permanently damp conditions and application under water) (anchor channels and channel bolts accordingly to Annex A3, Table 1, column 4-7)
- According to EN 1993-1-4:2006+A2:2015 relating to corrosion resistance class CRC III (anchor channels and channel bolts according to Annex A3, Table 1, column 5-7)
- According to EN 1993-1-4:2006+A2:2015 relating to corrosion resistance class CRC IV (anchor channels and channel bolts according to Annex A3, Table 1, column 6-7)
- According to EN 1993-1-4:2006+A2:2015 relating to corrosion resistance class CRC V (anchor channels and channel bolts according to Annex A3, Table 1, column 7)

Design:

- Anchor channel are designed under the responsibility of an engineer experienced in anchorages and concrete work.
- Verifiable calculation notes and drawings are prepared taking account of the loads to be anchored. The position of the anchor channel and channel bolts are indicated on the design drawings (e.g. position of the anchor channel relative to the reinforcement or to the supports)
- For static and quasi-static loading as well as fire exposure the anchor channels are designed in accordance with EN 1992-4:2018, EOTA TR 047 "Design of Anchor Channels", May 2021.
- For fatigue loading the anchor channels are designed in accordance with EOTA TR 050 "Calculation Method for the Performance of Anchor channels under Fatigue Loading", June 2022.
- The characteristic resistances are calculated with the minimum effective embedment depth.

HAZ METAL - Anchor Channel HMPR

Intended use
Specifications

Annex B1

Installation:

- The installation of anchor channels is carried out by appropriately qualified personnel under the supervision of the person responsible for the technical matters on site.
- Use of the anchor channels only as supplied by the manufacturer -without any manipulations, repositioning or exchanging of the channel components.
- Cutting of anchor channels is allowed only if pieces according Annex A5, Table 4 are generated including end spacing and minimum channel length and only to be used in dry internal conditions. (Annex A3, Table A1, column 3-4). For anchor channels made of stainless steel there are no restrictions regarding corrosion resistance when using cut channel pieces, if cutting is done professionally and contamination of cut edges with corrosion material is avoided.
- Installation in accordance with the manufacturer's specifications given in Annexes B7 to B9.
- The anchor channels are fixed on the formwork, reinforcement such that no movement of the channels will occur during the time of laying the reinforcement or auxiliary construction of placing and compacting the concrete.
- The concrete under the head of the anchors is properly compacted. The channels are protected from penetration of concrete into the internal space of the channels.
- Washer may be chosen according to Annex A3 and provided separately by the user.
- Orientating the channel bolts (groove according to Annex A6 and A7) rectangular to the channel axis.
- The installation torques given in Annex B4 and B5 shall be applied and shall not be exceeded.

HAZ METAL - Anchor Channel HMPR

**Intended use
Specifications**

Annex B2

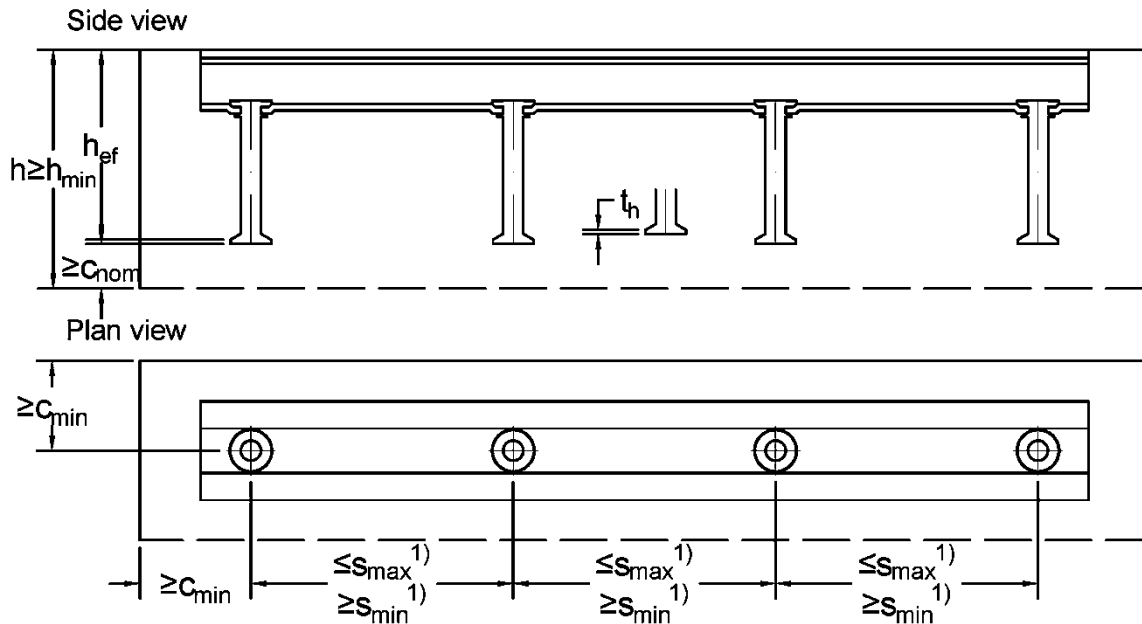

Table 9: Minimum effective embedment depth, edge distance and member thickness for cold rolled and hot rolled profiles

Anchor channel		Min. effective embedment depth	Min. edge distance	Min. member thickness
		min h_{ef}	c_{min}	$h_{min}^{2)}$
[mm]				
Cold rolled profile	28/15	45	40	77
	38/17	76	50	108
	40/25	79	50	111
	40/26P	94	50	120
	49/30	94	75	126
	54/33	155	100	187
Hot rolled profile	72/49	179	150	215
	40/22	76	50	108
	40/22P	91	50	123
	50/30	94	75	126
	50/30P	106	75	138
	52/34	156	100	188
	52/34P	156	100	188

1) s_{min} ; s_{max} acc. to Annex A5, Table 4

2) $h_{min} \geq h_{ef} + t_h + c_{nom}$; c_{nom} acc. to EN 1992-1-1:2004 + A1:2014, t_h acc. to Annex A4, Table 3

HAZ METAL - Anchor Channel HMPR

Intended use
Installation parameters of anchor channels

Annex B3

Table 10: Minimum spacing and installation torques of HAZ METAL -
Channel bolts Type HS

Channel bolt for cold profiles	Channel bolt d	Min. spacing $s_{\min, cbo}^{3)}$ of the channel bolts	Installation torque $T_{\text{Inst.}}^{4)}$		
			General $T_{\text{Inst.}, g}^{1)}$	Steel-steel contact $T_{\text{Inst.}, s}^{2)}$	
			8.8; 70	8.8	70
[mm]		[Nm]			
28/15	8	40	8	20	20
	10	50	13	40	40
	12	60	15	40	40
38/17	10	50	15	40	40
	12	60	25	70	70
	16	80	40	120	120
40/25 40/26P	10	50	15	40	40
	12	60	25	70	50
	16	80	40	150	140
49/30	12	60	25	70	50
	16	80	60	180	160
	20	100	75	90	150
54/33	12	60	25	70	50
	16	80	60	180	180
	20	100	120	120	240
72/49	20	100	120	360	130
	24	120	200	360	230
	30	150	380	400	- ⁵⁾
Channel bolt for hot profiles	Channel bolt d	Min. spacing $s_{\min, cbo}^{3)}$ of the channel bolts	Installation torque $T_{\text{Inst.}}^{4)}$		
			General $T_{\text{Inst.}, g}^{1)}$	Steel-steel contact $T_{\text{Inst.}, s}^{2)}$	
			8.8; 70	8.8	
[mm]		[Nm]			
40/22 40/22P	10	50	15	40	
	12	60	25	70	
	16	80	45	100	
50/30 50/30P	12	60	25	70	
	16	80	60	180	
	20	100	75	120	
52/34 52/34P	12	60	25	70	
	16	80	60	180	
	20	100	120	150	

- 1) Acc. to Annex B7, Fig 1
- 2) Acc. to Annex B7, Fig 2
- 3) See Annex C1, Fig 1
- 4) T_{Inst} shall not be exceeded
- 5) Product not available

HAZ METAL - Anchor Channel HMPR

Intended use
Installation parameters of HAZ METAL - Channel bolts Type HS

Annex B4

Table 11: Minimum spacing and installation torques of HAZ METAL -
Channel bolts Type HAZ

Channel bolt for cold profiles	Channel bolt d	Min. spacing $s_{\min, \text{cbo}}^{3)}$ of the channel bolts	Installation torque $T_{\text{Inst.}}^{4)}$	
			General ¹⁾ $T_{\text{Inst.},g}$	Steel-steel contact ²⁾ $T_{\text{Inst.},s}$
			8.8; 70	8.8
[mm]			[Nm]	
28/15	8	40	8	15
	10	50	13	20
	12	60	15	20
38/17	10	50	15	30
	12	60	25	40
	16	80	45	50
40/25 40/26P	10	50	15	40
	12	60	25	50
	16	80	45	70
49/30	12	60	25	70
	16	80	60	120
54/33	12	60	25	70
	16	80	60	180
Channel bolt for hot profiles	Channel bolt d	Min. spacing $s_{\min, \text{cbo}}^{3)}$ of the channel bolts	Installation torque $T_{\text{Inst.}}^{4)}$	
			General ¹⁾ $T_{\text{Inst.},g}$	Steel-steel contact ²⁾ $T_{\text{Inst.},s}$
			8.8; 70	8.8
[mm]			[Nm]	
40/22 40/22P	10	50	15	30
	12	60	25	40
	16	80	45	60
50/30 50/30P	12	60	25	60
	16	80	60	120
52/34 52/34P	12	60	25	70
	16	80	60	180

- 1) Acc. to Annex B7, Fig 1
- 2) Acc. to Annex B7, Fig 2
- 3) See Annex C1, Fig 1
- 4) $T_{\text{Inst.}}$ shall not be exceeded

HAZ METAL - Anchor Channel HMPR

Intended use
Installation parameters of HAZ METAL - Channel bolts Type HAZ

Annex B5

Table 12: Minimum spacing and installation torques of HAZ METAL -
Notching channel bolts Type HSK

Channel bolt for hot profiles	Notching channel bolt d	Min. spacing $s_{\min, \text{cbo}}$ ³⁾ of the channel bolts	Installation torque $T_{\text{Inst.}}$ ⁴⁾	
			General ¹⁾ $T_{\text{Inst,g}}$	Steel-steel contact ²⁾ $T_{\text{Inst,s}}$
			8.8	8.8
		[mm]	[Nm]	
40/22P	16	80	250	250
50/30P	16	80	250	250
52/34P	20	100	420	420

- 1) Acc. to Annex B7, Fig 1
- 2) Acc. to Annex B7, Fig 2
- 3) See Annex C1, Fig 1
- 4) T_{Inst} shall not be exceeded

HAZ METAL - Anchor Channel HMPR

Intended use
Installation parameters of HAZ METAL - Notching channel bolts Type HSK

Annex B6

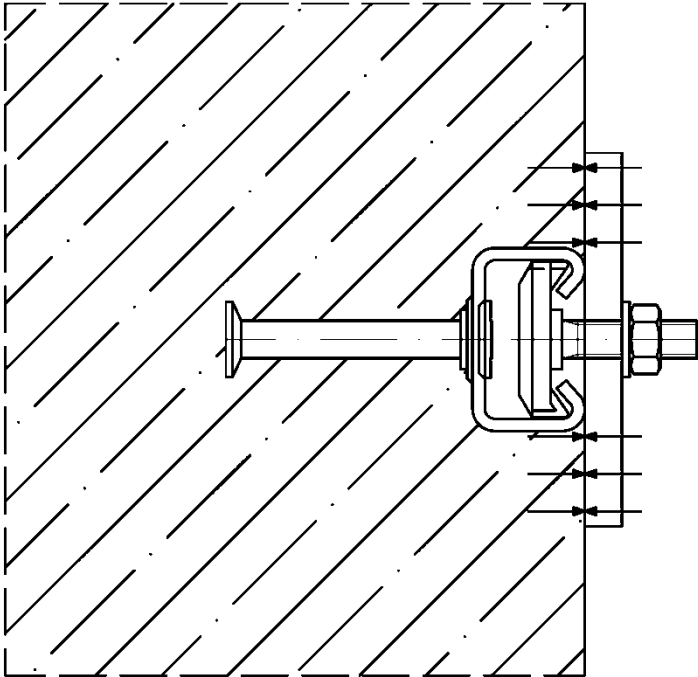

Fig. 1

General:

The fixture is in contact with the channel profile and the concrete surface.

The installation torques according to Annex B4, Table 10, Annex B5, Table 11 and Annex B6, Table 12 shall be applied and shall not be exceeded.

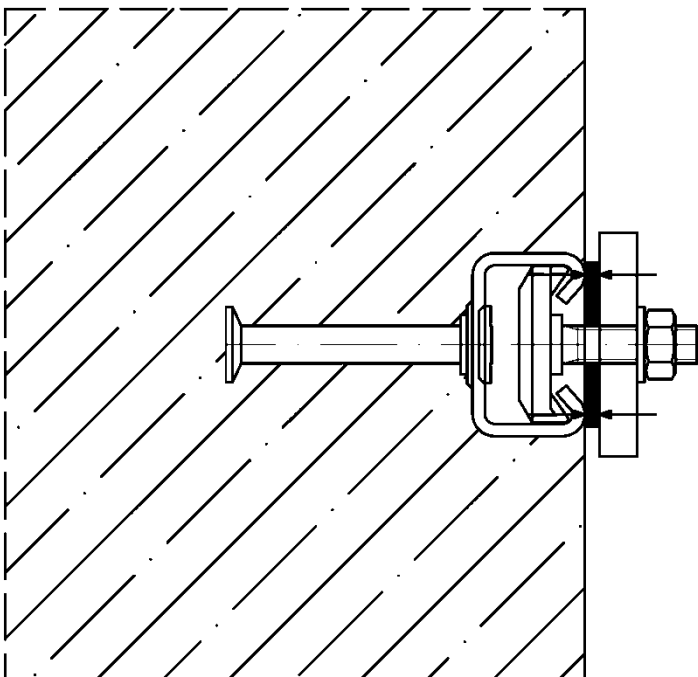

Fig. 2

Steel - Steel Contact:

The fixture is not in contact with the concrete surface. The fixture is fastened to the anchor channel by suitable steel part (e.g. washer).

The installation torques according to Annex B4, Table 10, Annex B5, Table 11 and Annex B6, Table 12 shall be applied and shall not be exceeded.

HAZ METAL - Anchor Channel HMPR

Intended use
Positions of the fixture

Annex B7

1. Fixing anchor channel

Install the channel surface flush and fix the channel undisplaceable to the formwork or to the reinforcement

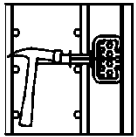
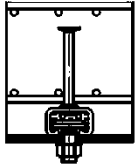

a) Fixing to steel formwork

With HAZ METAL channel bolts and nuts, with rivets cramps or with magnetizing fixings.

or

b) Fixing to timber formwork

With nails through the pre-punched holes in the back of the channels and with staples.

or

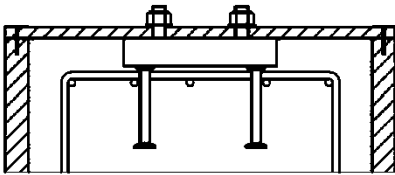

c) Fixing of anchor channels at the top

- To timber batten on the side formwork (e.g. with HAZ METAL channel bolts)
- Fixing from above directly to the reinforcement or to a mounting rebar, attach the channel by wire binding.

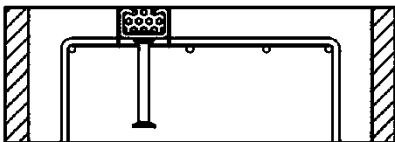

2. Pouring concrete and regular compacting of concrete

Compact the concrete properly around the channel and the anchors.

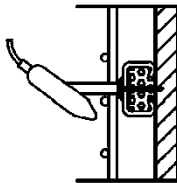

a) Sidefaces to the formwork

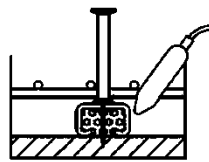

b) in soffits

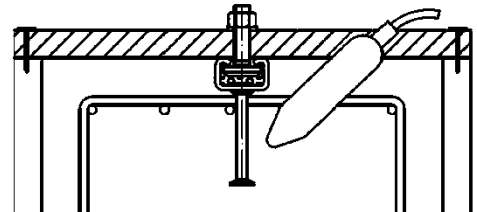

c) into top surfaces of concrete up stands

3. Removing of the channel infill

Clean the channel on the outside after removing the formwork

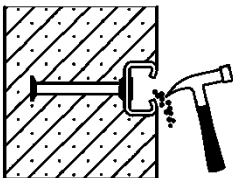

a) Foam infill

With a hammer or a hook or

b) PE - foam infill

By hand or with help of a screw driver in one piece

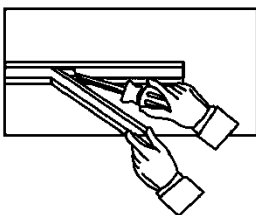

HAZ METAL - Anchor Channel HMPR

Intended use

Installation instructions for HAZ METAL anchor channels

Annex B8

4. Fastening the HAZ METAL channel bolt to the anchor channel

Fig. 1

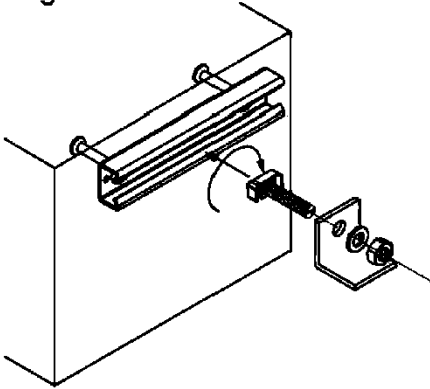
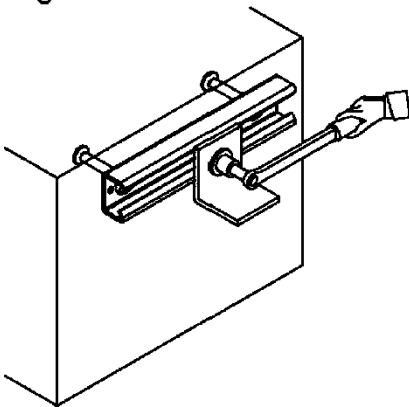

Fig. 2



a) Setting torques (General)

1. Insert the HAZ METAL channel bolt into the channel slot at any point along the channel length (Fig.1)
2. Turn the channel bolt 90° clockwise and the head of the screw locks into position (Fig.1)
3. Do not mount the channel bolt close than 25 mm resp. 35 mm (HMPR 54/33) from the end of the channel.
4. Use the washer under nut (Fig.1)
5. Check the correct fit of the screw. The groove on the shank end of the channel bolt must be perpendicular to the longitudinal axis.
6. Tighten the nuts to the installation torque according to Table 13, 14 and 15 (Fig.2). The installation torque must not be exceeded.

Table 13: Installation torques (General) for HAZ METAL channel bolts Type HS

	Anchor channel	T _{Inst,g} [Nm]						
		M8	M10	M12	M16	M20	M24	M30
8.8 70	28/15	8	13	15	- ¹⁾	- ¹⁾	- ¹⁾	- ¹⁾
	38/17	- ¹⁾	15	25	40	- ¹⁾	- ¹⁾	- ¹⁾
	40/25 40/26P	- ¹⁾	15	25	40	- ¹⁾	- ¹⁾	- ¹⁾
	49/30	- ¹⁾	- ¹⁾	25	60	75	- ¹⁾	- ¹⁾
	54/33	- ¹⁾	- ¹⁾	25	60	120	- ¹⁾	- ¹⁾
	72/49	- ¹⁾	- ¹⁾	- ¹⁾	- ¹⁾	120	200	380
	40/22 40/22P	- ¹⁾	15	25	45	- ¹⁾	- ¹⁾	- ¹⁾
	50/30 50/30P	- ¹⁾	- ¹⁾	25	60	75	- ¹⁾	- ¹⁾
52/34 52/34P	- ¹⁾	- ¹⁾	25	60	120	- ¹⁾	- ¹⁾	

1) Product not available

Table 14: Installation torques (General) for HAZ METAL channel bolts Type HAZ

	Anchor channel	T _{Inst,g} [Nm]			
		M8	M10	M12	M16
8.8	28/15	8	13	15	- ¹⁾
	38/17 40/25 40/26P 40/22 40/22P	- ¹⁾	15	25	45
	49/30 54/33 50/30 50/30P 52/34 52/34P	- ¹⁾	- ¹⁾	25	60

1) Product not available

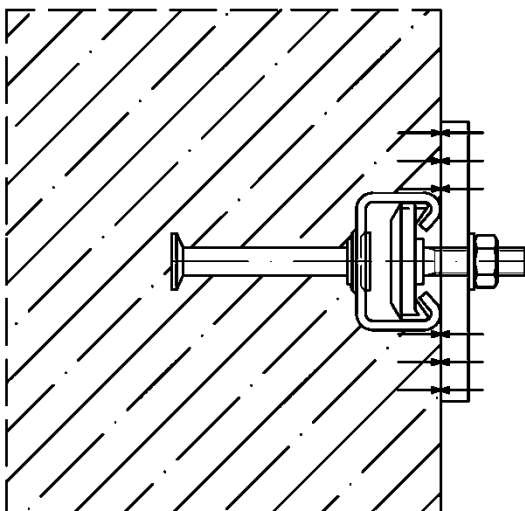

Table 15: Installation torques (General) for HAZ METAL notching channel bolts Type HSK

	Anchor channel	T _{Inst,g} [Nm]	
		M16	M20
8.8	40/22P	250	- ¹⁾
	50/30P	250	- ¹⁾
	52/34P	- ¹⁾	420

1) Product not available

HAZ METAL - Anchor Channel HMPR

Intended use
Installation instructions for HAZ METAL anchor channels (General)

Annex B9

Fig. 1

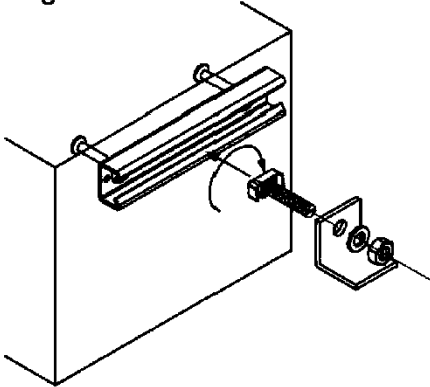
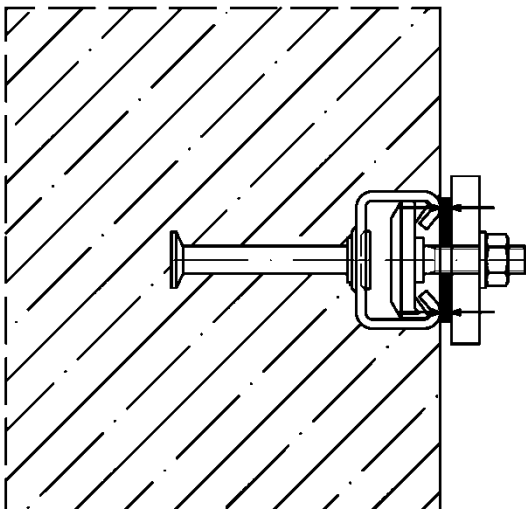
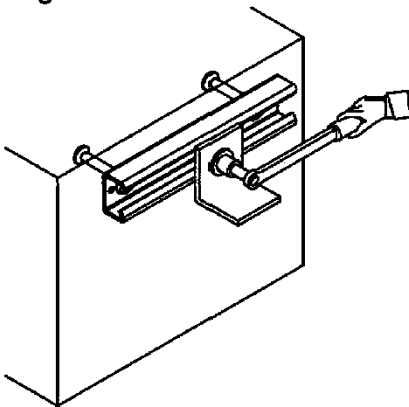

Fig. 2



b) Installation torques (Steel-Steel Contact)

1. Use washers between the channel and the fixture to create a defined contact.
2. Tighten the nuts to the installation torque according to Table 16, 17 and 18

Table 16: Installation torques (Steel-Steel contact) for HAZ METAL channel bolts Type HS

	Anchor channel	T _{Inst,s} [Nm]						
		M8	M10	M12	M16	M20	M24	M30
8.8	28/15	8	13	15	- ¹⁾	- ¹⁾	- ¹⁾	- ¹⁾
	38/17	- ¹⁾	15	25	40	- ¹⁾	- ¹⁾	- ¹⁾
	40/25 40/26P	- ¹⁾	15	25	40	- ¹⁾	- ¹⁾	- ¹⁾
	49/30	- ¹⁾	- ¹⁾	25	60	75	- ¹⁾	- ¹⁾
	54/33	- ¹⁾	- ¹⁾	25	60	120	- ¹⁾	- ¹⁾
	72/49	- ¹⁾	- ¹⁾	- ¹⁾	- ¹⁾	120	200	380
	40/22 40/22P	- ¹⁾	15	25	45	- ¹⁾	- ¹⁾	- ¹⁾
	50/30 50/30P	- ¹⁾	- ¹⁾	25	60	75	- ¹⁾	- ¹⁾
70	52/34 52/34P	- ¹⁾	- ¹⁾	25	60	120	- ¹⁾	- ¹⁾
	28/15	20	40	40	- ¹⁾	- ¹⁾	- ¹⁾	
	38/17	- ¹⁾	40	70	120	- ¹⁾	- ¹⁾	
	40/25 40/26P	- ¹⁾	40	50	140	- ¹⁾	- ¹⁾	
	49/30	- ¹⁾	- ¹⁾	50	160	150	- ¹⁾	
	54/33	- ¹⁾	- ¹⁾	50	180	240	- ¹⁾	
	72/49	- ¹⁾	- ¹⁾	- ¹⁾	- ¹⁾	130	230	

1) Product not available

Table 17: Installation torques (Steel-Steel contact) for HAZ METAL channel bolts Type HAZ

	Anchor channel	T _{Inst,s} [Nm]			
		M8	M10	M12	M16
8.8	28/15	15	20	20	- ¹⁾
	38/17	- ¹⁾	30	40	50
	40/25 40/26P	- ¹⁾	40	50	70
	49/30	- ¹⁾	- ¹⁾	70	120
	54/33	- ¹⁾	- ¹⁾	70	120
	40/22 40/22P	- ¹⁾	30	40	60
	50/30 50/30P	- ¹⁾	- ¹⁾	60	120
	52/34 52/34P	- ¹⁾	- ¹⁾	70	180

1) Product not available

Table 18: Installation torques (Steel-Steel contact) for HAZ METAL notching channel bolts Type HSK

	Anchor channel	T _{Inst,s} [Nm]	
		M16	M20
8.8	40/22P	250	- ¹⁾
	50/30P	250	- ¹⁾
	52/34P	- ¹⁾	420

1) Product not available

HAZ METAL - Anchor Channel HMPR

Intended use

Installation instructions for HAZ METAL anchor channels (Steel-Steel contact)

Annex B10

Table 19: Characteristic resistances under tension load - Steel failure of anchor channel

Anchor Channel			28/15	38/17	40/25	40/26P	49/30	54/33	72/49	40/22	50/30	52/34	40/22P	50/30P	52/34P
Steel failure: Anchor	$N_{Rk,s,a}$ [kN]	Steel	14	25	25	39,3	39	90	100	25	39	56	39,3	56,5	77
		Stainless Steel	17	30	30	47,1	47	68	130	_)	_)	_)	_)	_)	_)
	γ_{Ms} ¹⁾	Steel	1,80												
		Stainless Steel	1,80												
Steel failure: Connection between Anchor and Channel	$N_{Rk,s,c}$ [kN]	Steel	13	19	22	24,2	31	75	81	22,7	31,8	53,6	28,6	40,2	51,6
		Stainless Steel	15	22	27	26,6	45	66	91	_)	_)	_)	_)	_)	_)
	$\gamma_{Ms,ca}$ ¹⁾	Steel	1,80												
		Stainless Steel	1,80												
Steel failure: Local flexure of channel lips	$s_{I,N}$ [mm]	Steel	56	76	80	80	98	108	144	80	100	104	80	100	104
		Stainless Steel	56	76	80	80	98	108	144	_)	_)	_)	_)	_)	_)
	$N^0_{Rk,s,l}$ [kN]	Steel	13	19	22	22,8	31	75	81	22,7	32,7	53,6	30,3	50,1	70,1
		Stainless Steel	15	22	27	30,9	45	66	91	_)	_)	_)	_)	_)	_)
	$\gamma_{Ms,l}$ ¹⁾	Steel	1,80												
		Stainless Steel	1,80												

- 1) In absence of other regulations
2) No performance assessed

Table 20: Characteristic flexural resistance under tension load

Anchor Channel				28/15	38/17	40/25	40/26P	49/30	54/33	72/49	40/22	50/30	52/34	40/22P	50/30P	52/34P
Characteristic flexural resistance of channel	$M_{Rk,s,flex}$ [Nm]	Type HS and HAZ	Steel	349	595	1356	1356	1893	3257	11349	1450	3110	2806	1450	3110	2806
			Stainless Steel	348	651	1048	1048	1840	3101	7370	_)	_)	_)	_)	_)	_)
		Type HSK	Steel	_)	_)	_)	_)	_)	_)	_)	_)	_)	_)	_)	725	1595
Partial factor	$\gamma_{Ms,flex}$ ¹⁾	Type HS, HAZ and HSK	Steel	1,15												
			Stainless Steel	1,15												

- 1) In absence of other regulations
2) No performance assessed

HAZ METAL - Anchor Channel HMPR

Performances

Characteristic resistances under tension load -
Steel failure anchor channel

Annex C1

Table 21: Characteristic resistances under tension load -
Steel failure of channel bolts

Steel failure: Channel Bolts		28/15	38/17	40/22	50/30	72/49		
Characteristic resistance	$N_{Rk,s}$ [kN]	Type HS	M8 8.8	28,8	_2)	_2)	_2)	
			M10 8.8	36,5	41,9	46,4	_2)	_2)
			M12 8.8	43,2	31,2	61,9	63,2	_2)
			M16 8.8	_2)	42,5	111,7	108,1	_2)
			M20 8.8	_2)	_2)	_2)	165,7	117,1
			M24 8.8	_2)	_2)	_2)	_2)	214,9
			M30 8.8	_2)	_2)	_2)	_2)	324,1
				28/15	38/17	40/22	50/30	72/49
			M8 70	25,6	_2)	_2)	_2)	_2)
			M10 70	30,0	15,2	36,9	_2)	_2)
			M12 70	49,7	52,3	44,8	43,5	_2)
			M16 70	_2)	52,0	79,5	93,4	_2)
		M20 70	_2)	_2)	_2)	120,3	128,9	
		M24 70	_2)	_2)	_2)	_2)	171,2	
			28/15	38/17	40/22	50/30	72/49	
		Type HAZ	M8 8.8	27,9	_2)	_2)	_2)	_2)
			M10 8.8	39,2	44,4	43,2	_2)	_2)
			M12 8.8	43,9	63,9	65,6	64,0	_2)
			M16 8.8	_2)	86,6	92,6	95,3	_2)
		Type HSK				40/20	50/30	
			M16 8.8	_2)	_2)	111,7	108,1	_2)
			M20 8.8	_2)	_2)	_2)	165,7	_2)
		Partial factor	γ_{Ms} 1)	8.8	1,50			
				70	1,87			

- 1) In absence of other regulations
2) No performance assessed

HAZ METAL - Anchor Channel HMPR

Performances

Characteristic resistances under tension load -
Steel failure channel bolts

Annex C2

Table 22: Characteristic resistances under tension load -
Concrete failure of anchor channel

Anchor channel		28/15	38/17	40/25 40/22	40/22P 40/26P	49/30 50/30	50/30P	54/33 52/34	52/34P	72/49	
Concrete Failure: Pullout											
Charac. resistance in cracked concrete C20/25		N _{Rk,p} [kN]	12,7	22,6	22,6	35,4	35,3	50,9	50,9	69,4	90,5
Charac. resistance in uncracked concrete C20/25			17,8	31,7	31,7	49,6	49,5	71,4	71,3	97,1	126,7
Increasing factor of N _{Rk,p} = N _{Rk,p} (C20/25) · Ψ _c	C25/30	Ψ _c [-]	1,25								
	C30/37		1,50								
	C35/45		1,75								
	C40/50		2,00								
	C45/55		2,25								
	C50/60		2,50								
	C55/67		2,75								
	≥ C60/75		3,00								
Partial factor		γ _{Mp} = γ _{Mc} ¹⁾	1,50								
Concrete failure: Concrete cone											
Product factor	Cracked concrete	k _{cr,N}	7,2	7,8	7,8	8,0 8,1	8,2	8,1	8,7	8,7	8,9
	Uncracked concrete	k _{ucr,N}	10,3	11,2	11,2	11,5	11,7	11,5	12,4	12,4	12,7
Partial factor		γ _{Mc} ¹⁾	1,50								
Concrete failure: Splitting											
Characteristic edge distance	c _{cr,sp} [mm]	135	228	237 228	273 282	282	318	465 468	468	537	
Characteristic spacing	s _{cr,sp} [mm]	270	456	474 456	546 564	564	636	930 936	936	1074	
Partial factor		γ _{Mc} ¹⁾	1,50								

1) In absence of other regulations

HAZ METAL - Anchor Channel HMPR

Performances

Characteristic resistances under tension load -
Concrete failure

Annex C3

Table 23: Characteristic resistances under shear load

Anchor Channel			28/15	38/17	40/25	40/26P	49/30	54/33	72/49	40/22	50/30	52/34	40/22P	50/30P	52/34P	
Steel failure	Failure of anchor, connection between anchor and channel or local flexure of channel lips	$V_{Rk,s,a,y}$ [kN]	Steel	13	19	22	39	31	75	81	25	35	56	44,9	56,5	77
			Stainless Steel	15	22	27	47	45	66	91	_)	_)	_)	_)	_)	_)
		$V_{Rk,s,c,y}$ [kN]	Steel	13	19	22	24	31	75	91	22,7	31,8	53,6	44,9	40,2	51,6
			Stainless Steel	15	22	27	27	45	66	91	_)	_)	_)	_)	_)	_)
		$V_{Rk,s,l,y}^0$ [kN]	Steel	13	19	22	23	31	75	81	22,7	32,7	53,6	44,9	50,1	70,1
			Stainless Steel	15	22	27	31	45	66	91	_)	_)	_)	_)	_)	_)
		γ_{Ms}^1 [-]		1,80												
$s_{i,v}$ [mm]		56	76	80	80	98	108	144	80	100	104	80	100	104		
Concrete failure	Pry-out failure	k_8^2 [-]	1,0	2,0	2,0	2,0	2,0	2,0	2,0	2,0	2,0	2,0	2,0	2,0	2,0	2,0
		γ_{Mc}^1 [-]	1,50													
	Concrete edge failure	$k_{cr,v}$ [-]	Steel	6,1	7,5	7,2	6,7	6,8	7,5	7,5	6,5	7,5	7,5	7,3	7,5	7,5
			Stainless Steel	5,1	6,4	5,4	7,5	6,8	7,0	7,5	_)	_)	_)	_)	_)	_)
		$k_{ucr,v}$ [-]	Steel	8,5	10,5	10,1	9,4	9,0	10,5	10,5	9,1	10,5	10,5	10,2	10,5	10,5
			Stainless Steel	7,1	9,0	7,6	10,5	8,8	9,8	10,5	_)	_)	_)	_)	_)	_)
γ_{Mc}^1 [-]		1,50														

- 1) In absence of other regulations
- 2) In case of supplementary reinforcement, the factor k_8 should multiplied with 0,75
- 3) No performance assessed

HAZ METAL - Anchor Channel HMPR

Performances

Characteristic resistances under shear load -
Steel failure of anchor channel and concrete failure

Annex C4

Table 24: Characteristic resistances under shear load in direction of the longitudinal channel axis

Anchor channel		40/22P	50/30P	52/34P	
Steel failure: Connection between channel lips and channel bolt					
Characteristic resistance	$V_{Rk,s,l,x}$ [kN]	Type HSK M16	11,4	19,9	19,9
		Type HSK M20	2)	15,6	15,6
Installation factor	γ_{Inst} [-]		1,0	1,4	1,4
Steel failure: Anchor					
Characteristic resistance	$V_{Rk,s,a,x}$ [kN]		23,6	33,9	60,3
Partial factor	γ_{Ms} ¹⁾		1,80		
Steel failure: Connection between anchor and channel					
Characteristic resistance	$V_{Rk,s,c,x}$		17,2	24,1	31,0
Partial factor	$\gamma_{Ms,ca}$ ¹⁾		1,8		

- 1) In absence of other national regulations
2) No performance assessed

HAZ METAL - Anchor Channel HMPR

Performances

Characteristic resistances under shear load -
Steel failure anchor channel

Annex C5

Table 25: Characteristic resistances under shear load -
Steel failure of channel bolts

Steel failure: Channel Bolts		28/15	38/17	40/22	50/30	72/49		
Characteristic resistance	$V_{Rk,s}$ [kN]	Type HS	M8 8.8	14,6	_2)	_2)	_2)	_2)
			M10 8.8	23,2	23,2	23,2	_2)	_2)
			M12 8.8	33,7	33,7	33,7	33,7	_2)
			M16 8.8	_2)	62,8	62,8	62,8	_2)
			M20 8.8	_2)	_2)	_2)	98,0	98,0
			M24 8.8	_2)	_2)	_2)	_2)	141,2
			M30 8.8	_2)	_2)	_2)	_2)	224,4
			M8 70	15,4	_2)	_2)	_2)	_2)
			M10 70	24,4	24,4	24,4	_2)	_2)
			M12 70	35,2	35,4	35,4	35,4	_2)
			M16 70	_2)	65,9	65,9	65,9	_2)
			M20 70	_2)	_2)	_2)	102,9	102,9
		M24 70	_2)	_2)	_2)	_2)	148,3	
		Type HAZ	M8 8.8	14,6	_2)	_2)	_2)	_2)
			M10 8.8	23,2	23,2	23,2	_2)	_2)
			M12 8.8	33,7	33,7	33,7	33,7	_2)
			M16 8.8	_2)	62,8	62,8	62,8	_2)
		Type HSK				40/22	50/30	
			M16 8.8	_2)	_2)	62,8	62,8	_2)
			M20 8.8	_2)	_2)	_2)	98,0	_2)
Partial factor	γ_{Ms} ¹⁾	8.8	1,25					
		70	1,56					

1) In absence of other regulations

2) No performance assessed

HAZ METAL - Anchor Channel HMPR

Performances

Characteristic resistances under shear load -
Steel failure channel bolts

Annex C6

Table 26: Characteristic resistances under shear load -
Steel failure of channel bolts

Steel failure: Channel Bolts		28/15	38/17	40/22	50/30	72/49		
Characteristic resistance	$M_{Rk,s}^0$ [Nm]	Type HS	M8 8.8	30,0	₃)	₃)	₃)	
			M10 8.8	59,8	59,8	59,8	₃)	₃)
			M12 8.8	104,8	104,8	104,8	104,8	₃)
			M16 8.8	₃)	266,4	266,4	266,4	₃)
			M20 8.8	₃)	₃)	₃)	519,3	519,3
			M24 8.8	₃)	₃)	₃)	₃)	897,6
			M30 8.8	₃)	₃)	₃)	₃)	1799,2
			M8 70	26,2	₃)	₃)	₃)	₃)
			M10 70	52,3	52,3	52,3	₃)	₃)
			M12 70	91,7	91,7	91,7	91,7	₃)
			M16 70	₃)	233,1	233,1	233,1	₃)
			M20 70	₃)	₃)	₃)	454,4	454,4
		M24 70	₃)	₃)	₃)	₃)	785,8	
		Type HAZ	M8 8.8	30,0	₃)	₃)	₃)	₃)
			M10 8.8	59,8	59,8	59,8	₃)	₃)
			M12 8.8	104,8	104,8	104,8	104,8	₃)
			M16 8.8	₃)	266,4	266,4	266,4	₃)
		Type HSK				40/22	50/30	
			M16 8.8	₃)	₃)	266,4	266,4	₃)
			M20 8.8	₃)	₃)	₃)	519,3	₃)
		Partial factor	γ_{Ms} 1)	8.8	1,25			
				70	1,56			

1) In absence of other regulations

2) The characteristic flexure acc. to Table 26 is limited as follows:

$$M_{Rk,s}^0 \leq 0,5 \cdot N_{Rk,s,l}^0 \cdot a$$

$$M_{Rk,s}^0 \leq 0,5 \cdot N_{Rk,s} \cdot a$$

$N_{Rk,s,l}^0$ acc. to Annex C1, Table 20

$N_{Rk,s}$ acc. to Annex C2, Table 21

a acc. to Annex C8, Table 27

3) No performance assessed

HAZ METAL - Anchor Channel HMPR

Performances

Characteristic resistances under shear load -
Steel failure channel bolts

Annex C7

Table 27: Internal lever arm between tension and compression force

Internal lever arm of channel bolts		28/15	38/17	40/22	50/30	72/49	
a [mm]	Type HS	M8 8.8	17,0	- ¹⁾	- ¹⁾	- ¹⁾	- ¹⁾
		M10 8.8	18,3	23,0	17,3	- ¹⁾	- ¹⁾
		M12 8.8	19,7	24,3	18,7	29,7	- ¹⁾
		M16 8.8	- ¹⁾	26,3	20,7	31,7	- ¹⁾
		M20 8.8	- ¹⁾	- ¹⁾	- ¹⁾	34,1	42,7
		M24 8.8	- ¹⁾	- ¹⁾	- ¹⁾	- ¹⁾	45,0
		M30 8.8	- ¹⁾	- ¹⁾	- ¹⁾	- ¹⁾	49,0
		M8 70	18,3	- ¹⁾	- ¹⁾	- ¹⁾	- ¹⁾
		M10 70	20,7	25,3	24,3	- ¹⁾	- ¹⁾
		M12 70	20,3	26,3	26,7	28,0	- ¹⁾
		M16 70	- ¹⁾	23,0	27,7	29,0	- ¹⁾
		M20 70	- ¹⁾	- ¹⁾	- ¹⁾		42,7
	M24 70	- ¹⁾	- ¹⁾	- ¹⁾	- ¹⁾	43,7	
	Type HAZ	M8 8.8	16,9	- ¹⁾	- ¹⁾	- ¹⁾	- ¹⁾
		M10 8.8	18,3	22,8	23,9	- ¹⁾	- ¹⁾
		M12 8.8	20,6	25,2	26,3	30,3	- ¹⁾
		M16 8.8	- ¹⁾	26,2	27,3	31,3	- ¹⁾
	Type HSK				40/22	50/30	
M16 8.8		- ¹⁾	- ¹⁾	20,7	31,7	- ¹⁾	
M20 8.8		- ¹⁾	- ¹⁾	- ¹⁾	34,1	- ¹⁾	

1) No performance assessed

Table 28: Characteristic resistances under combined tension and shear load

Anchor channel		28/15	38/17	40/22	50/30	72/49
Steel failure: Local flexure of channel lips and flexure of channel						
Produkt factor	k_{13}	Values according to EN 1992-4: 2018, Section 7.4.3.1				
Steel failure: Anchor and connection between anchor and channel						
Produkt factor	k_{14}	Values according to EN 1992-4: 2018, Section 7.4.3.1				

HAZ METAL - Anchor Channel HMPR

Performances

Characteristic resistances under shear load lever arm of channel bolts, combined tension and shear load

Annex C8

Table 29: Displacements under tension load

Anchor channel		Steel												Stainless Steel							
		28/15	38/17	40/25	40/26P	49/30	54/33	72/49	40/22	50/30	52/34	40/22P	50/30P	52/34P	28/15	38/17	40/25	40/26P	49/30	54/33	72/49
Tension Load	N [kN]	3,8	6,5	9,5	9,1	17,4	28,3	52,2	12,2	26,1	30,2	9,5	16,0	20,5	2,5	4,5	7,4	10,6	14,1	24,2	31,2
Short-term displacement	δ_{N_0} [mm]	0,3	0,4	0,5	0,5	0,7	0,8	0,8	0,3	0,4	0,5	0,2	0,2	0,3	0,3	0,3	0,4	0,6	0,6	0,8	0,8
Long-term displacement	δ_{N_∞} [mm]	0,6	0,8	1,0	1,0	1,4	1,6	1,6	0,6	0,8	1,0	0,4	0,4	0,6	0,6	0,6	0,8	1,1	1,2	1,6	1,6

Table 30: Displacements under shear load perpendicular to the longitudinal axis of the channel

Anchor channel		Steel												Stainless Steel							
		28/15	38/17	40/25	40/26P	49/30	54/33	72/49	40/22	50/30	52/34	40/22P	50/30P	52/34P	28/15	38/17	40/25	40/26P	49/30	54/33	72/49
Shear Load	V_y [kN]	5,6	8,2	8,8	9,1	10,7	17,5	39,6	5,5	9,7	13,7	5,5	9,7	13,7	3,1	4,5	6,4	10,6	10,4	18,4	38,5
Short-term displacement	$\delta_{V_{y,0}}$ [mm]	0,1	0,2	0,2	0,2	0,2	0,4	0,6	0,2	0,3	0,4	0,5	0,6	0,8	0,2	0,3	0,5	0,8	0,6	0,7	0,8
Long-term displacement	$\delta_{V_{y,\infty}}$ [mm]	0,2	0,3	0,3	0,3	0,3	0,6	0,9	0,3	0,5	0,6	0,8	0,9	1,2	0,3	0,5	0,8	1,2	0,9	1,1	1,2

Table 31: Displacements under shear load in direction of longitudinal axis of the channel

Anchor channel		40/22P	50/30P	52/34P
Shear Load	V_x [kN]	7,1	13,0	13,0
Short-term displacement	$\delta_{V_{x,0}}$ [mm]	0,3	1,4	1,4
Long-term displacement	$\delta_{V_{x,\infty}}$ [mm]	0,5	2,0	2,0

HAZ METAL - Anchor Channel HMPR

Performances

Displacement under tension and shear load

Annex C9

For Design Method I or II for assesment method A1 and A2 according to EOTA TR050, June 2022

Table 33: Combinations of anchor channels and channel bolts for fatigue cyclic tension loading

Anchor channels			Channel bolts			
Profile	d_a [mm]	Material	Type	Thread diameter [mm]	Strength class	Material
40/26P	10	Stainless Steel	HS	M12	70	Stainless Steel
40/22P 40/26P	10	Steel Hot dip galvanized		M12	8.8	Steel Electroplated
50/30P	12	Steel Hot dip galvanized		M16	8.8	Steel Electroplated
52/34P	14	Steel Hot dip galvanized		M16	8.8	Steel Electroplated

Design Method I

Table 34: Characteristic resistances under fatigue tension load with n load cycles without static preload ($N_{Ed}=0$) - Steel failure

Anchor channel	Load cycles n	40/22P	40/26P	50/30P	52/34P	40/26P	
		Steel					Stainless Steel
		$\Delta N_{Rk,s;0;n}$ [kN]					
Characteristic resistances under fatigue tension after n load cycles without static preload	$\leq 10^4$	13,3	8,2	18,1	26,6	12	
	$\leq 10^5$	6,6	2,7	9,4	15,6	4,2	
	$\leq 10^6$	3,1	1,2	5,3	9,1	1,8	
	$\leq 2 \times 10^6$	2,7	1,1	4,8	8,2	1,7	
	$\leq 5 \times 10^6$	2,4	1,1	4,5	7,5	1,6	
	$\leq 10^8$	2,3	1,1	4,2	7,0	1,6	
	$> 10^8$	2,3	1,1	4,2	7,0	1,6	

HAZ METAL - Anchor Channel HMPR

Performances

Characteristic resistances under fatigue cycling tension load according assesment method A1 and A2 - Steel failure

Annex C10

Table 35: Characteristic resistances under fatigue tension load with n load cycles without static preload ($N_{Ed}=0$) - Concrete failure

Anchor channel	Lastzyklen n	40/22P	40/26P	50/30P	52/34P
		$\eta_{k,c,fat} = \eta_{k,p,fat}$ [-]			
Reduction factor for concrete cone / pullout fatigue resistance after n load cycles without static preload ($N_{Ed}=0$) $\Delta N_{Rk,c;0;n} = \eta_{k,c,fat} \cdot N_{Rk,c}$ $\Delta N_{Rk,p;0;n} = \eta_{k,p,fat} \cdot N_{Rk,p}$	$\leq 10^4$	0,736			
	$\leq 10^5$	0,665			
	$\leq 10^6$	0,600			
	$\leq 2 \times 10^6$	0,582			
	$\leq 5 \times 10^6$	0,559			
	$\leq 10^8$	0,500			
	$> 10^8$	0,500			

HAZ METAL - Anchor Channel HMPR

Performances

Characteristic resistances under fatigue cycling tension load according assessment method A1 and A2 - Concrete failure

Annex C11

For Design Method II for assesment method B according to EOTA TR 050, June 2022

Table 36: Characteristic limit resistance under fatigue tension load without static preload ($N_{Ed}=0$)
-Steel failure

Anchor channel	40/22P	40/26P	50/30P	52/34P	40/26P
	Steel				Stainless Steel
	$\Delta N_{Rk,s;0;\infty}$ [kN]				
Characteristic fatigue limit resistance ($n \rightarrow \infty$) for steel failure without static preload ($N_{Ed} = 0$)	2,3	1,1	4,2	7,0	1,6

Table 37: Characteristic limit resistance under fatigue tension load without static preload ($N_{Ed}=0$)
-Concrete failure

Anchor channel	40/22P	40/26P	50/30P	52/34P
	$\eta_{k,c,fat} = \eta_{k,p,fat}$ [-]			
Characteristic fatigue limit resistance ($n \rightarrow \infty$) for concrete failure without static preload ($N_{Ed} = 0$) $\Delta N_{Rk,c;0;\infty} = \eta_{k,c,fat} \cdot N_{Rk,c}$ $\Delta N_{Rk,p;0;\infty} = \eta_{k,p,fat} \cdot N_{Rk,p}$	0,5			

In absence of other national regulations, the following partial factors are recommended for design methode I and II:

$$\gamma_{Ms,fat} = 1,35 \text{ (Steel)}$$

$$\gamma_{Mc,fat} = \gamma_{Mp,fat} = 1,5 \text{ (Concrete)}$$

HAZ METAL - Anchor Channel HMPR

Performances

Characteristic resistances under fatigue cycling tension load according assesment method B

Annex C12

Table 32: Characteristic resistances under tension and shear load with fire exposure

Anchor channel		28/15	38/17	40/25 40/26P 40/22 40/22P	49/30 50/30 50/30P 52/34 52/34P 54/33	72/49		
Type HS	Channel bolt thread	M12	M16	M16	M16	M16		
Steel failure: Anchor, connection between anchor and channel, local flexure of channel lips, channel bolt								
Characteristic resistance	R30	$N_{Rk,s,fi}$ = $V_{Rk,s,y,fi}$	[kN]	0,9	1,8	1,8	5,7	5,7
	R60			0,7	1,5	1,5	4,2	4,2
	R90			0,5	1,2	1,2	2,6	2,6
	R120			0,4	1,1	1,1	1,8	1,8
Partial factor		$\gamma_{Ms,fi}^{1)}$	[-]	1,0				
Minimum axis distance	R30	a	[mm]	35	35	35	35	35
	R60			35	35	35	35	35
	R90			45	45	45	45	45
	R120			60	60	60	60	60

1) In absence of other regulations

Fig. 1: One-sided fire exposure

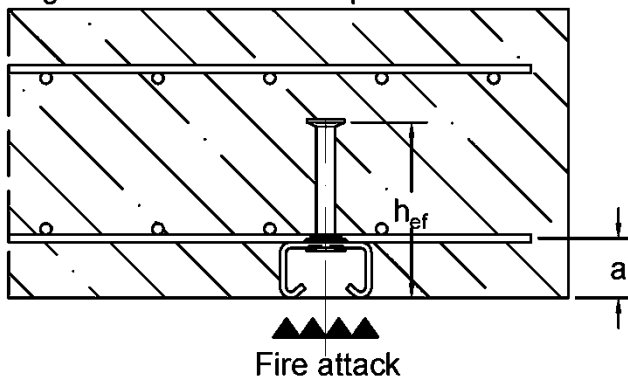
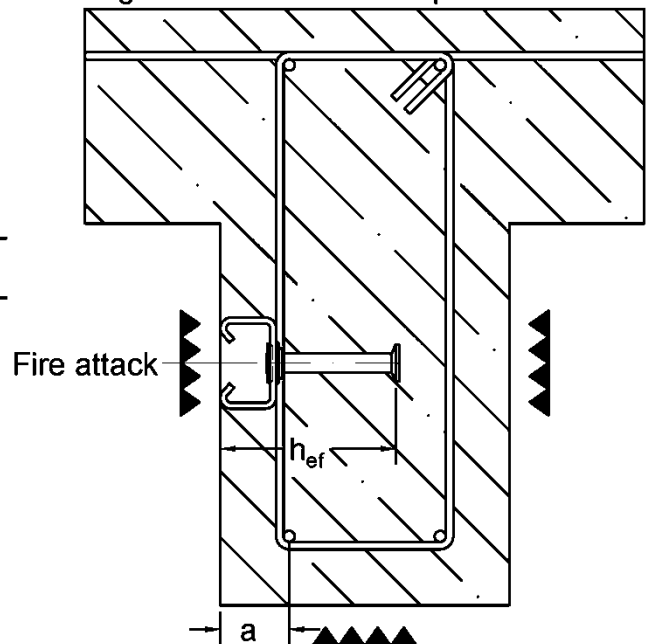

Fig. 2: Multi-sided fire exposure



HAZ METAL - Anchor Channel HMPR

Performances

Characteristic resistances under tension and shear load perpendicular to the longitudinal axis of the channel under fire exposure

Annex C13